

KTIR - Technical Specifications

| Klimaïre Model Number | | | KTIR09-H2 | KTIR12-H2 | KTIR18-H2 | KTIR24-H2 | KTIR036-H2G1 | KTIR048-H2G1 |
|--------------------------------|------------------------------|-------|-------------------|-------------------|-------------------|------------------|----------------|-----------------|
| Power supply | V-ph-Hz | | 208-230~1-60 | 208-230~1-60 | 208-230~1-60 | 208-230~1-60 | 208-230~1-60 | 208-230~1-60 |
| Capacity | Cooling | Btu/h | 9000 | 12000 | 18000 | 24000 | 36000 | 48000 |
| | Heating @ 47°F | Btu/h | 10000 | 12000 | 18000 | 24400 | 25200 | 35000 |
| | Power input | W | 45 | 45 | 45 | 58 | 141 | 232 |
| Indoor fan motor | RLA | A | 0,9 | 1,0 | 1,5 | 2 | 1,5 | 1,6 |
| | Speed (Hi) | rpm | 600/520/460 | 680/580/500 | 730/630/570 | 600/520/450 | 720/630/560 | 950/900/800/700 |
| Indoor air flow (Hi/Mid/Lo) | | cfm | 374/301/257 | 379/309/261 | 560/483/415 | 700/636/573 | 1095/958/809 | 1177/1030/853 |
| Indoor noise level (Hi/Mid/Lo) | | dB(A) | 41/37/33 | 43/39/36 | 44/39/36 | 51/47/43 | 55/52/49 | 55/52/49 |
| Indoor unit | Dimension (WxDxH) (body) | in | 22.44x22.44x10.24 | 22.44x22.44x10.24 | 22.44x22.44x10.24 | 33.07x33.07x8.07 | 33.1x33.1x9.7 | 33.1x33.1x11.3 |
| | Packing (WxDxH) (body) | in | 25.79x25.79x11.42 | 25.79x25.79x11.42 | 25.79x25.79x11.42 | 35.43x35.43x8.54 | 35.4x35.4x10.1 | 35.4x35.4x11.5 |
| | Dimension (WxDxH) (panel) | in | 25.47x25.47x1.97 | 25.47x25.47x1.97 | 25.47x25.47x1.97 | 37.4x37.4x2.17 | 37.4x37.4x2.2 | 37.4x37.4x2.2 |
| | Packing (WxDxH) (panel) | in | 28.15x28.15x4.84 | 28.15x28.15x4.84 | 28.15x28.15x4.84 | 40.75x40.75x3.54 | 40.8x40.8x3.5 | 40.8x40.8x3.5 |
| | Net/Gross weight (body) | lb | 31.97/38.14 | 35.27/41 | 35.49/41.23 | 46.3/54.23 | 58.2/66.14 | 63.27/72.53 |
| | Net/Gross weight (panel) | lb | 5.51/9.92 | 5.51/9.92 | 5.51/9.92 | 11.02/17.64 | 11.02/17.64 | 11.02/17.64 |
| Design pressure | | psig | 540/300 PSIG | 540/300 PSIG | 550/340 PSIG | 550/340 PSIG | 550/340 PSIG | 550/340 PSIG |
| Drainage water pipe diameter | | in | OD Ø1" | OD Ø1" | OD Ø1" | ODØ 1" / 1/4 | '1 - 9/32 | '1 - 9/32 |
| Refrigerant piping | Liquid side/Gas side (Flare) | in | 1/4" / 3/8" | 1/4" / 1/2" | 1/4" / 1/2" | 3/8" / 5/8" | 3/8" / 5/8" | 3/8" / 5/8" |
| Control type | | | Remote control | Remote control | Remote control | Remote control | Remote control | Remote control |
| Room temperature | Cooling | °F | 62~90 | 62~90 | 62~90 | 62~90 | 62~90 | 62~90 |
| | Heating | °F | 32~86 | 32~86 | 32~86 | 32~86 | 32~86 | 32~86 |
| Operation temperature | | °F | 62~86 | 62~86 | 62~86 | 62~86 | 62~86 | 62~86 |

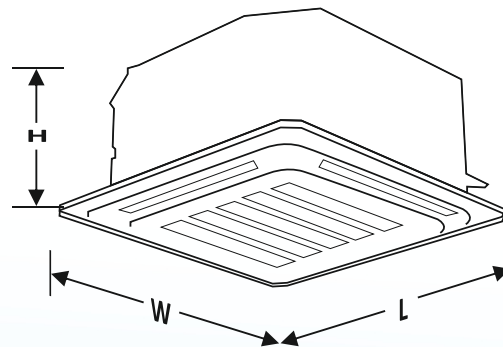

Continued product improvement is our goal at Klimaïre Products, Inc. Hence, specifications and data listed herein are subject to change without notice and without obligation on our part. Always comply with local, state, and national electrical codes.

1. - The above design and specifications are subject to change without prior notice for product improvement.
2. - The values given in the table for the noise level reflect the levels in anechoic chamber.