

Service Instructions

**ANX, SSX, ASX, GSX, DSX
Condensing Units,
ANZ, SSZ, ASZ, GSZ, DSZ, VSX, VSZ Split System Heat Pumps
with R-410A Refrigerant
Blowers, Coils, & Accessories**

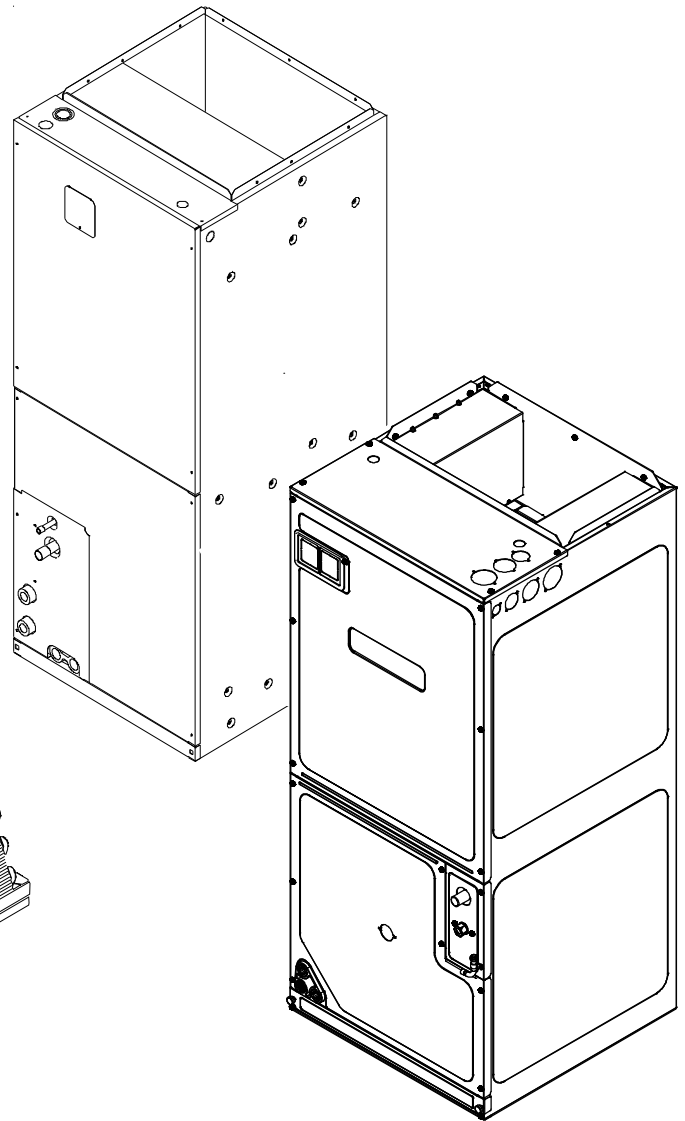
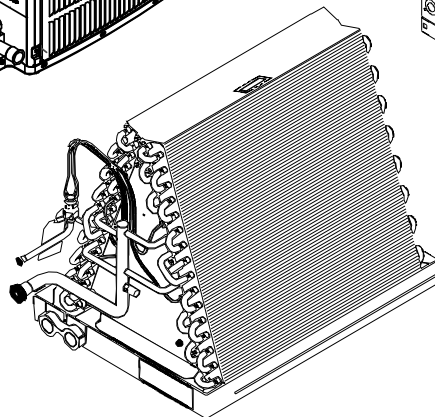
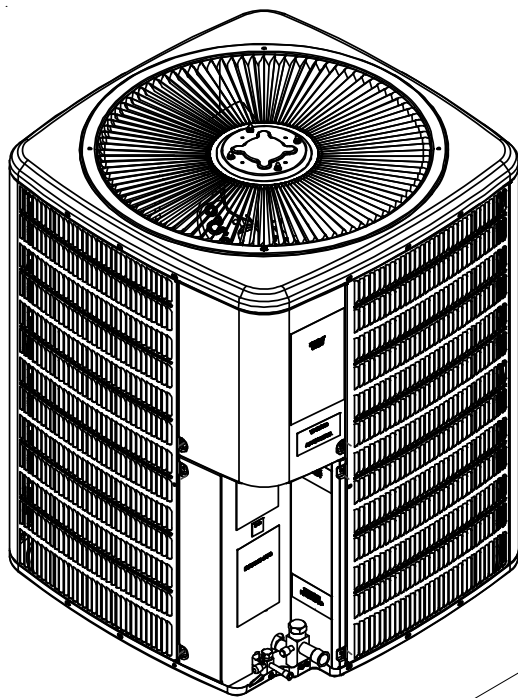

This manual is to be used by qualified, professionally trained HVAC technicians only. The manufacturer does not assume any responsibility for property damage or personal injury due to improper service procedures or services performed by an unqualified person.

RS6200006r74
October 2016

Table of Contents

IMPORTANT INFORMATION	2	SPLIT SYSTEM HEAT PUMPS	12
PRODUCT IDENTIFICATION - MODEL TREES	4	AIR HANDLERS	33
COILS	6	COILS	39
BLOWERS	7	ACCESSORIES - LIGHT COMMERCIAL	41
AIR HANDLERS	8	MODELS TO KITS MATCHUP	42
LIGHT COMMERCIAL	10	ASSOCIATED KITS	51
PRODUCT IDENTIFICATION - CHARTS	11	PRODUCT DESIGN	63
LIGHT COMMERCIAL	11	SYSTEM OPERATION	66
		TROUBLESHOOTING CHART	70

IMPORTANT INFORMATION

Pride and workmanship go into every product to provide our customers with quality products. It is possible, however, that during its lifetime a product may require service. Products should be serviced only by a qualified service technician who is familiar with the safety procedures required in the repair and who is equipped with the proper tools, parts, testing instruments and the appropriate service manual. **REVIEW ALL SERVICE INFORMATION IN THE APPROPRIATE SERVICE MANUAL BEFORE BEGINNING REPAIRS.**

IMPORTANT NOTICES FOR CONSUMERS AND SERVICERS

RECOGNIZE SAFETY SYMBOLS, WORDS AND LABELS

 **WARNING**

THIS UNIT SHOULD NOT BE CONNECTED TO, OR USED IN CONJUNCTION WITH, ANY DEVICES THAT ARE NOT DESIGN CERTIFIED FOR USE WITH THIS UNIT OR HAVE NOT BEEN TESTED AND APPROVED BY THE MANUFACTURER. SERIOUS PROPERTY DAMAGE OR PERSONAL INJURY, REDUCED UNIT PERFORMANCE AND/OR HAZARDOUS CONDITIONS MAY RESULT FROM THE USE OF DEVICES THAT HAVE NOT BEEN APPROVED OR CERTIFIED BY THE MANUFACTURER.

 **WARNING**

HIGH VOLTAGE
DISCONNECT ALL POWER BEFORE SERVICING OR INSTALLING UNIT. MULTIPLE POWER SOURCES MAY BE PRESENT. FAILURE TO DO SO MAY CAUSE PROPERTY DAMAGE, PERSONAL INJURY OR DEATH.



 **WARNING**

TO PREVENT THE RISK OF PROPERTY DAMAGE, PERSONAL INJURY, OR DEATH, DO NOT STORE COMBUSTIBLE MATERIALS OR USE GASOLINE OR OTHER FLAMMABLE LIQUIDS OR VAPORS IN THE VICINITY OF THIS APPLIANCE.

 **WARNING**

ONLY PERSONNEL THAT HAVE BEEN TRAINED TO INSTALL, ADJUST, SERVICE OR REPAIR (HEREINAFTER, "SERVICE") THE EQUIPMENT SPECIFIED IN THIS MANUAL SHOULD SERVICE THE EQUIPMENT. THE MANUFACTURER WILL NOT BE RESPONSIBLE FOR ANY INJURY OR PROPERTY DAMAGE ARISING FROM IMPROPER SERVICE OR SERVICE PROCEDURES. IF YOU SERVICE THIS UNIT, YOU ASSUME RESPONSIBILITY FOR ANY INJURY OR PROPERTY DAMAGE WHICH MAY RESULT. IN ADDITION, IN JURISDICTIONS THAT REQUIRE ONE OR MORE LICENSES TO SERVICE THE EQUIPMENT SPECIFIED IN THIS MANUAL, ONLY LICENSED PERSONNEL SHOULD SERVICE THE EQUIPMENT. IMPROPER INSTALLATION, ADJUSTMENT, SERVICING OR REPAIR OF THE EQUIPMENT SPECIFIED IN THIS MANUAL, OR ATTEMPTING TO INSTALL, ADJUST, SERVICE OR REPAIR THE EQUIPMENT SPECIFIED IN THIS MANUAL WITHOUT PROPER TRAINING MAY RESULT IN PRODUCT DAMAGE, PROPERTY DAMAGE, PERSONAL INJURY OR DEATH.

To locate an authorized servicer, please consult your telephone book or the dealer from whom you purchased this product. For further assistance, please contact:

CONSUMER INFORMATION LINE

GOODMAN® BRAND PRODUCTS
TOLL FREE

1-877-254-4729 (U.S. only)

email us at: customerservice@goodmanmfg.com

fax us at: **(713) 856-1821**

(Not a technical assistance line for dealers.)

AMANA® BRAND PRODUCTS
TOLL FREE

1-877-254-4729 (U.S. only)

email us at: customerservice@goodmanmfg.com

fax us at: **(713) 856-1821**

(Not a technical assistance line for dealers.)

Outside the U.S., call **1-713-861-2500**.

(Not a technical assistance line for dealers.) Your telephone company will bill you for the call.

Amana is a registered trademark of Maytag Corporation or its related companies and is used under license. All rights reserved.

IMPORTANT INFORMATION

SAFE REFRIGERANT HANDLING

While these items will not cover every conceivable situation, they should serve as a useful guide.

WARNING

REFRIGERANTS ARE HEAVIER THAN AIR. THEY CAN "PUSH OUT" THE OXYGEN IN YOUR LUNGS OR IN ANY ENCLOSED SPACE. TO AVOID POSSIBLE DIFFICULTY IN BREATHING OR DEATH:

- NEVER PURGE REFRIGERANT INTO AN ENCLOSED ROOM OR SPACE. BY LAW, ALL REFRIGERANTS MUST BE RECLAIMED.
- IF AN INDOOR LEAK IS SUSPECTED, THOROUGHLY VENTILATE THE AREA BEFORE BEGINNING WORK.
- LIQUID REFRIGERANT CAN BE VERY COLD. TO AVOID POSSIBLE FROSTBITE OR BLINDNESS, AVOID CONTACT WITH REFRIGERANT AND WEAR GLOVES AND GOGGLES. IF LIQUID REFRIGERANT DOES CONTACT YOUR SKIN OR EYES, SEEK MEDICAL HELP IMMEDIATELY.
- ALWAYS FOLLOW EPA REGULATIONS. NEVER BURN REFRIGERANT, AS POISONOUS GAS WILL BE PRODUCED.

WARNING

TO AVOID POSSIBLE EXPLOSION:

- NEVER APPLY FLAME OR STEAM TO A REFRIGERANT CYLINDER. IF YOU MUST HEAT A CYLINDER FOR FASTER CHARGING, PARTIALLY IMMERSE IT IN WARM WATER.
- NEVER FILL A CYLINDER MORE THAN 80% FULL OF LIQUID REFRIGERANT.
- NEVER ADD ANYTHING OTHER THAN R-22 TO AN R-22 CYLINDER OR R-410A TO AN R-410A CYLINDER. THE SERVICE EQUIPMENT USED MUST BE LISTED OR CERTIFIED FOR THE TYPE OF REFRIGERANT USED.
- STORE CYLINDERS IN A COOL, DRY PLACE. NEVER USE A CYLINDER AS A PLATFORM OR A ROLLER.

WARNING

TO AVOID POSSIBLE EXPLOSION, USE ONLY RETURNABLE (NOT DISPOSABLE) SERVICE CYLINDERS WHEN REMOVING REFRIGERANT FROM A SYSTEM.

- ENSURE THE CYLINDER IS FREE OF DAMAGE WHICH COULD LEAD TO A LEAK OR EXPLOSION.
- ENSURE THE HYDROSTATIC TEST DATE DOES NOT EXCEED 5 YEARS.
- ENSURE THE PRESSURE RATING MEETS OR EXCEEDS 400 PSIG.

WHEN IN DOUBT, DO NOT USE CYLINDER.

WARNING

THE UNITED STATES ENVIRONMENTAL PROTECTION AGENCY ("EPA") HAS ISSUED VARIOUS REGULATIONS REGARDING THE INTRODUCTION AND DISPOSAL OF REFRIGERANTS INTRODUCED INTO THIS UNIT. FAILURE TO FOLLOW THESE REGULATIONS MAY HARM THE ENVIRONMENT AND CAN LEAD TO THE IMPOSITION OF SUBSTANTIAL FINES. THESE REGULATIONS MAY VARY BY JURISDICTION. SHOULD QUESTIONS ARISE, CONTACT YOUR LOCAL EPA OFFICE.

WARNING

TO AVOID POSSIBLE INJURY, EXPLOSION OR DEATH, PRACTICE SAFE HANDLING OF REFRIGERANTS.

WARNING

SYSTEM CONTAMINANTS, IMPROPER SERVICE PROCEDURE AND/OR PHYSICAL ABUSE AFFECTING HERMETIC COMPRESSOR ELECTRICAL TERMINALS MAY CAUSE DANGEROUS SYSTEM VENTING.

The successful development of hermetically sealed refrigeration compressors has completely sealed the compressor's moving parts and electric motor inside a common housing, minimizing refrigerant leaks and the hazards sometimes associated with moving belts, pulleys or couplings.

Fundamental to the design of hermetic compressors is a method whereby electrical current is transmitted to the compressor motor through terminal conductors which pass through the compressor housing wall. These terminals are sealed in a dielectric material which insulates them from the housing and maintains the pressure tight integrity of the hermetic compressor. The terminals and their dielectric embedment are strongly constructed, but are vulnerable to careless compressor installation or maintenance procedures and equally vulnerable to internal electrical short circuits caused by excessive system contaminants.

In either of these instances, an electrical short between the terminal and the compressor housing may result in the loss of integrity between the terminal and its dielectric embedment. This loss may cause the terminals to be expelled, thereby venting the vaporous and liquid contents of the compressor housing and system.

A venting compressor terminal normally presents no danger to anyone, providing the terminal protective cover is properly in place.

If, however, the terminal protective cover is not properly in place, a venting terminal may discharge a combination of

- (a) hot lubricating oil and refrigerant
- (b) flammable mixture (if system is contaminated with air)

in a stream of spray which may be dangerous to anyone in the vicinity. Death or serious bodily injury could occur.

Under no circumstances is a hermetic compressor to be electrically energized and/or operated without having the terminal protective cover properly in place.

See Service Section S-17 for proper servicing.

PRODUCT IDENTIFICATION

A N Z 13 018 1 AA

1 2 3 4,5 6,7,8 9 10,11

Brand

A - Amana® brand

Type

N Deluxe Split System

Type

X: Condenser R-410A

Z: Heat Pump R-410A

SEER

11 - 11 SEER

13 - 13 SEER

14 - 14 SEER

16 - 16 SEER

Engineering

Major/Minor Revisions

Voltage

1 - 208/230V Single-Phase 60 Hz

2 - 220/240V Single-Phase 50 Hz

3 - 208/230V Three-Phase 60 Hz

4 - 460V Three-Phase 60 Hz

5 - 380/415V Three-Phase 50 Hz

Nominal Capacity

18 = 1-1/2 Tons

24 = 2 Tons

30 = 2-1/2 Tons

36 = 3 Tons

42 = 3-1/2 Tons

48 = 4 Tons

59 = 5 Tons

60 = 5 Tons

61 = 5 Tons

PRODUCT IDENTIFICATION

S S Z 14 036 1 AA

1 2 3 4,5 6,7,8 9 10,11

Brand

- G Goodman® brand
(Standard Feature Set)
- S Goodman® brand
(High Feature Set)
- A Amana® brand
Deluxe
- D Goodman® brand
Deluxe
- V Value Line

Engineering

Major/Minor Revisions

Type

- S Split System

Voltage

- 1 - 208/230V Single-Phase 60 Hz
- 2 - 220/240V Single-Phase 50 Hz
- 3 - 208/230V Three-Phase 60 Hz
- 4 - 460V Three-Phase 60 Hz
- 5 - 380/415V Three-Phase 50 Hz

Type

- X: Condenser R-410A
- Z: Heat Pump R-410A

SEER

- 13 - 13 SEER
- 14 - 14 SEER
- 16 - 16 SEER
- 18 - 18 SEER

- 018 = 1-1/2 Tons
- 024 = 2 Tons
- 030 = 2-1/2 Tons
- 036 = 3 Tons
- 038 = 3 Tons

- 042 = 3-1/2 Tons
- 048 = 4 Tons
- 059 = 5 Tons
- 060 = 5 Tons

PRODUCT IDENTIFICATION

C A P F 1824 A 6 AA

1 2 3 4 5,6,7,8 9 10 11,12

Brand Indoor Coil **Engineering*** Major/Minor Revisions

Unit Application A Upflow/Downflow Coil 2 = R-22
H Horizontal A-Coil 4 = R-410A
S Horizontal Slab Coil 6 = R-410A or R-22
T Coated Coils

Cabinet Finish U Unpainted **Nominal Capacity @ 13 SEER**
P Painted 1824 = 1-1/2 - 2 Tons
N Unpainted Case 3030 = 2-1/2 Tons
3131 = 2-1/2 Tons
3636 = 3 Tons
3642 = 3 - 3-1/2 Tons
3743 = 3 - 3-1/2 Tons
4860 = 4 - 5 Tons
4961 = 4 - 5 Tons

Expansion Device F Flowrator
T Factory-Installed Non-Adjustable Expansion Valve

Refrigerant Charge

Nominal Width for Gas Furnace
A = Fits 14" Furnace Cabinet
B = Fits 17-1/2" Furnace Cabinet
C = Fits 21" Furnace Cabinet
D = Fits 24-1/2" Furnace Cabinet
N = Does Not Apply (Horizontal Slab Coils)

PRODUCT IDENTIFICATION

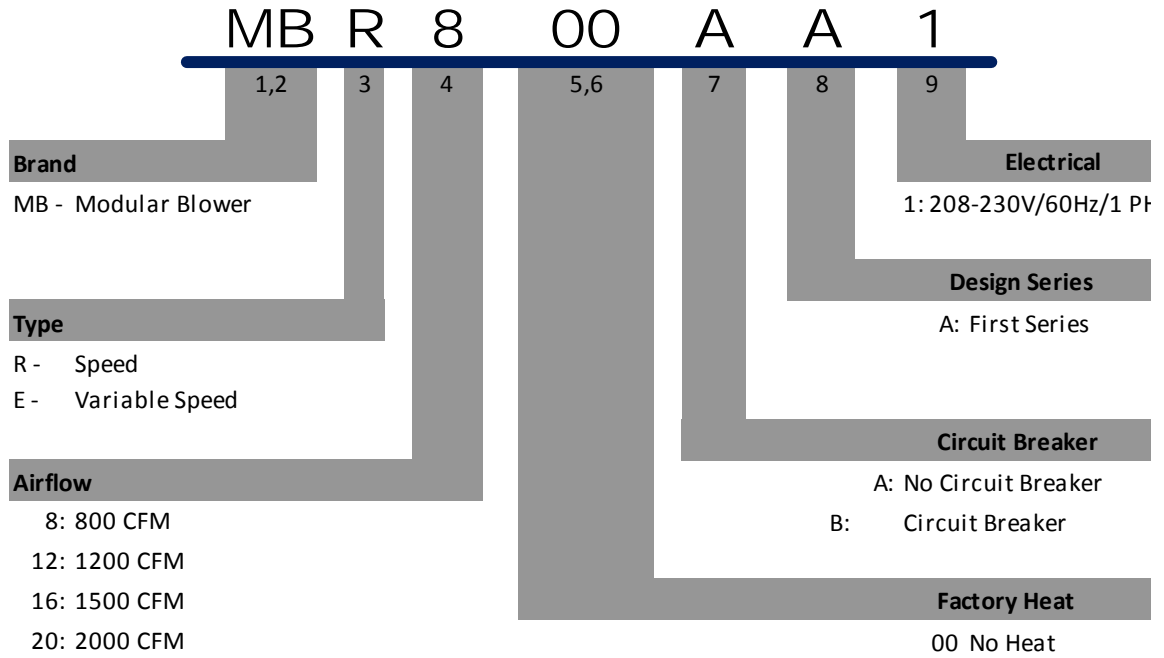

PRODUCT IDENTIFICATION

A W U F 3642 1 6 AA

	1	2	3	4	5,6,7,8	9	10	11,12	
Brand									Engineering*
A	Airhandler								Major/Minor Revisions
Unit Application									Refrigerant Charge
C	Ceiling Mount PSC Motor								4 = R-410a
D	Downflow PSC Motor								
E	Multi Position Variable Speed								Electrical
R	Multi Position PSC Motor								1 208/240V, 1 Phase, 60 Hz
S	Multi Position EEM Motor								
T	Coated Coils								
W	Wall Mount PSC/EEM Motor								Nominal Capacity
Cabinet Finish									@ 13 SEER Dedicated Application
U	Unpainted								3636 = 3 Ton
P	Painted								Multi-Position & Downflow Application
N	Uncased								1830 = 1-1/2 - 3-1/2 Tons
Expansion Device									3137 = 3 Tons
F	Flowrator								3642 = 3 - 3-1/2Tons
T	Expansion Valve								Multi-Position & Downflow Application @10 SEER
									1729 = 3 Ton
									Ceing Mount & Wall Mount Applications (Nominal Cooling Capacity/Electric Heat kW)
									1803 = 1-1/2 Tons Cooling/3 kW Electric Heat
									1805 = 1-1/2 Tons Cooling/5 kW Electric Heat
									2405 = 2 Tons Cooling/5 kW Electric Heat
									3608 = 3 Tons Cooling/8 kW Electric Heat
									3105 = 1-1/2 - 2-1/2 Tons Cooling/5 kW Electric Heat
									3210 = 2 - 2-1/2 Tons Cooling/5 kW Electric Heat
									3705 = 3 Tons Cooling/5 kW Electric Heat
									3708 = 3 Tons Cooling/8 kW Electric Heat
									3710 = 3 Tons Cooling/10 kW Electric Heat

*An "F" in the model number denotes a
Factory Installed Float Switch is present.*

All Airhandlers use **DIRECT DRIVE MOTORS**. Power supply is AC 208-240v, 60 hz, 1 phase.

PRODUCT IDENTIFICATION

A R U F 18 B 1 4 AA



	1	2	3	4	5,6	7	8	9	10,11																																							
Brand	A Single-Piece Airhandler										Engineering*																																					
																	Major/Minor Revisions																															
Unit Application	C Ceiling Mount PSC Motor R Multi Position PSC Motor S Multi Position EEM Motor W Wall Mount PSC/EEM Motor																Refrigerant Charge																															
																	4 = R-410a																															
																							Electrical																									
																													1 208/240V, 1 Phase, 60 Hz																			
Cabinet Finish	U Unpainted P Painted N Uncased																												Cabinet Width																			
																													B = 17-1/2" Wide																			
																													C = 21" Wide																			
																													D = 24-1/2" Wide																			
Expansion Device	F Flowrator T Expansion Valve																												Nominal Capacity @ 13SEER																			
																													18 = 1-1/2 Tons	42 = 3-1/2 Tons																		
																													24 = 2 Tons	47 = 3-1/2 Tons																		
																													25 = 2 Tons	48 = 4 Tons																		
																																			29 = 2-1/2 - 3 Tons	49 = 4 Tons												
																																									30 = 2-1/2 Tons	59 = 5 Tons						
																																															36 = 3 Tons	60 = 5 Tons

Airhandlers use DIRECT DRIVE MOTORS. Power supply is AC 208-230v, 60 hz, 1 phase.

PRODUCT IDENTIFICATION

LIGHT COMMERCIAL

G S X 11 090 1 AA

1 2 3 4,5 6,7,8 9 10,11

Brand

G - Goodman brand
A - Amana brand

Engineering

Major/Minor Revisions

Type

S Split System

Voltage

- 1 - 208/230V Single-Phase 60 Hz
- 2 - 220/240V Single-Phase 50 Hz
- 3 - 208/230V Three-Phase 60 Hz
- 4 - 460V Three-Phase 60 Hz
- 5 - 380/415V Three-Phase 50 Hz

Type

X: Condenser R-410A
Z: Heat Pump R-410A

SEER

- 11 - 11 SEER
- 13 - 13 SEER
- 14 - 14 SEER
- 16 - 16 SEER

Nominal Capacity

- 036 - 3 Tons
- 048 - 4 Tons
- 060 - 5 Tons
- 090 - 7-1/2 Tons
- 120 - 10 Tons

A R 090 AA

1 2 3,4,5 6,7

Brand

A Single Piece
Air Handler

Engineering

Major/Minor Revisions

Unit Application

R Multi Position
PSC Motor

Nominal Capacity

- 090 7-1/2 Tons
- 120 10 Tons

For use with GSX/GSZ11 Light Commercial models only.

PRODUCT IDENTIFICATION

LIGHT COMMERCIAL

GSX11 LIGHT COMMERCIAL GOODMAN® BRAND SPLIT X-R410A CONDENSERS 11 SEER	
Model/Rev	Description
GSX11090*AA GSX11120*AA	Introduction of Goodman Light Commercial 11 SEER, R-410A Condensers.
GSX111203AB GSX110903AB GSX111204AB GSX110904AB	208-230V and 460V 3 Phase condensing units with new ball valve/brackets, suction tube/assembly and panel w/offset.

GSZ11 LIGHT COMMERCIAL GOODMAN SPLIT Z-R410A HEAT PUMP 11 SEER	
Model/Rev	Description
GSZ11090*AA GSZ11120*AA	Introduction of Goodman Light Commercial 11 SEER, R-410A Heat Pumps.
GSZ110903AB GSZ111203AB GSZ110904AB GSZ111204AB	208-230V and 460V 3 Phase R410A heat pump units with new ball valve/brackets, suction tube/assembly and panel w/offset.

AR LIGHT COMMERCIAL A SINGLE PIECE R-MULTI-POSITION PSC MOTOR	
Model/Rev	Description
AR0904A AR1204A	Introduction of new 7.5 & 10 Ton Air Handler Models, for use with GSX11 and GSZ11 Light Commercial Models.

PRODUCT IDENTIFICATION

Split System Heat Pumps

ASZ13 AMANA® BRAND SPLIT Z-R410A HEAT PUMP 13 SEER	
Model/Rev	Description
ASZ130**1AA	Initial release of Amana® Brand 13 SEER Heat Pump R410A.
ASZ130**1AB	Introduces new revisions with improved circuiting for effective defrost.
ASZ130[18, 36-60]1AB ASZ130[24-30]1AC	Introduces models containing crankcase heater, CCH switch and upgraded defrost control.
ASZ130[18, 36-60]1AC ASZ130[24-30]1AD	Relocation of low pressure switch from liquid line to suction line as a compressor safeguard to prevent low pressure from entering.
ASZ130[18, 36-60]1AD ASZ130[24-30]1AE	Initial release of models using single speed PSC motors; removal of low ambient temperature switch.
ASZ130241BA	Release of 2 Ton models, converting from 3/8" to 5mm condenser coils
ASZ130181AF ASZ130[24-30]1AG	Current reversing valve change from Dunan to new SanHua reversing valve
ASZ130481AF	Current Ranco reversing valve 0151M00020 replaced by SanHua 0151R00070 reversing valve
ASZ130361AG ASZ130421AH	Change from copper wound motor to aluminum wound motor.

PRODUCT IDENTIFICATION

Split System Heat Pumps

ASZ14 AMANA® BRAND SPLIT Z-R410A HEAT PUMP 14 SEER	
Model/Rev	Description
ASZ140**1AA	Initial release of Amana® Brand 14 SEER Heat Pump R410A with sound blankets and Coresense control.
ASZ140**1AB	Screw locations moved in the top panel, base pans, louvers, and control box covers.
ASZ140**1AC	Horizontal style louvers.
ASZ140[18, 42-48]1AD ASZ140[24-36, 60]1AE	New steel muffler, and suction tubes w/shock loop.
ASZ140361AF ASZ140421AD ASZ140[48-60]1AE	TXV & compensator replaced with flowrator & accumulator.
ASZ140[18, 30,36]1AF ASZ140241AG ASZ14[42, 48, 60]1AE	Sanhua (RANCO) reversing valves.
ASZ140241AF	Smaller B1227315 reversing valve.
ASZ140[18,30,36]1AG ASZ140241AH ASZC160[42,48,60]1AF	Introduction of heat pumps with accumulators, crankcase heaters, and upgraded defrost control.
ASZ140361BA	Chassis size reduction from large to medium.
ASZ140[18, 30]1AH ASZ140241AJ ASZ140[42-60]1AG	Relocation of low pressure switch from liquid line to suction line as a compressor safeguard to prevent low pressure from entering.
ASZ140[18, 30]1AJ ASZ140241AK ASZ140[42-60]1AH ASZ140361BB	2 speed PSC motors replaced with single speed PSC motors.
ASZ140181AL ASZ140241AM ASZ140301AL ASZ140361BC ASZ140381AB ASZ140[42-60]1AK	Revision made for design improvement.
ASZ140381AA	35" chassis with 6-channel flowrator and ZP29K5 compressor.
ASZ140[18-30]1BA	Updated ratings and agency information.
ASZ140[18-60]1KA	Introduction of ready 15, 14 SEER heat pumps to meet the 2015 energy efficiency requirement.
ASZ140[421,491,]KB	Motor change on 3 & 3.5T 14 SEER & 2 & 2.5T 16 SEER. Increase blade gap.
ASZ140181KC	Change from copper wound motor to aluminum wound motor.
ASZ140[241, 301, 361, 481, 601]KB ASZ140[421, 491] KC	Refrigerant Charge Reduction
ASZ140181KD	Refrigerant Charge Reduction
ASZ140[241,301,361,]KC	Equivalent motor with Aluminum Windings replacing Copper Windings.

PRODUCT IDENTIFICATION

Split System Heat Pumps

ASZ16 AMANA® BRAND SPLITS Z-R410A HEAT PUMP 16 SEER	
Model/Rev	Description
ASZ160**1AA	Initial release of Amana® Brand 16 SEER Heat Pump R410A.
ASZ160**1AB	Introduces models with screw locations moved in the top panel, base pans, louvers, and control box covers.
ASZ160**1AC	Horizontal style louvers.
ASZ160**1AD	Muffler and standardized TXV, Compensator using the ASZ18 Seer weldment.
ASZ160241AD ASZ160[36-60]AE	Adds new steel muffler, and suction tubes w/shock loop.
ASZ160[24, 36]1AF ASZ160[48, 60]1AF	Sanhua (RANCO) reversing valves.
ASZ160[24,36,48,60]1KA	Initial release of Amana® Brand 16 SEER Heat Pump models
ASZ160[18-48]1LA	Initial release of Amana® Brand 16 SEER Heat Pump models with 9.6+ HSPF
ASZ160601LA	Initial release of Amana® Brand 5 Ton 16 SEER, 13 eer Heat Pump models.
ASZ160[241,301]LB	Motor change on 3 & 3.5T 14 SEER & 2 & 2.5T 16 SEER. Increase blade gap.
ASZ160181LB	16SEER 1.5T Heat Pumps, Remove Hard Start Kit
ASZ160181LC	Change from copper wound motor to aluminum wound motor.

ASZ18 AMANA® BRAND SPLIT Z-R410A HEAT PUMP 18 SEER	
Model/Rev	Description
ASZ180**1AB	Initial release of Amana® Brand 18 SEER Heat Pump R410A.
ASZ180[36, 48, 60]1AC	Sanhua (RANCO) reversing valves.

PRODUCT IDENTIFICATION

Split System Heat Pumps

ANZ13 AMANA® BRAND SPLIT SYSTEM N-BASE Z-R410A HEAT PUMP 13 SEER	
Model/Rev	Description
ANZ130[18-60]1AA	Initial release of Amana® Brand Split System Base Heat Pump, 13 Seer R-410A units.
ANZ130[18/24/30]1AB	Reversing valve change from Dunan to new SanHua reversing valve
ANZ130481AB	Ranco 0151M00020 reversing valve changed to new SanHua 0151R00070 reversing valve
ANZ130241AC	Create new Motor & Replace 0131M00294 with 0131M00800

ANZ14 AMANA® BRAND SPLIT SYSTEM N-BASE Z-R410A HEAT PUMP 14 SEER	
Model/Rev	Description
ANZ140(18-60)1AA	Introduction of ready 15, 14 SEER heat pumps to meet the 2015 energy efficiency requirement.
ANZ140(24-30)1AB	Energy guide update.
ANZ140181AB	Minor revisions on OD units ZP14K6 compressors without hard start kit. 14S 1.5T HPs ONLY.
ANZ140421AB ANZ140491AB	Motor change on 3 & 3.5T 14 SEER & 2 & 2.5T 16 SEER. Increase blade gap.
ANZ140[181, 301]AC ANZ140361AB	Change from copper wound motor to aluminum wound motor.
ANZ140[421, 491]AC ANZ140[481, 601]AB	Refrigerant Charge Reduction
ANZ140[181,301]AD ANZ140361AC	Refrigerant Charge Reduction
ANZ140241AD	Equivalent motor with Aluminum Windings replacing Copper Windings.

PRODUCT IDENTIFICATION

Split System Heat Pumps

DSZ16 DELUXE SPLIT Z-R410A HEAT PUMP 16 SEER	
Model/Rev	Description
DSZ160**1AA	Initial release of Deluxe Goodman 2-stage 16 SEER heat pumps with R-410A.
DSZ160241AC DSZ16036, 48, 60]1AB	Sanhua (RANCO) reversing valves.

DSZ18 DELUXE SPLIT Z-R410A HEAT PUMP 18 SEER	
Model/Rev	Description
DSZ180**1AA	Initial release of Deluxe Goodman 2-stage 18 SEER heat pumps with R-410A.
DSZ180[36, 48, 60]1AB	Sanhua (RANCO) reversing valves.

PRODUCT IDENTIFICATION

Split System Heat Pumps

VSZ13 VALUE SPLIT Z-R410A HEAT PUMP 13 SEER	
Model/Rev	Description
VSZ13**1AA	Initial release of Value Line 13 SEER heat pumps with R-410A.
VSZ130[24 & 30]1AB	Improved circuiting for effective defrost.
VSZ130[24 & 36]1BA	Initial release of models with 5mm Smart Coil™.
VSZ130[18, 42, 48]1AB VSZ130241BB VSZ130301AC	Models containing crankcase heater, CCH switch and upgraded defrost control.
VSZ130[24 & 36]1BC VSZ130301AE VSZ130[18, 42 & 48]1AD	Release of single phase models with new 6 pole motor.
VSZ130[18, 42-60]1AC VSZ130301AD	Relocation of low pressure switch from liquid line to suction line as a compressor safeguard to prevent low pressure from entering.
VSZ130241CA	Release of 2 Ton models with a compressor change from ZP21K5EPFV130 to ZP20K5EPFV130.
VSZ130181AE VSZ130421AF	Changed from four-piece louver assembly to a two piece louver assembly. Added a corner post on 26" and 29" chassis.
VSZ130361BD VSZ130301AF VSZ130481AE	Single phase models with new 6 pole motor. Changed from four-piece louver assembly to a two piece louver assembly. Added a corner post on 26" and 29" chassis.
VSZ130421AF	Compressor change from ZP36K5EPFV130 to ZP34K5EPFV130.
VSZ130241CB	2 Ton models changing from the current four piece louver assembly, to a two piece louver plus a corner post on Goodman and value series 26" and 29" chassis.
VSZ130181AF VSZ130241BD VSZ130301AG	Reversing valve change from Dunan to new SanHua.
VSZ130481AF	Ranco 0151M00020 reversing valve replaced by SanHua 0151R00070 reversing valve
VSZ130241BE	Create new Motor & Replace 0131M00294 with 0131M00800

PRODUCT IDENTIFICATION

Split System Heat Pumps

GSZ13 GOODMAN SPLIT Z-R410A HEAT PUMP 13 SEER	
Model/Rev	Description
GSZ13**1AA	Initial release with Regal Beloit motor.
GSZ13**1AB GSZ13**3AA GSZ13**4AA	Initial release with Broad Ocean motor.
GSZ130[24 & 30]1AC	Release of minor revision with improved circuiting for effective defrost.
GSZ130[24 & 36]1BA	Initial release of models with 5mm Smart Coil™.
GSZ130241CA	Release of 2 Ton models with a compressor change from ZP21K5EPFV130 to ZP20K5EPFV130.
GSZ130241CB	2 Ton models changing from the current four piece louver assembly, to a two piece louver plus a corner post on Goodman and value series 26" and 29" chassis.
GSZ130[18, 42-60]1AC GSZ130301AD GSZ130361BB	Release of models containing crankcase heater, CCH switch and upgraded defrost control.
GSZ130[18,42,48,60]1AD GSZ130301AE GSZ130[36,48,60]{3,4}AB GSZ130[48,60]{3,4}AB	Relocation of low pressure switch from liquid line to suction line as a compressor safeguard to prevent low pressure from entering.
GSZ130[18,42,48]1AF GSZ130301AG GSZ130[36,48]3AD GSZ130484AC	Changing from the current four piece louver assembly, to a two piece louver plus a corner post on Goodman and value series 26" and 29" chassis.
GSZ130361BC GSZ130[42 & 48]1AE	Release of models with new 6 pole motor/fan combination.
GSZ130361BD	Models with new 6 pole motor/fan combination. Changing from the current four piece louver assembly, to a two piece louver plus a corner post on Goodman and value series 26" and 29" chassis.
GSZ130421AF	Release of two piece louver plus corner post on 26" and 29" chassis with compressor changing from ZP36K5EPFV130 to ZP34K5EPFV130.
GSZ130[36 & 48]3AC	Release of 3 phase models with new 6 pole motor.
GSZ14**1AA	Initial release of 14 SEER models.
GSZ130481AG GSZ130483AE GSZ130484AD	Replaced Ranco reversing valve 0151M00020 with SanHua 0151R00070 reversing valve .
GSZ130[191,311] AD GSZ130241BE GSZ130251AC	Create new Motor & Replace 0131M00294 with 0131M00800

PRODUCT IDENTIFICATION

Split System Heat Pumps

GSZ14 GOODMAN SPLIT Z-R410A HEAT PUMP 14 SEER	
Model/Rev	Description
GSZ140(18-60)1KA GSZ140491AA	Introduction of ready 15 14 SEER heat pumps to meet the 2015 energy efficiency requirement.
GSZ140(18-30)1KB	Energy guide update. PCBDM160 with new software.
GSZ140301KC GSZ140361KB	Migrating from copper to aluminum motors.
GSZ140[421,491]KB	Motor change on 3 & 3.5T 14 SEER & 2 & 2.5T 16 SEER. Increase blade gap.
GSZ140181KC GSZ140361KC	Refrigerant charge reduction.
GSZ140[241,301]KD GSZ140[481,601]KB	New model revisions, GSZ140241KD, GSZ140301KD, GSZ140481KB and GSZ140601KB will have the BOMs changed and have a lower refrigerant charge.
GSZ140[241, 301]KE GSZ140[481, 601]KC	New model revisions to deplete current overstock of Ranco reversing valves
GSZ140181KD	Change from copper wound motor to aluminum wound motor.
GSZ140[421, 491]KC	Refrigerant Charge Reduction
GSZ140241KF	Equivalent motor with Aluminum Windings replacing Copper Windings.

GSZ16 GOODMAN SPLIT Z-R410A HEAT PUMP 16 SEER	
Model/Rev	Description
GSZ160[18-48]1BA	Initial release of Goodman 16 SEER, 13 EER Heat Pumps with 9.0+ HSPF
GSZ160601BA	Initial release of Goodman 5 Ton 16 SEER, 13 EER Heat Pumps
GSZ160241BB GSZ160301BB	Motor change on 3 & 3.5T 14 SEER & 2 & 2.5T 16 SEER. Increase blade gap.
GSZ160181BB	16 SEER 1.5T Heat Pumps, Remove Hard Start Kit
GSZ160181BC	Equivalent motor with Aluminum Windings replacing Copper Windings.
GSZ160181BD GSZ160[241,301]BC GSZ160[361,421,481,601]BB	Switching current Goodman 16SEER condensers and heat pumps with grille tops to louver tops to be consistent with other Goodman units having louver-style top panels.

PRODUCT IDENTIFICATION

Split System Heat Pumps

SSZ14 SPECIAL HIGH FEATURE SPLIT Z-R410A HEAT PUMP 14 SEER	
Model/Rev	Description
SSZ140**1AA	Initial release of Goodman 14 SEER Heat Pump R410A.
SSZ140**1AB	Screw locations moved in the top panel, base pans, louvers, and control box covers.
SSZ140**1AC	Broad Ocean Motors.
SSZ140181AC SSZ140241AF SSZ140301AD	Discharge line mufflers added.
SSZ140361AF SSZ140[42-60]1AD	Added discharge line mufflers. Replaced TXV and compensator with flowrator and accumulator.
SSZ140241AG	Smaller B1227315 reversing valve.
SSZ140[18, 30, 42-60]AE SSZ140241AH SSZ140361AG	Sanhua (RANCO) reversing valves.
SSZ140[18, 30, 42-60]AF SSZ140241AJ SSZ140361AH	Introduction of heat pumps with accumulators, crankcase heaters, and upgraded defrost control.
SSZ140[18,30]1AH SSZ140241AL SSZ140361BB	Changed from four-piece louver assembly to a two piece louver assembly. Added a corner post on Goodman 26" and 29" chassis.
SSZ140140[18, 30]1AJ SSZ140[19, 25]1AC SSZ140[31, 37]1AC SSZ140241AM SSZ140361BCC SSZ140381AB SSZ140140381AB SSZ140[42-60]AH	Revision made for design improvement.
SSZ140[18-60]1AD	Relocation of low pressure switch from liquid line to suction line as a compressor safeguard to prevent low pressure from entering.
SSZ140361AF SSZ140[42-60]1AD	Chassis size reduction from large to medium.
SSZ140381AA	Initial release of 35" chassis with 6-channel flowrator and ZP29K5 compressor.
SSZ140[18-30]1BA	Updated ratings and agency information.
SSZ140241BB SSZ140251AE	Change from copper wound motor to aluminum wound motor.

PRODUCT IDENTIFICATION

Split System Heat Pumps

SSZ16 SPECIAL HIGH FEATURE SPLIT Z-R410A HEAT PUMP 16 SEER	
Model/Rev	Description
SSZ160**1AA	Initial release of Goodman 16 SEER Heat Pump R410A.
SSZ160**1AB	Screw locations moved in the top panel, base pans, louvers, and control box covers.
SSZ160**1AC	Broad Ocean Motor. Updated muffler and standardized TXV. Compensator using ASZ18 SEER weldment to the SSZ160601AC.
SSZ16[024-48]1AC SSZ160601AD	Discharge line mufflers added.
SSZ160361AF SSZ160[42-60]1AD	Added discharge line mufflers. Replaced TXV and compensator with flowrator and accumulator.
SSZ160241AF SSZ160[36, 48]1AD SSZ160601AE	Sanhua (RANCO) reversing valves.
SSZ160241AF SSZ160[36-48]1AE SSZ160601BA	Introduction of heat pumps with accumulators, crankcase heaters, and upgraded defrost control.
SSZ160241AH	Changed from four-piece louver assembly to a two piece louver assembly. Added a corner post on Goodman 26" and 29" chassis.
SSZ160601BB	Ultratech® compressor
SSZ160241AK	Change from copper wound motor to aluminum wound motor.

PRODUCT IDENTIFICATION

Split System Condensers

GSX13 GOODMAN BRAND SPLIT X-R410A CONDENSERS 13 SEER	
Model/Rev	Description
GSX130**1AA	Initial release of Goodman 13 SEER R-410A Condensers with Regal Beloit motors
GSX13061[1/3/4]AA	Introduction of Goodman 13 SEER R-410A Condensers that supplement our current 5 ton models.
GSX130363AB GSX130484AB GSX130603AB GSX130604AB	Changed from the current four piece louver assembly, to a two piece louver plus a corner post on Goodman and value series 26" and 29" chassis.
GSX130**1AB	Broad Ocean motors.
GSX130483AB	3 Phase model with new 6 pole motor.
GSX130483AC	3 phase model changing from the current four piece louver assembly, to a two piece louver plus a corner post on Goodman and value series 26" and 29" chassis.
GSX130181EA GSX130181EB	Introduction of 1.5 ton condenser with Rechi Compressor.
GSX130**1BA GSX130**3AA GSX130**4AA	Introduction of Goodman 13 SEER R-410A Condensers using SmartCoil® coils. Units will have new louvers because units are smaller. Piston size change. Other components unchanged.
GSX130301BB	Replaced fan motor to -294 and fan blade to -18 on GSX130301BA models.
GSX130[42, 48]1BC GSX130301BC GSX130601BB	Changed from the current four piece louver assembly, to a two piece louver plus a corner post on Goodman and value series 26" and 29" chassis.
GSX130[42, 48]1BB	New 6 pole motor/fan combination.
GSX130181CA	Rotary compressor.
GSX130421CA GSX130481CA	Introduction of Goodman 3.5 and 4 ton 13 SEER condensing units with reciprocating compressor.
GSX130361CA	Replaced current compressor with compressor ZP29K5EPFV130.
GSX130[18-36]1DA	Condenser conversion to 23" chassis for the 1.5 - 3 ton models.
GSX130181ED	Changed from a 4 leg Rechi Compressor 50N382XV-ZAKM to 3 Leg Rechi Compressor 50N382XV-5AKM. Changed Suction line Assy from 0210R01608 to 0210R01406. This minor
GSX13031DB	Improved coil circuit assembly for greater capacity/efficiency and a new discharge tubing assembly.
GSX130361EA	Introduction of Goodman 3 ton conversion from 29" chassis to 26".
GSX130361EB	Changed from the current four piece louver assembly, to a two piece louver plus a corner post on Goodman and value series 26" and 29" chassis.
GSX130371AA	Improved decibel ratings for Canadian market.
GSX130181EF	Change from motor 0131M00276 to 0131M00593 on units GSX130181 & VSX130181
GSX130363AD	Change from copper wound motor to aluminum wound motor.
GSX130241EC GSX130301BF	Create new Motor & Replace 0131M00294 with 0131M00800

PRODUCT IDENTIFICATION

Split System Condensers

GSX14 GOODMAN BRAND SPLIT X-R410A CONDENSERS 14 SEER	
Model/Rev	Description
GSX14**1AA	Introduction of Goodman 14 SEER R-410A models.
GSX140[18-19]1KA GSX140[24-25]1KA GSX140[30-31]1KA GSX140[36-37]1KA GSX140[42, 48, 60]1KA	Goodman Split X 14 Seer Condensing units. Introducing the Goodman 14 SEER standard condenser 5mm architecture with updated scroll compressors.
GSX140241KB	Replaced 1/12hp fan motor with 1/8hp fan motor.
GSX140311AA	Introduction of 12.2 EER air conditioning units.
GSX140[30-36,42]1KB	Migrating from copper to aluminum motors.
GSX140251LA	Changed compressor from K5 to K6, Changed coil slab from 25" tall to 30" tall, Changed louvers from 24" tall to 29" tall
GSX140241LB	Create minor revisions of the new Rechi 2.0T units to consume the excess inventory of 19P fan motor
GSX140191KB	Remove HS Kit from Control Panels of condenser units with updated ZP14K6E scroll compressors.
GSX140361KC GSX140371KB GSX140421KC GSX140 [431,481,601]KB	Refrigerant charge reduction.
GSX140311KB GSX140371KC GSX140431KC	Change from copper wound motor to aluminum wound motor.

PRODUCT IDENTIFICATION

Split System Condensers

GSX16 GOODMAN BRAND SPLIT X-R410A CONDENSERS 15 AND 16 SEER	
Model/Rev	Description
GSX160**1FA	Initial release of the Goodman 16 SEER R410A Condensers.
GSX160611FA	New high capacity 5 ton model that will supplement the current GSX160601 models.
GSX160[18-61]1FB	Minor revision for GSX16s to include ball valves 0151R00045 and 0151R00046.
GSX160601GA	7mm coils.
GSX160(48/60/61)1FB	Ball valve change from 0151R00046 to 0151R00081
GSX160(18/24/30/36)1FC	Migrating from copper to aluminum motors.
GSX160(18/24/30/36)1FC GSX160(42/48/60/61)1FC	Ball Valve Re-work 0151R00045 & 0151R00046
GSX160311AA GSX160371AA	Initial release creates and launches 2 new SKUs in the 16 SEER single-stage AC product line.
GSX160[241, 301, 601]FE	Refrigerant charge reduction.
GSX160[311,371]AB	Equivalent motor with Aluminum Windings replacing Copper Windings.
GSX160[181,361,421,481,611]FE GSX160[241,301]FF GSX160[311,371]AC	Switching current Goodman 16SEER condensers and heat pumps with grille tops to louver tops to be consistent with other Goodman units having louver-style top panels.

PRODUCT IDENTIFICATION

Split System Condensers

SSX14 SPECIAL HIGH FEATURE SPLIT X-R410A CONDENSERS 14 SEER	
Model/Rev	Description
SSX140**1AA	Initial release of Goodman 14 SEER AC 410A.
SSX140**1AB	Revisions have screw locations moved in the top panel, base pans, louvers, and control box covers.
SSX14018, 241AC	Revised condenser coils by removing [1] haripin.
SSX140301AC	Model contains the Broad Ocean motor 0131M00060
SSX14036-601AC	Models contain the Broad Ocean motor 0131M00061
SSX14030,361AD	Revised condenser coils by removing [1] haripin.
SSX140421AD	Introduces SSX140421A in 29" base pan
SSX140[18-24]1BA SSX140[30-36]1BA SSX140421CA	Converts 1.5 - 3.5 ton condenser coil tubes from 3/8" tube diameter to 5mm tube diameter.
SSX140[18-36]1BC SSX140421CC	Changing from the current four piece louver assembly, to a two piece louver plus a corner post on Goodman and value series 26" and 29" chassis.
SSX140[18-36]1BD SSX140421CD SSX140481BB SSX140601AG	Revision made for design improvement.
SSX140421BA	Revision for SSZ140421B* in 29 base pan and it will the reduce the unit charge from 180 oz. to 170 oz. and replace the 1/4 hp outdoor unit motor with 1/6 hp motor.
SSX14030-421AE	Revised condenser coils by removing [1] haripin.
SSX140[18-48]1BA SSX14042-481CA	Introduction of Goodman 14 SEER R-410A Condensers with SmartCoil® Coils.
SSX140[18-36]1BB SSX140421CB SSX140601AF	Relocation of low pressure switch from liquid line to suction line as a compressor safeguard to prevent low pressure from entering.

PRODUCT IDENTIFICATION

Split System Condensers

SSX16 SPECIAL HIGH FEATURE SPLIT X-R410A CONDENSER 16 SEER	
Model/Rev	Description
SSX160**1AA	Introduces Goodman 16 SEER AC 410A
SSX160**1AB	New revisions have screw locations moved in the top panel, base pans, louvers, and control box covers.
SSX160**1AB SSX160591AA	New revisions have screw locations moved in the top panel, base pans, louvers, and control box covers.
SSX160[24, 36, 48]1BA SSX160[30 & 42]1AA	SmartCoil® coils.
SSX160[24, 36]1BC SSX160[30, 42]1AB	Changing from the current four piece louver assembly, to a two piece louver plus a corner post on Goodman and value series 26" and 29" chassis.
SSX160601BA	ZPS49K compressor.
SSX160[24,36,60]1BB	Relocation of low pressure switch from liquid line to suction line as a compressor safeguard to prevent low pressure from entering.

DSX16 DELUXE SPLIT X-R410A HEAT PUMP 16 SEER	
Model/Rev	Description
DSX160**1AA	Initial release of Goodman 2-stage, 16 SEER condensing units with R-410A.
DSX160[24, 36]1BA	Conversion of 2 & 3 ton models to SmartCoil® Coils.
DSX160241BC	Introduces Ultratech® 2.0 compressor changes.

DSX18 DELUXE SPLIT X-R410A HEAT PUMP 18 SEER	
Model/Rev	Description
DSXC18**1AA	Initial release of 2-stage condensing units with R-410A communicating models.
DSXC18036AB DSXC18048AB DSXC18060AB	Updated wiring diagram with notes for communicating condensing units.
DSXC18036AC	Replaced existing compressor ZPS20K4EPFV230 to ZPS20K5EPFV130 & existing compressor ZPS30K4EPFV230 to ZPS30K5EPFV130 for communicating condensing units.
DSXC180[48-60]AC	Initial release of Ultratech 2.0 to communicating condensing units

PRODUCT IDENTIFICATION

Split System Condensers

VSX13 VALUE SPLIT X-R410A CONDENSER 13 SEER	
Model/Rev	Description
VSX130[18-48]1AA	Introduces Value Line 13 SEER condensing units with R-410A.
VSX130611AA	Supplements the 5 ton model GSX130611 to enhance performance.
VSX130301AB	Replaced fan motor to -294 and fan blade to -18 on the VSX130301AA.
VSX130301AC VSX130[42-48]1AC	Changed from current four piece louver assembly to a two piece louver assembly plus a corner post on Goodman and value series 26" and 29" chassis.
VSX130[42-48]1AB	Replaced with 6-pole motor and Copeland compressor.
VSX130181BA	Rotary compressor.
VSX130181EA VSX130181EB	Introduction of 1.5 ton condenser with Rechi Compressor.
VSX130181ED	Changed 4-leg Rechi Compressor 50N382XV-ZAKM to 3-Leg Rechi Compressor 50N382XV-5AKM. Changed Suction line Assy from 0210R01608 to 0210R01406.
VSX130241BA	2.0 ton condensing units with aluminum coils, aluminum manifolds w/existing scroll compressor.
VSX130361BA	Replaced current compressor with compressor ZP29K5EPFV130.
VSX130361EB	Changed from current four piece louver assembly, to a two piece louver plus a corner post on Goodman and value series 26" and 29" chassis.
VSX130601BA	Condensing units with SmartCoil® coils.
VSX130601BB	Changing from the current four piece louver assembly, to a two piece louver plus a corner post on Goodman and value series 26" and 29" chassis.
VSX130421BA VSX130481BA	3.5 and 4 ton 13 SEER condensing units with reciprocating compressor.
VSX130[18-36]1DA	3.5 and 4 ton 13 SEER Condensers conversion to 23" chassis for the 1.5 - 3 ton models.
VSX130301DB	2.5 13 SEER Condensers with improved coil circuit assembly for greater capacity/efficiency and the creation of a new discharge tubing assembly.
VSX130301EA	3 Ton 13 SEER Condensers release of 3 ton models converting from 29" chassis to 26" chassis.
VSX130241EA	2.0 Ton 13 SEER Condensers with Rechi Compressor, converting 23" chassis to 26" chassis
VSX130371AA	2.5 13 SEER Condensers with improved decibel ratings for Canadian market.
VSX130241EB	Compressor wires yellow, red and black changing from 40" to 45".
VSX130181EF	Change from motor 0131M00276 to 0131M00593 on units GSX130181 & VSX130181
VSX130241ED VSX130301AF	Create new Motor & Replace 0131M00294 with 0131M00800

PRODUCT IDENTIFICATION

Split System Condensers

VSX14 VALUE SPLIT X-R410A CONDENSER 13 SEER	
Model/Rev	Description
VSX140[18-19]1AA VSX140[24-25]1AA VSX140[30-31]1AA VSX140[36-37]1AA VSX140[42, 48, 60]1AA	Introducing the 14 SEER standard condenser 5mm architecture with updated scroll compressors.
VSX140241AB	Replaced 1/12hp fan motor with 1/8hp fan motor.
VSX140251BA	Changed compressor from K5 to K6, Changed coil slab from 25" tall to 30" tall, Changed louvers from 24" tall to 29" tall
VSX140241BB	Create minor revisions of the new Rechi 2.0T units to consume the excess inventory of 19P fan motor
VSX140191KB	Remove HS Kit from Control Panels of condenser units with updated ZP14K6E scroll compressors.
VSX140[301, 311]AB VSX140[361-431]AC	Change from copper wound motor to aluminum wound motor.
VSX140301BA	Copeland to Rechi 2.5 T update suct tube, fix liq line assy, fix wiring diagram, change charge qty.

PRODUCT IDENTIFICATION

Split System Condensers

ANX13 AMANA® BRAND SPLIT SYSTEM N-BASE X-R410A CONDENSERS 13 SEER	
Model/Rev	Description
ANX130[18-24]1AA	Launch of the Tier 1.5T & 2.0T models. Launched with 26" chasis to accommodate horizontal style louvers.
ANX130[30-61]1AA	Initial release.
ANX130241BA	Convert ANX13/14 1.5 and 2 ton models to Rechi compressors.
ANX130[301-601]AD	Refrigerant Charge Reduction
ANX130241BB ANX130301AE	Create new Motor & Replace 0131M00294 with 0131M00800

ANX14 AMANA® BRAND SPLIT SYSTEM N-BASE X-R410A CONDENSERS 14 SEER	
Model/Rev	Description
ANX140[18-60]1AA	Introducing the Amana® Brand 14 SEER standard condenser 5mm architecture with updated scroll compressors.
ANX140241AB	Replaces 1/12hp fan motor with 1/8hp fan motor.
ANX140431AA	Introduction of ready 15, 12.2 EER air conditioning units.
ANX140251BA	Changed compressor from K5 to K6, Changed coil slab from 25" tall to 30" tall, Changed louvers from 24" tall to 29" tall
ANX140191AB	Remove HS Kit from Control Panels of condenser units with updated ZP14K6E scroll compressors.
ANX140181BA ANX140241BA	Convert ANX13/14 1.5 and 2 ton models to Rechi compressors.
ANX140[301-371]AB ANX140[421,431]AB	Change from copper wound motor to aluminum wound motor.
ANX140481AB ANX140601AB	Refrigerant Charge Reduction
ANX140[361,371]AC ANX140[421,431]AC	Refrigerant Charge Reduction

PRODUCT IDENTIFICATION

Split System Condensers

ASX13 AMANA® BRAND SPLIT X-CONDENSERS 13 SEER	
Model/Rev	Description
ASX130**1AA	Initial release new models of Amana® Brand Deluxe 13 SEER AC R410A conditioners.
ASX130611AA	Initial release of new models of Amana® Brand Deluxe 13 SEER AC R410A conditioners; replaced ASX130601* models.
ASX130611AA	Introduction of Amana® brand 13 SEER R-410A Condensers that supplement our current 5 ton models.
ASX130**1BA	Initial release of models using SmartCoil® coils. Smaller units with new louvers. Piston size changed; other components unchanged.
ASX130**1CB	Relocation of low pressure switch from liquid line to suction line. Compressor safeguard to prevent low pressure from entering.
ASX130181DA	Initial release of models with new 266 fan motor; Low pressure switch removed.
ASX130181DB ASX130[24-48]1CD ASX130601CC	Low pressure switch 013M00082 added; updated wiring diagram.
ASX130[24-48]1CC ASX130601CB	Initial release of models with single speed PSC motors; Does not contain a low pressure switch, low ambient temperature switch and relay.
ASX130361DA	Release of 3 ton models with a 26" chassis.
ASX130361DE	Refrigerant Charge Reduction

PRODUCT IDENTIFICATION

Split System Condensers

ASX14 AMANA® BRAND SPLIT X-CONDENSERS 14 SEER	
Model/Rev	Description
ASX140**1AA	Initial release of models of Amana® Brand Deluxe 14 SEER AC R410A conditioners.
ASX140**1AB	Screw locations moved in the top panel, base pans, louvers, and control box covers.
ASX140**1AC	Horizontal style louvers.
ASX14018-361AD	Revised condenser coils by removing (1) hairpin. R410A quantity reduced by 6 ounces.
ASX140421AD	Initial release of model ASX140421A in 29" base pan
ASX140421BA	29" platform. Unit charge reduced from 180 oz. to 170 oz. 1/4 hp outdoor unit motor replaced with 1/6 hp motor.
ASX14018-361BA ASX140[42-48]1CA	1.5 - 3.5 ton condenser coil tubes converted from 3/8" tube diameter to 5mm tube diameter.
ASX140[18-30]1BA ASX140[42-48]1CA	Initial release of models using SmartCoil® coils.
ASX140[18-36]1CB ASX140421DB ASX140601BB	Low pressure switch relocated from liquid line to suction line as a compressor safeguard to prevent low pressure from entering.
ASX140[24-36]1CC ASX140421DC ASX140481CB ASX140601BC	Initial release of models with single speed PSC motors; Does not contain a low pressure switch, low ambient temperature switch and relay.
ASX140181DB ASX140[24-36]1CD ASX140421DD ASX140481CC ASX140601BD	Low pressure switch added.
ASX140181DD ASX140[24-48]1CE ASX140421DE ASX140601BE	Design improvement.
ASX140181DA	Initial release of models with new 266 fan motor; Low pressure switch removed.
ASX140[18-19, 24-25]1KA ASX140[30-31, 36-37]1KA ASX140[42, 48, 60]1KA	Initial release of 5mm architecture with updated scroll compressors.
ASX140241KB	1/8 hp fan motor replaced 1/12 hp fan motor.

PRODUCT IDENTIFICATION

Split System Condensers

ASX14

AMANA® BRAND SPLIT X-CONDENSERS 14 SEER

Model/Rev	Description
ASX140[18-19, 24-25]1KA ASX140[30-31, 36-37]1KA ASX140[42, 48, 60]1KA	Initial release of 5mm architecture with updated scroll compressors.
ASX140241KB	1/8 hp fan motor replaced 1/12 hp fan motor.
ASX140241LA ASX140251LA	Changed compressor from K5 to K6, Changed coil slab from 25" tall to 30" tall, Changed louvers from 24" tall to 29" tall
ASX140191KB	Remove HS Kit from Control Panels of condenser units with updated ZP14K6E scroll compressors.
ASX140241LA	Change compressor from K6 to K5 on ASX140241 and DX14SA0241
ASX 140[301-431]KB	Change from copper wound motor to aluminum wound motor.
ASX 140[481, 601]KB	Refrigerant Charge Reduction
ASX 140[361,371,421,431]KC ASX160[241,301]FC	Refrigerant Charge Reduction

PRODUCT IDENTIFICATION

Split System Condensers

ASX16 AMANA® BRAND SPLIT X-CONDENSERS 16 SEER	
Model/Rev	Description
ASX160**1AB	Screw locations moved in the top panel, base pans, louvers, and control box covers.
ASX160**1AC	Horizontal style louvers.
ASX160**1FA	Single speed outdoor fan.
ASX160611FA	High capacity 5 ton models that supplement the current ASX160601 models.
ASX160611GA	7mm coils.
ASX160[24-60]1BA	Wiring diagram updated with notes.
ASX160[24/36]1CA	Initial release of Conversion of 2 & 3 ton models to SmartCoil® coils.
ASX160(48/60/61)1FB	Ball valve change from 0151R00046 to 0151R00081
ASX160311AA ASX160371AA	Initial release creates and launches 2 new SKUs in the 16 SEER single-stage AC product line.
ASX160[181-421]FB	Change from copper wound motor to aluminum wound motor.
ASX160601FC	Refrigerant charge reduction
ASX160[311,371]AB	Equivalent motor with Aluminum Windings replacing Copper Windings.

ASX18 AMANA® BRAND SPLIT X-CONDENSERS 18 SEER	
Model/Rev	Description
ASX180**1AB	Initial release new models of Amana® Brand Deluxe 18 SEER AC R410A conditioners.

PRODUCT IDENTIFICATION

Air Handlers

ACNF A-SINGLE PIECE AIR HANDLER CEILING MOUNT N-UNCASED FLOWATER	
Model/Rev	Description
ACNF****1AA	Release of all models of 13 SEER Dayton uncased air handlers.
ACNF****16AA	Release of all models of 13 SEER Dayton uncased air handlers suitable for use with R-22 & R-410A.
ACNF****1AB	Drain pan material change.
ACNF****1BA	Current wavy fin design with replaced new louvered fin design
ACNF****16DA	Converted copper coils, manifolds, hairpins, flowrators, 90° flowrator stub to aluminum. Conversion of copper 3/8" return bends to aluminum 5/16" return bends.
ACNF180[51-81]6DB ACNF240[51-81]6DB ACNF241016DB ACNF300[51-81]6DB ACNF301016DB	UL1995 heater change.
ACNF250[01/05/06/08/]16AA ACNF251016AA ACNF310[01/05/06/08/10]16AA	Change in the air handler design. The motor changed from an existing PSC to a constant torque motor.

ADPF A-SINGLE PIECE DOWNFLOW AIR HANDLER PSC MOTOR PAINTED FLOWATER	
Model/Rev	Description
ADPF****16AA	Introduction of new 13 SEER Air Handler Models suitable for use with R-22 and R-410A.
ADPF364216AB	Replacement of the current spot welded blower housing with the same cinched or crimped design used on the 80% furnace line.
ADPF486016AB	Replacement of the current spot welded blower housing with the same cinched or crimped design used on the 80% furnace line.
ADPF304216AC	Replacement of the current spot welded blower housing with the same cinched or crimped design used on the 80% furnace line.
ADPF****1BA	Replacement of all ARPFcoils using way fin with louver enhanced fin.
ADPF182416CA ADPF486016CA	Replacement of existing air handler copper coils and other associated parts with aluminum components.

PRODUCT IDENTIFICATION

Air Handlers

AEPF A-SINGLE PIECE E-MULTI-POSITION VARIABLE SPEED PAINTED FLOWATER	
Model/Rev	Description
AEPF****16AA	Introducation of new 13 SEER Air Handler Models suitable for use with R-22 and R-410A.
AEPF****16BA	Introduction of new models adding lower kW hit kits on the S&R plate.
AEPF****16BB	Replacement of the current spot welded blower housing with the same cinched or crimped design used on the 80% furnace line.
AEPF****16CA	Replacement of all ARPFcoils using wavy fin with louver enhanced fin.
AEPF****1BA	Introduction of R-22 Only Air Handlers.
AEPF313716AA	Introduction of 3-Ton Air Handler units with 3-row coil.

PRODUCT IDENTIFICATION

Air Handlers

ARUF	
A-SINGLE PIECE AIR HANDLER R-MULTI-POSITION PSC MOTOR UNPAINTED FLOWRATOR	
Model/Rev	Description
ARUF172916AA A24-00-2RCA	Introduction of new Air Handler Models with all aluminum evaporator coils. Conversion includes coils, manifold, hairpin, flowrators, 3/8" return bend to 5/16" aluminum return bends.
ARUF****16AA	Introduction of new 13 SEER Air Handler Models suitable for use with R-22 and R-410A
ARUF364216AB ARUF486016AB ARUF364216AC	Replaced current spot welded blower housing with cinched/crimped design used on the 80% furnace line.
ARUF****16BA	Replaced way fin with louver enhanced fin.
ARUF****1BA	Introducation of R-22 Only Air Handlers.
ARUF****16CA	Replaced existing air handler copper coils and other associated parts with aluminum components.
ARUF***14AA ARUF***14AB	Initial release of the redesigned air handlers manufactured at the Houston furnace facility.
ARUF18B14AB ARUF24B14BA ARUF36C14BA ARUF42C14AB	R-410A only. 2 & 3 ton coil replacement. 2 ton replaced w/3 row/16" tall; 3 ton replaced with 18" tall coil. 3.5 ton model blower motor changes from 10X8 to 10X10.
ARUF24B14BB	Changed 16 Tall, 3 Row, 6 Cir Coil Assembly to 14 Tall, 3 Row , 6 Cir Coil Assembly.
ARUF24B14CA	Initial release of model to meet AHRI requirements
ARUF30C14BA	ARUF30B, 17.5 inch wide models converted to an ARUF30C, 21 inch wide model.
ARUF36C14BB ARUF42C14AC	The aluminum models changes the RBs, COs, and coil slabs to 9mm braze joints.
ARUF36C14BC ARUF30B14AC ARUF30C14BB ARUF42C14AD ARUF(48/60)D14AC	Serial plate changes
ARUF(37/43/49)C14AA	Initial release of new ready 2015 Air Handler Models that meet the 2015 energy efficiency levels (for 7mm 14 SEER Heat Pumps).
ARUF(37/43/49)D14AA	Initial Release. D53 Cabinet (for 7mm 14 SEER Heat Pumps).
ARUF(47/61)D14AA	Initial release of new ready 2015 Air Handler Models that meet the 2015 energy efficiency levels (for 7mm 14 SEER Heat Pumps).

ARPF	
A-SINGLE PIECE AIR HANDLER R-MULTI-POSITION PSC MOTOR PAINTED FLOWRATER	
Model/Rev	Description
ARPF364216AB ARPF486016AB	Replacement of the current spot welded blower housing with the same cinched or crimped design used on the 80% furnace line.
ARPF****16BA	Way fin replaced with louver enhanced fin.
ARPF****1BA	Introduction of R-22 Only Air Handlers.
ARPF****16CA	Replaced air handler copper coils and other associated parts with aluminum components.

PRODUCT IDENTIFICATION

Air Handlers

ARPT - R410A ONLY	
A-SINGLE PIECE AIR HANDLER R-MULTI-POSITION PSC MOTOR PAINTED FLOWRATER TXV	
Model/Rev	Description
ARPT***14AA	Initial release of the new air handlers.
ARPT***14AB	Initial release of the air handlers manufactured at the Houston furnace facility.
ARPT[18-36]B14AC ARPT[36-60]D14AC	Serial plate changes.

ASPF	
A-SINGLE PIECE AIR HANDLER S-MULTI-POSITION EEM MOTOR PAINTED FLOWRATOR	
Model/Rev	Description
ASPF****16AA	Introduction of new ASPF Air Handlers.
ASPF****16BA	Initial release of modified ASPF control scheme, to ensure blower operation during and after call for heat on units with heat kits and replacing way fin with louver enhanced fin on coil.
ASPF****16CA	Replaced existing air handler copper coils and other associate departs with aluminum components.
ASPF****16DA	Initial release of models with Emerson SelecTech motor. Replaced Regal-Beloit X-13 motor.
ASPF****16EA	Replaced of existing air handler copper coils and other associated parts with aluminum components and replaced Regal-Beloit X-13 motor with Emerson SelecTech motor.

ASPT	
A-SINGLE PIECE AIR HANDLER S-MULTI-POSITION EEM MOTOR PAINTED TXV	
Model/Rev	Description
ASPT(24/36/48/60)*14	Introduction of new generation ASPT air handlers.
ASPT36C14AB ASPT(48/60)D14AB ASPT48D14AC	9mm return bend coil changes to new generation of ASPT air handlers.
ASPT24B14AC ASPT30C14AB ASPT36C14AC	Programmed Broad Ocean Motor. The supplier can program the motor instead of furnace plant, thus eliminating any programming installing issues. The programmed label will provide by supplier.
ASPT(24/36)B14AD ASPT30C14AC ASPT(42-48)C14AB	X13 Motor IP changed to IGBT (Broad Ocean).
ASPT(42-48)C14AA	Initial release of models with 2+2 coil slab assy. These models are required to meet higher tonnage rating in Cabinet.
ASPT42D14AB ASPT48D14AD ASPT60D14AC	Nidec Pre-programmed Motor. Nidec motor can be programmed by the supplier instead of programming at the furnace plant, thus eliminating any programming installing issues.
ASPT(25/29/37)B14AA ASPT(37/47/59)C14AA ASPT(47/49/61)D14AA	Initial release of models with a 2 slab, low airflow resistant coil with a fixed speed ECM. 53" cabinet size. ASPT42C and ASPT48C 2+2 models discontinued.

PRODUCT IDENTIFICATION

Air Handlers

ASUF	
A-SINGLE PIECE AIR HANDLER S-ENERGY EFFICIENT MOTOR UNPAINTED FLOWRATOR	
Model/Rev	Description
ASUF29B14AA ASUF39C14AA	Initial release of models in the mid-range efficiency air handler. Incorporates smart frame chassis with EEM (X-13) style motors and piston type flowrators.
ASUF49C14AA ASUF59D14AA	Initial release of mid-range efficiency air handler with X-13 motor & fixed orifice flowrator.
ASUF49C14AB ASUF59D14AB	9 mm return bend coil.
ASUF59D14AC	Four row, piston, 9 mm return bend coil.
ASUF59D14AD	Nidec Pre-programmed Motor. Nidec motor can be programmed by the supplier.
ASUF29B14AB ASUF39C14AB ASUF49C14AC	Programmed Broad Ocean Motor. The supplier can program the motor.
ASUF29B14AC ASUF39C14AC ASUF49C14AD	Changed from X13 Motor IP to IGBT (Broad Ocean).

MBR	
MODULAR BLOWER AIR HANDLER R-MULTI-POSITION PSC MOTOR	
Model/Rev	Description
MBR****AA-1AA	Initial release of a module blower with PSC blower motor.
MBR****AA-1AB	A quality improvement to use 0.75" Quiet Flex Insulation.
MBR****AA-1AC	Release of MBR/MBVC Models(Minor Revisions) for 11th St Plant. Dayton to Houston

MBE	
MODULAR BLOWER AIR HANDLER E-MULTI-POSITION VARIABLE-SPEED	
Model/Rev	Description
MBE****AA-1AA	Introduction of a module blower with variable speed blower motor.
MBE****AA-1BA	Introduction of new models adding lower kW hit kits on the S&R plate.

PRODUCT IDENTIFICATION

Air Handlers

AWUF A-SINGLE PIECE AIR HANDLER WALL MOUNT UNPAINTED FLOWRATOR	
Model/Rev	Description
AWUF****16AA AWUF370**16AA	Introduction of a 13 SEER Dayton wall mount air handlers suitable for use with R-22 and R-410A. Coil adapters have been added to coil circuits.
AWUF3005-101AA	Initial release of modelw with Burr Oak Louvered Fin coil.
AWUF****1BA AWUF****16BA	Changed from copper tube hairpin to aluminum tube hairpin. Aluminum manifolds and flowrators are purchased parts.
AWUF(18/24/30)0316BA	Introduction of 3 kW heater in the AWUF air handlers.
AWUF310516AA AWUF310816AA AWUF321016AA	Introduction of higher 14 SEER AWUF series air-handlers.
AWUF300(3/5/8/10)16BB AWUF360(5/8/10)16BB	Replaced 16x20x1 with 18x20x1 filter.
AWUF18F(3/5/8)16AA AWUF24F(1/3/5/8)16AA AWUF30F(1/5/8)16AA AWUF31F(5/8)16AA AWUF32F116AA AWUF36F(1/5/8)16AA AWUF37(1/5/8)16AA	Drain pan water sensor switch added.
AWUF180(3/5/8)16BB AWUF240(3/5/8/10)16BB AWUF300(5/8/10)16BC AWUF310(5/8/10)16AB AWUF360(5/8/10)16BC AWUF370(5/8/10)16BB	Revised for the UL1995 heater changes.
AWUF19**16A* AWUF25**16A*	Introduction of 14 SEER Dayton small chassis wall mount air handlers with fixed speed X13 Stylemotor to match the 1.5 and 2.0 ton AC, AC+EER, and HP models with factory installed heat from 3 kW to 10 kW.
AWUF180[316,516,816]BC AWUF190[316,516,816]AB AWUF240[316,516,816]BC AWUF241016BC AWUF250[316,516,816]AB AWUF251016AB AWUF300[516,816]BD AWUF301016BD AWUF310[516,816]AC AWUF321016AC AWUF360[516,816]BD AWUF361016BD AWUF370[516,816]BC AWUF371016BC	Release gasket and caps to seal leak. With this modification we will able to meet 2% at 1 inch static leak and 1.4% leak rate at 0.5 inch static. Modified all current AWUF units to pass current air leak rate.

PRODUCT IDENTIFICATION

Coils

CAUF C-INDOOR COIL A-UPFLOW/DOWNFLOW UNCASSED FLOWRATOR	
Model/Rev	Description
CAUF*****6AA	Initial release of CAUF Dayton Upflow/Downflow coils.
CAUF*****6BA	Burr Oak Louvered Fin released in place of the Wavy Fin.
CAUF****6*DA	Replaced existing copper coils and other associated parts with aluminum components.
CAUF*****6DB	Drain pan material changed.
CAUF1824(A/B/C)6RDB CAUF3636(A/B)6RDB CAUF3636(C/D)6RDB CAUF3642(C/D)6RDB CAUF3743(C/D)6RDB CAUF4860(C/D)6RDB CAUF4961(C/D)6RDB	Manufacturing Location Change from Dayton to Houston. Designated by "R".
CAUF3137B6RAA	Manufacturing Location Change from Dayton to Houston. Designated by "R".
CAUF36***CA	Redesign from 2 row to 3 row for performance improvement .

CAPF C-INDOOR COIL A-UPFLOW/DOWNFLOW PAINTED FLOWRATOR	
Model/Rev	Description
CAPF*****6AA	Initial release of CAPF Dayton Upflow/Downflow coils.
CAPF*****6BA	Burr Oak Louvered Fin released in place of the Wavy Fin.
CAPF36***CA	Redesigned for performance improvement from 2 row to 3 row.
CAPF*****6DA	Replaced existing copper coils and other associated parts with aluminum components.
CAPF*****6DB	Drain pan material changed.

CHPF C-INDOOR COIL HORIZONTAL A-COIL PAINTED FLOWRATOR	
Model/Rev	Description
CHPF*****6AA	Initial release of 13 SEER CHPF horizontal A coil.
CHPF*****6BA	Released Burr Oak Louvered Fin in place of the Wavy Fin. The rows changed by one, (i.e. 4 row to 3 row; 3 row to 2 row) where applicable.
CHPF1824A6CB CHPF2430B6CB CHPF3636B6CB CHPF3642C6CB CHPF3642D6CB CHPF3743C6BB CHPF3743D6BB CHPF4860D6DB	Drain pan material changed.

PRODUCT IDENTIFICATION

Coils

CSCF C-INDOOR COIL S-HORIZONTAL SLAB COIL UNPAINTED FLOWRATOR	
Model/Rev	Description
CSCF****6AA	Release 13 SEER CSCF slab horizontal coil.
CSCF****6BA	Burr Oak Louvered Fin released in place of the Wavy Fin. The rows change by one, (i.e. 4 row to 3 row; 3 row to 2 row) where applicable.
CSCF1824N6BB CSCF3036N6BB CSCF3642N6CB CSCF4860N6CB	Drain pan material change.
CSCF3642N6CA CSCF4860N6CA	Release 13 SEER CSCF slab horizontal coil. Louvered fin project.
CSCF1824N6DA CSCF3036N6DA CSCF3642N6DA CSCF4860N6DA	Release 13 SEER CSCF slab horizontal coil. Converting copper coils, maifolds, haripins, flowrators to aluminum coils.

CTPF C-INDOOR COIL T-COATED PAINTED FLOWRATOR	
Model/Rev	Description
CTPF****6AA	Initial release of coated coils.
CTPF1824*6AB CTPF3030*6AB CTPF3131*6AB CTPF3636*6AC CTPF3642*6AB CTPF4860*6AB	Drain pan material change.

CTUF C-INDOOR COIL T-COATED UNPAINTED FLOWRATOR	
Model/Rev	Description
CTUF1824*6AA CTUF3030*6AA CTUF3131*6AA CTUF3636*6AA CTUF3642*6AA CTUF4860*6AA	Initial release.
CTUF1824*6AB CTUF3030*6AB CTUF3131*6AB CTUF3636*6AC CTUF3642*6AB CTUF4860*6AB	Initial release.

ACCESSORIES

LIGHT COMMERCIAL

GSX11

Model	Description	GSX110903	GSX110904	GSX111203	GSX111204
FSK01A*	Freeze Protection Kit	x	x	x	x
ASC01	Anti Short Cycle Kit	x	x	x	x
LAKT-01	Low Ambient Kit	x	x	x	x
LSK03*	Liquid Line Solenoid Kit	x	x	x	x

GSZ11

Model	Description	GSZ110903	GSZ110904	GSZ111203	GSZ111204
FSK01A*	Freeze Protection Kit	x	x	x	x
ASC01	Anti Short Cycle Kit	x	x	x	x
OT-EHR18-60	Emergency Heat Relay Kit	---	---	---	---
LAKT-01	Low Ambient Kit	x	x	x	x
LSK03*	Liquid Line Solenoid Kit	x	x	x	x

ELECTRIC HEATER KITS

AHKD Model	Nominal kW	Electrical Characteristics	Stages	Weight (lbs.)	Max. Overcurrent Protection
AHKD15-3	15	208-230/3/60	1	56	60
AHKD15-4	15	460/3/60	1	55	30
AHKD20-3	20	208-230/3/60	2	59	70
AHKD20-4	20	460/3/60	2	57	35
AHKD30-3	30	208-230/3/60	2	60	100
AHKD30-4	30	460/3/60	2	58	50

NOTES:

- AR Series Air Handlers do not have factory installed electric heat. Purchased as an accessory, these are the ONLY heater kits that can be used with the AR Series.
- The electrical characteristics of the air handler, electric heater kits and building power supply must be compatible.

ACCESSORIES

ASX13

Model	Description	ASX13 018*	ASX13 024*	ASX13 030*	ASX13 036*	ASX13 042*	ASX13 048*	ASX13 060*/061*
ABK-20 ¹	Anchor Bracket Kit	X	X	X	X	X	X	X
ASC01	Anti-Short Cycle Kit	X	X	X	X	X	X	X
CSR-U-1	Hard-start Kit	X	X	X	X			
CSR-U-2	Hard-start Kit				X	X		
CSR-U-3	Hard-start Kit						X	X
FSK01A ²	Freeze Protection Kit	X	X	X	X	X	X	X
LSK02A	Liquid Line Solenoid Kit	X	X	X	X	X	X	X
TX2N4A ³	TXV Kit	X	X					
TX3N4 ³	TXV Kit			X	X			
TX5N4 ³	TXV Kit					X	X	X

G/SX13

Model	Description	GVSX13 018*	GVSX13 024*	GVSX13 030*	GVSX13 036*	GVSX13 042*	GVSX13 048*	GVSX13060* GSX13061*
ABK-20 ¹	Anchor Bracket Kit	X	X	X	X	X	X	X
ABK-21 ⁴	Anchor Bracket Kit	X	X	X	X			
ASC01	Anti-Short Cycle Kit	X	X	X	X	X	X	X
CSR-U-1	Hard-start Kit	X	X	X	X			
CSR-U-2	Hard-start Kit				X	X		
CSR-U-3	Hard-start Kit						X	X
FSK01A ¹	Freeze Protection Kit	X	X	X	X	X	X	X
LSK02A	Liquid Line Solenoid Kit	X	X	X	X	X	X	X
TX2N4A ³	TXV Kit	X	X					
TX3N4 ²	TXV Kit			X	X			
TX5N4 ²	TXV Kit					X	X	X
CSB-15	Sound Blanket Kit					X	X	X
CSB-16	Sound Blanket Kit	X	X	X	X			

GSX13 Three-Phase models

Model	Description	GSX13 0363*	GSX13 0483*	GSX13 0484*	GSX130 [60/61]3*	GSX130 [60/61]4*
ABK-20 ¹	Anchor Bracket Kit	X	X	X	X	X
ASC01	Anti-Short Cycle Kit	X	X	X	X	X
FSK01A ²	Freeze Protection Kit	X	X	X	X	X
LSK02A	Liquid Line Solenoid Kit	X	X	X	X	X
TX3N4 ³	TXV Kit	X				
TX5N4 ³	TXV Kit		X	X	X	X
CSB-15	Sound Blanket Kit		X	X	X	X
CSB-16	Sound Blanket Kit	X				
LAKT01	Low Ambient Kit	X	X	X	X	X
0163R00002	Crankcase Heater Kit	X				
0163R00003	Crankcase Heater Kit		X	X		
0163R00004	Crankcase Heater Kit				X	X

¹ Contains 20 brackets; four brackets needed to anchor unit to pad

² Installed on indoor coil.

³ Field-installed, non-bleed, expansion valve kit - Condensing units and heat pumps with reciprocating compressors require the use of start-assist components when used in conjunction with an indoor coil using a non-bleed thermal expansion valve refrigerant.

⁴ For use on the GSX13 & VSX13 23" chassis only. Contains 20 brackets; four brackets needed to anchor unit to pad.

ACCESSORIES

ASX14

Model	Description	ASX14 018	ASX14 024	ASX14 030	ASX14 036	ASX14 042	ASX14 048	ASX14 060
ABK-20 ¹	Anchor Bracket Kit	X	X	X	X	X	X	X
ASC01	Anti-Short Cycle Kit	X	X	X	X	X	X	X
CSR-U-1	Hard-start Kit	X	X	X	X			
CSR-U-2	Hard-start Kit				X	X		
CSR-U-3	Hard-start Kit						X	X
FSK01A ¹	Freeze Protection Kit	X	X	X	X	X	X	X
LSK02A	Liquid Line Solenoid Kit	X	X	X	X	X	X	X
TX2N4A	TXV Kit	X	X					
TX3N4	TXV Kit			X	X			
TX5N4	TXV Kit					X	X	X

GSX14

Model	Description	GSX14 018	GSX14 024	GSX14 030	GSX14 036	GSX14 042	GSX14 048	GSX14 060
ABK-20 ¹	Anchor Bracket Kit	X	X	X	X	X	X	X
ASC01	Anti-Short Cycle Kit	X	X	X	X	X	X	X
CSR-U-1	Hard-start Kit	X	X	X	X			
CSR-U-2	Hard-start Kit				X	X		
CSR-U-3	Hard-start Kit						X	X
FSK01A ¹	Freeze Protection Kit	X	X	X	X	X	X	X
LSK02A	Liquid Line Solenoid Kit	X	X	X	X	X	X	X
TX2N4A	TXV Kit	X	X					
TX3N4	TXV Kit			X	X			
TX5N4	TXV Kit					X	X	X
CSB-14	Sound Blanket Kit						X	X
CSB-16	Sound Blanket Kit	X	X	X	X	X		

SSX14

Model	Description	SSX14 018	SSX14 024	SSX14 030	SSX14 036	SSX14 042	SSX14 048	SSX14 060
ABK-20 ¹	Anchor Bracket Kit	X	X	X	X	X	X	X
ASC01	Anti-Short Cycle Kit	X	X	X	X	X	X	X
CSR-U-1	Hard-start Kit	X	X	X	X			
CSR-U-2	Hard-start Kit				X	X		
CSR-U-3	Hard-start Kit						X	X
FSK01A ¹	Freeze Protection Kit	X	X	X	X	X	X	X
LSK02A	Liquid Line Solenoid Kit	X	X	X	X	X	X	X
TX2N4A	TXV Kit	X	X					
TX3N4 ²	TXV Kit			X	X			
TX5N4 ²	TXV Kit					X	X	X

¹ Installed on indoor coil

² Require for heat pump applications where ambient temperatures fall below 0°F with 50% or higher relative humidity.

ACCESSORIES

SSX16

Model	Description	SSX16 024*	SSX16 030*	SSX16 036*	SSX16 042*	SSX16 048*	SSX16 060*
ABK-20 ¹	Anchor Bracket Kit	X	X	X	X	X	X
ASC01	Anti-Short Cycle Kit	X	X	X	X	X	X
CSR-U-1	Hard-start Kit	X	X	X			
CSR-U-2	Hard-start Kit			X	X		
CSR-U-3	Hard-start Kit					X	X
FSK01A ¹	Freeze Protection Kit	X	X	X	X	X	X
LSK02A	Liquid Line Solenoid Kit	X	X	X	X	X	X
TX2N4A	TXV Kit	X					
TX3N4	TXV Kit		X	X			
TX5N4	TXV Kit				X	X	X

¹ Installed on indoor coil
humidly.

ASX16/DSX16

Model	Description	A/DSX16 024*	A/DSX16 030*	A/DSX16 036*	A/DSX16 042*	A/DSX16 048*	A/DSX16 060*
ABK-20 ¹	Anchor Bracket Kit	X	X	X	X	X	X
ASC01	Anti-Short Cycle Kit	X	X	X	X	X	X
CSR-U-1	Hard-start Kit	X	X	X			
CSR-U-2	Hard-start Kit			X	X		
CSR-U-3	Hard-start Kit					X	X
FSK01A ¹	Freeze Protection Kit	X	X	X	X	X	X
LSK02A	Liquid Line Solenoid Kit	X	X	X	X	X	X
TX2N4A	TXV Kit	X					
TX3N4	TXV Kit		X	X			
TX5N4	TXV Kit				X	X	X

¹ Installed on indoor coil
humidly.

ASX/GSX16 (Rev F or Later)

Model	Description	A/GSX16 018F*	A/GSX16 024F*	A/GSX16 030F*	A/GSX16 036F*	A/GSX16 042F*	A/GSX16 048F*	A/GSX16 060F*	A/GSX16 061F*
ABK-20	Anchor Bracket Kit	X	X	X	X	X	X	X	X
ASC01	Anti-Short Cycle Kit	X	X	X	X	X	X	X	X
CSR-U-1	Hard-start Kit	X	X	X	X				
CSR-U-2	Hard-start Kit				X	X			
CSR-U-3	Hard-start Kit						X	X	X
FSK01A	Freeze Protection Kit	X	X	X	X	X	X	X	X
LSK02A	Liquid Line Solenoid Kit	X	X	X	X	X	X	X	X
TXV-30	Fixed TXV Kit	X	X	X					
TXV-42	Fixed TXV Kit				X	X			
TXV-48	Fixed TXV Kit						X		
TXV-60	Fixed TXV Kit							X	X

¹ Installed on indoor coil

² Required for heat pump applications where ambient temperatures fall below 0°F with 50% or higher relative humidity.

ACCESSORIES

ASX/DSX18

Model	Description	A/DSX18 036*	A/DSX18 048*	/DSX18 060*
ABK-20 ¹	Anchor Bracket Kit	X	X	X
ASC01	Anti-Short Cycle Kit	X	X	X
CSR-U-1	Hard-start Kit	X		
CSR-U-2	Hard-start Kit	X		
CSR-U-3	Hard-start Kit		X	X
FSK01A ¹	Freeze Protection Kit	X	X	X
LSK02A	Liquid Line Solenoid Kit	X	X	X
TX2N4A	TXV Kit			
TX3N4	TXV Kit	X		
TX5N4	TXV Kit		X	X

¹ Installed on indoor coil

² Required for heat pump applications where ambient temperatures fall below 0°F with 50% or higher relative humidity.

ACCESSORIES

ASZ13

Model	Description	ASZ13 018	ASZ13 024	ASZ13 030	ASZ13 036	ASZ13 042	ASZ13 048	ASZ13 060
AFE18-60A	All-Fuel Kit	X	X	X	X	X	X	X
ASC01	Anti-Short Cycle Kit	X	X	X	X	X	X	X
CSR-U-1 ⁴	Hard-start Kit	X	X	X	X			
CSR-U-2 ⁴	Hard-start Kit				X	X		
CSR-U-3 ⁴	Hard-start Kit						X	X
FSK01A ²	Freeze Protection Kit	X	X	X	X	X	X	X
LSK02A	Liquid Line Solenoid Kit	X	X	X	X	X	X	X
OT/EHR18-60	Emergency Heat Relay kit	X	X	X	X	X	X	X
OT18-60A ³	Outdoor Thermostat w/Lockout Stat	X	X	X	X	X	X	X
TX2N4A ⁴	TXV Kit	X	X					
TX3N4 ⁴	TXV Kit			X	X			
TX5N4 ⁴	TXV Kit					X	X	X

¹ Contains 20 brackets; four brackets needed to anchor unit to pad

² Installed on indoor coil.

³ Required for heat pump applications where ambient temperatures fall below 0°F with 50% or higher relative humidity.

⁴ Condensing units & heat pumps with reciprocating compressors require the use of start-assist components when used in conjunction with an indoor coil using a non-bleed expansion valve refrigerant metering device.

⁵ Field-installed, non-bleed, expansion valve kit - Condensing units and heat pumps with reciprocating compressors require the use of start-assist components when used in conjunction with an indoor coil using a non-bleed thermal expansion valve refrigerant.

ACCESSORIES

GSZ13

Model	Description	GVSZ13 018	GVSZ13 024	GVSZ13 030	GVSZ13 036	GVSZ13 042	GVSZ13 048	GVSZ13 060
AFE18-60A	All-Fuel Kit	X	X	X	X	X	X	X
ASC01	Anti-Short Cycle Kit	X	X	X	X	X	X	X
CSB-15	Sound Blanket					X	X	X
CSB-16	Sound Blanket	X	X	X	X			
CSR-U-1 ⁴	Hard-start Kit	X	X	X	X			
CSR-U-2 ⁴	Hard-start Kit				X	X		
CSR-U-3 ⁴	Hard-start Kit						X	X
FSK01A ²	Freeze Protection Kit	X	X	X	X	X	X	X
LSK02A	Liquid Line Solenoid Kit	X	X	X	X	X	X	X
OT/EHR18-60	Emergency Heat Relay kit	X	X	X	X	X	X	X
OT18-60A ³	Outdoor Thermostat w/Lockout Stat	X	X	X	X	X	X	X
TX2N4A ⁵	TXV Kit	X	X					
TX3N4 ⁵	TXV Kit			X	X			
TX5N4 ⁵	TXV Kit					X	X	X

GSZ13 Three-Phase

Model	Description	GSZ13 036*	GSZ13 048*	GSZ13 048*	GSZ13 060*	GSZ13 060*
AFE18-60A	All-Fuel Kit	X	X	X	X	X
ASC01	Anti-Short Cycle Kit	X	X	X	X	X
FSK01A ²	Freeze Protection Kit	X	X	X	X	X
LSK02A	Liquid Line Solenoid Kit	X	X	X	X	X
OT/EHR18-60	Emergency Heat Relay kit	X	X	X	X	X
OT18-60A ³	Outdoor Thermostat w/Lockout Stat	X	X	X	X	X
TX3N4 ⁵	TXV Kit	X			X	
TX5N4 ⁵	TXV Kit		X	X		X
CSB-15	Sound Blanket Kit		X	X	X	X
CSB-16	Sound Blanket Kit	X				
LAKT01	Low Ambient Kit	X	X	X	X	X

¹ Contains 20 brackets; four brackets needed to anchor unit to pad

² Installed on indoor coil.

³ Required for heat pump applications where ambient temperatures fall below 0°F with 50% or higher relative humidity.

⁴ Condensing units & heat pumps with reciprocating compressors require the use of start-assist components when used in conjunction with an indoor coil using a non-bleed expansion valve refrigerant metering device.

⁵ Field-installed, non-bleed, expansion valve kit - Condensing units and heat pumps with reciprocating compressors require the use of start-assist components when used in conjunction with an indoor coil using a non-bleed thermal expansion valve refrigerant.

ACCESSORIES

SSZ14

Model	Description	SSZ14 018*	SSZ14 024*	SSZ14 030*	SSZ14 036*	SSZ14 038*	SSZ14 042*	SSZ14 048*	SSZ14 060*
AFE18-60A	All-Fuel Kit	X	X	X	X	X	X	X	X
CSR-U-1	Hard-start Kit	X	X	X	X	X			
CSR-U-2	Hard-start Kit				X	X	X		
CSR-U-3	Hard-start Kit							X	X
FSK01A ¹	Freeze Protection Kit	X	X	X	X	X	X	X	X
LSK02A	Liquid Line Solenoid Kit	X	X	X	X	X	X	X	X
OT18-60A ²	Outdoor Thermostat	X	X	X	X	X	X	X	X
OT/EHR18-60	Emergency Heat Relat Kit	X	X	X	X	X	X	X	X
TX2N4A ³	TXV Kit	X	X						
TX3N4 ³	TXV Kit			X	X	X			
TX5N4 ³	TXV Kit						X	X	X

ASZ14

Model	Description	ASZ14 018*	ASZ14 024*	ASZ14 030*	ASZ14 036*	ASZ14 038*	ASZ14 042*	ASZ14 048*	ASZ14 060*
AFE18-60A	All-Fuel Kit	X	X	X	X	X	X	X	X
CSR-U-1	Hard-start Kit	X	X	X	X	X			
CSR-U-2	Hard-start Kit				X	X	X		
CSR-U-3	Hard-start Kit							X	X
FSK01A ¹	Freeze Protection Kit	X	X	X	X	X	X	X	X
LSK02A	Liquid Line Solenoid Kit	X	X	X	X	X	X	X	X
OT18-60A ²	Outdoor Thermostat	X	X	X	X	X	X	X	X
OT/EHR18-60	Emergency Heat Relat Kit	X	X	X	X	X	X	X	X
TX2N4A ³	TXV Kit	X	X						
TX3N4 ³	TXV Kit			X	X	X			
TX5N4 ³	TXV Kit						X	X	X

GSZ14

Model	Description	GSZ14 018*	GSZ14 024*	GSZ14 030*	GSZ14 036*	GSZ14 042*	GSZ14 048*	GSZ14 060*
AFE18-60A	All-Fuel Kit	X	X	X	X	X	X	X
CSR-U-1	Hard-start Kit	X	X	X	X			
CSR-U-2	Hard-start Kit				X	X		
CSR-U-3	Hard-start Kit						X	X
FSK01A ¹	Freeze Protection Kit	X	X	X	X	X	X	X
LSK02A	Liquid Line Solenoid Kit	X	X	X	X	X	X	X
OT18-60A ²	Outdoor Thermostat	X	X	X	X	X	X	X
OT/EHR18-60	Emergency Heat Relat Kit	X	X	X	X	X	X	X
TX2N4A ³	TXV Kit	X	X					
TX3N4 ³	TXV Kit			X	X			
TX5N4 ³	TXV Kit					X	X	X
CSB-15	Sound Blanket Kit					X	X	X
CSB-16	Sound Blanket Kit	X	X	X	X			

¹ Installed on indoor coil

² Required for heat pump applications where ambient temperatures fall below 0°F with 50% or higher relative humidity.

ACCESSORIES

ASZ16/DSZ16

Model	Description	A/DSZ16 024*	A/DSZ16 030*	A/DSZ16 036*	A/DSZ16 042*	A/DSZ16 048*	A/DSZ16 060*
AFE18-60A	All-Fuel Kit	X	X	X	X	X	X
CSR-U-1	Hard-start Kit	X	X	X			
CSR-U-2	Hard-start Kit			X	X		
CSR-U-3	Hard-start Kit					X	X
FSK01A ¹	Freeze Protection Kit	X	X	X	X	X	X
LSK02A	Liquid Line Solenoid Kit	X	X	X	X	X	X
OT/EHR18-60	Emergency Heat Relay Kit	X	X	X	X	X	X
OT18-60A ²	Outdoor Thermostat w/ Lockout Stat	X	X	X	X	X	X
TX2N4A	TXV Kit	X					
TX3N4	TXV Kit		X	X			
TX5N4	TXV Kit				X	X	X

¹ Installed on indoor coil

² Required for heat pump applications where ambient temperatures fall below 0°F with 50% or higher relative humidity.

SSZ16

Model	Description	SSZ16 024*	SSZ16 030*	SSZ16 036*	SSZ16 042*	SSZ16 048*	SSZ16 060*
AFE18-60A	All-Fuel Kit	X	X	X	X	X	X
CSR-U-1	Hard-start Kit	X	X	X			
CSR-U-2	Hard-start Kit			X	X	X	X
CSR-U-3	Hard-start Kit					X	X
FSK01A ¹	Freeze Protection Kit	X	X	X	X	X	X
LSK02A	Liquid Line Solenoid Kit	X	X	X	X	X	X
OT/EHR18-60	Emergency Heat Relay Kit	X	X	X	X	X	X
OT18-60A ²	Outdoor Thermostat w/ Lockout Stat	X	X	X	X	X	X
TX2N4A	TXV Kit	X					
TX3N4	TXV Kit		X	X			
TX5N4	TXV Kit				X	X	X

¹ Installed on indoor coil

² Required for heat pump applications where ambient temperatures fall below 0°F with 50% or higher relative humidity.

ACCESSORIES

ASZ/DSZ18

Model	Description	A/DSZ18 036*	A/DSZ18 048*	A/DSZ18 060*
AFE18-60A	All-Fuel Kit	X	X	X
CSR-U-1	Hard-start Kit	X		
CSR-U-2	Hard-start Kit	X		
CSR-U-3	Hard-start Kit		X	X
FSK01A ¹	Freeze Protection Kit	X	X	X
LSK02A	Liquid Line Solenoid Kit	X	X	X
OT/EHR18-60	Emergency Heat Relay Kit	X	X	X
OT18-60A ²	Outdoor Thermostat w/ Lockout Stat	X	X	X
TX2N4A ³	TXV Kit			
TX3N4 ³	TXV Kit	X		
TX5N4 ³	TXV Kit		X	X

¹ Installed on indoor coil

² Require for heat pump applications where ambient temperatures fall below 0°F with 50% or higher relative humidity.

³ Field- installed, non- bleed, expansion valve kit —Condensing units and heat pumps with reciprocating compressors require the use of start- assist components when used in conjunction with an indoor coil using a non- bleed thermal expansion valve refrigerant metering device.

ACCESSORIES

EXPANSION VALVE KITS

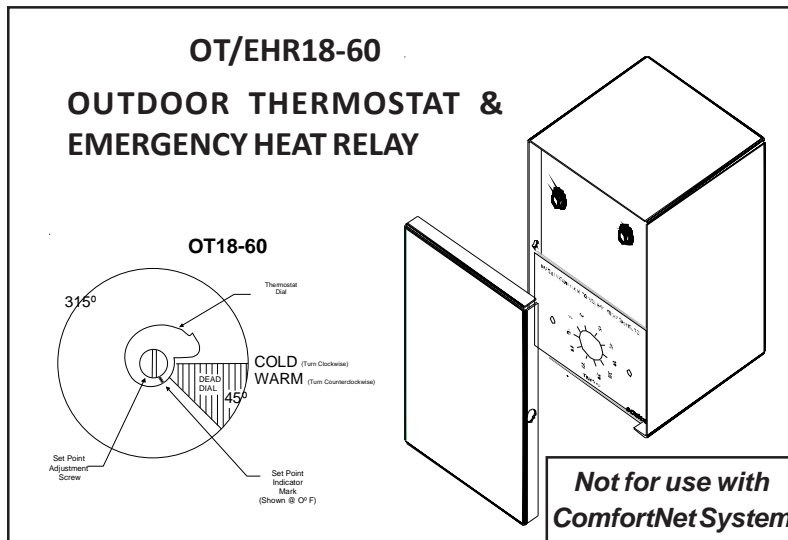
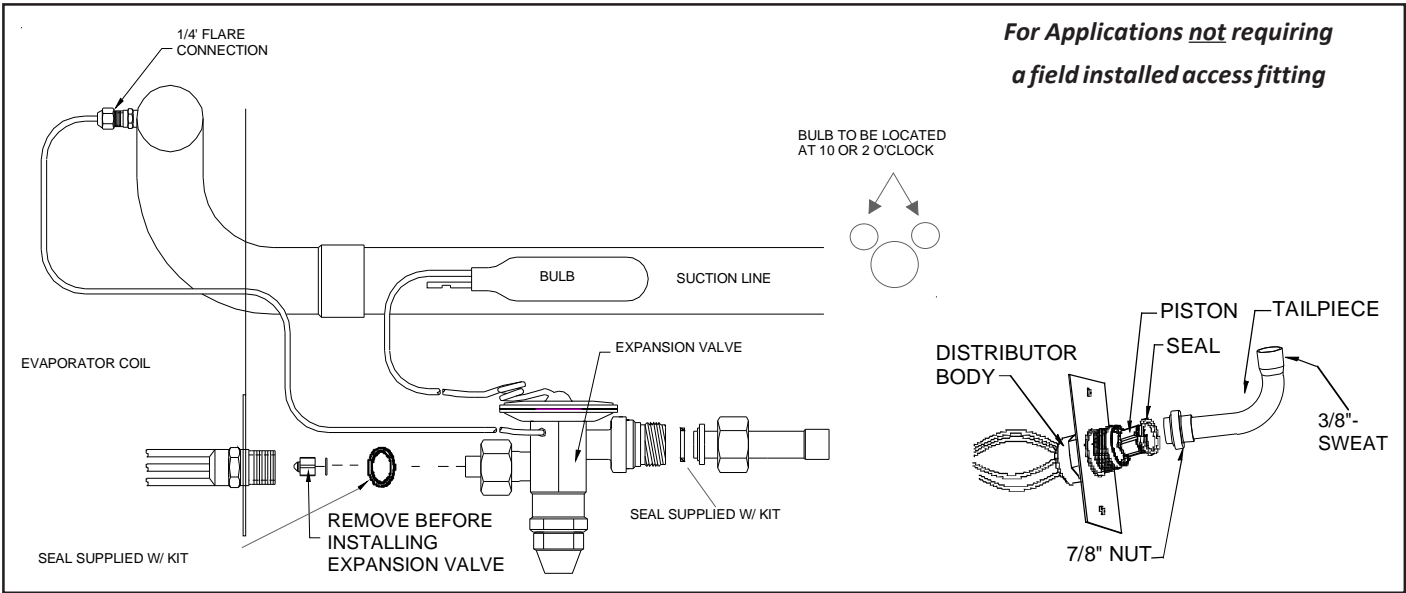
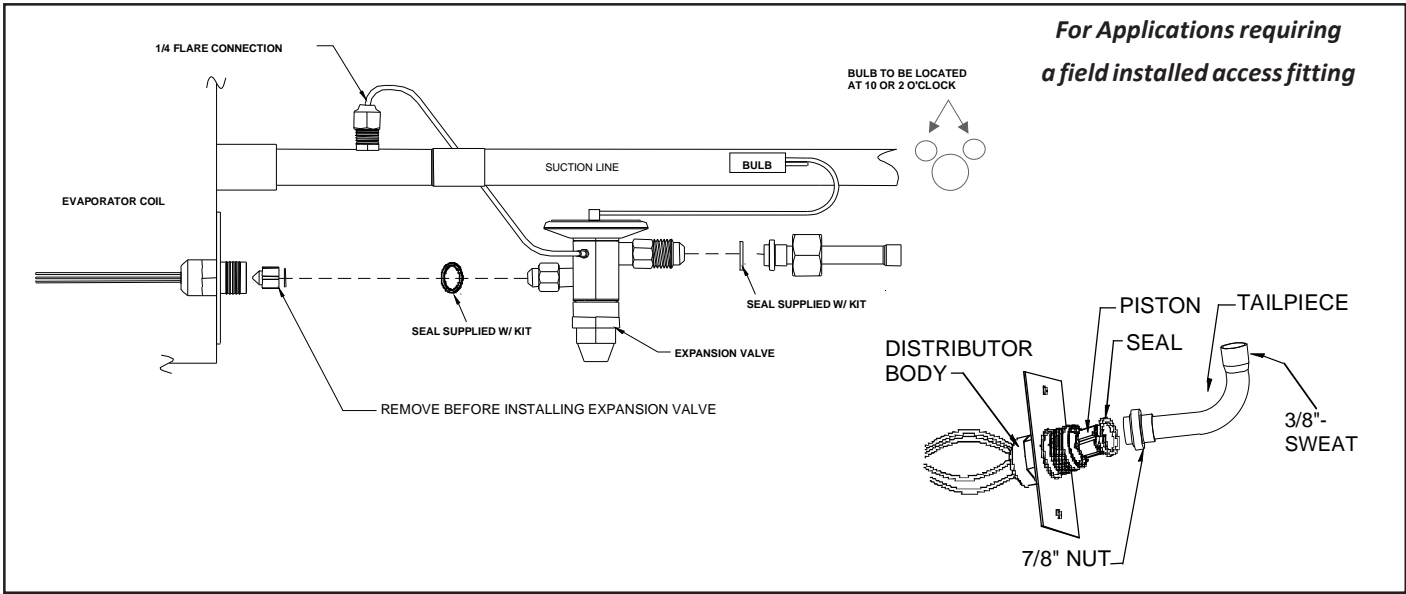

ACCESSORIES

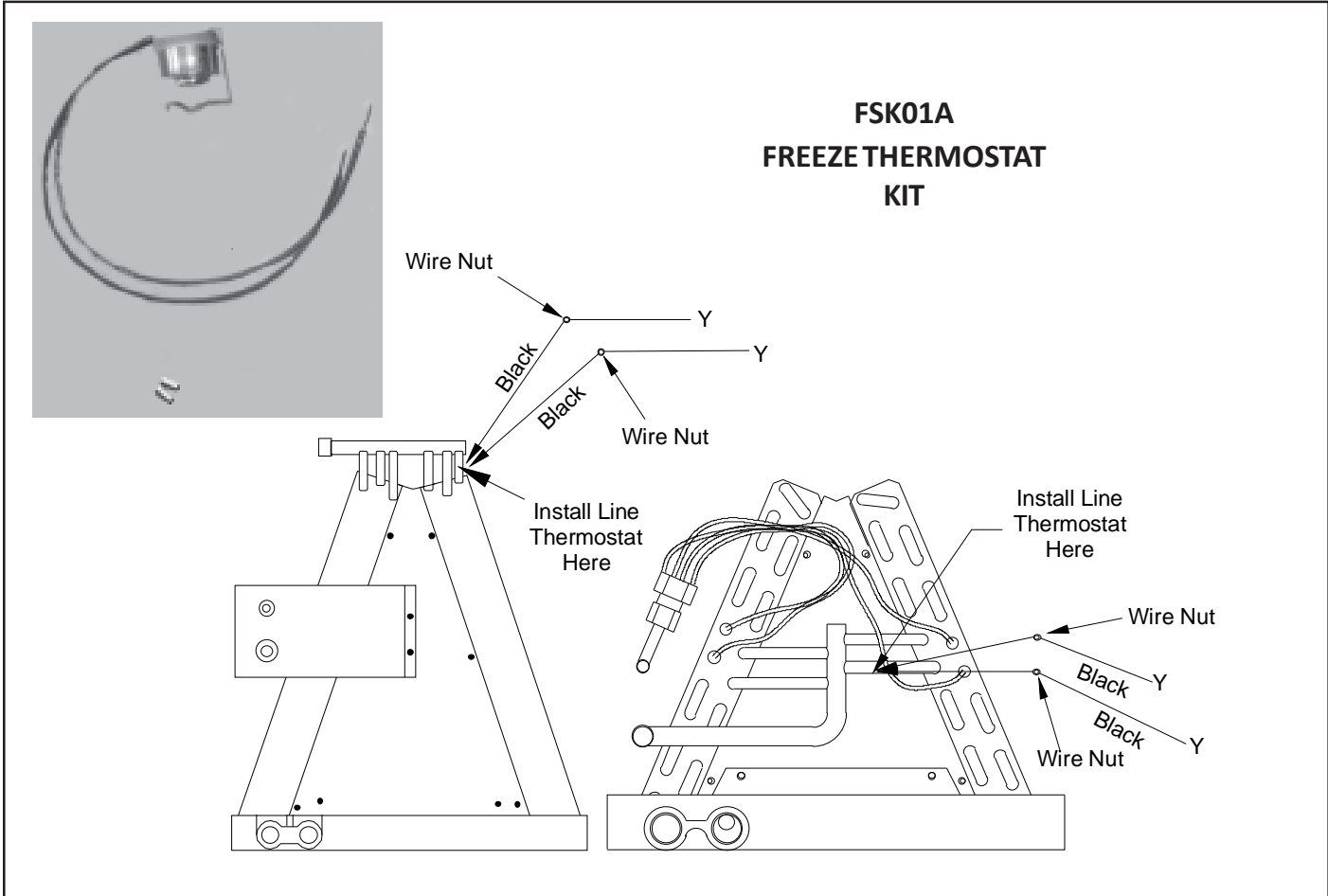

ACCESSORIES

COIL ACCESSORIES

COIL MODEL	TX2N4A TXV KIT	TX3N4 TXV KIT	TX5N4 TXV KIT	FSK01A FREEZE PROTECTION KIT
CA*F18246*	X			X
CA*F30306*		X		X
CA*F31316*				
CA*F36366*				
CA*F36426*		X	X	X
CA*F37436*				
CA*F48606*				
CA*F49616*				
CHPF18246*	X			X
CHPF24306*				
CHPF36366*		X		X
CHPF36426*			X	X
CHPF37436*				
CHPF48606*				
CSCF1824N6*	X			X
CSCF3036N6*		X		X
CSCF3642N6*		X	X	X
CSCF4860N6*				

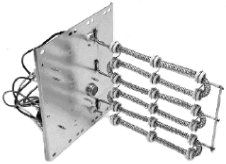

HK* SERIES ELETRIC HEAT KITS - ELECTRIC HEAT KIT APPLICATIONS - MBR, MBE

BLOWER	ELECTRIC HEAT KIT									
	NO HEAT	HKR-03*	HKR05-(C)*	HKR-06*	HKR-08(C)*	HKR-10(C)*	HKA-15C*	HKA-20C*	^HKR3-15*	^HKR3-20A
MBR0800AA-1AA	-	X	X	X	X	X	-	-		
MBR1200AA-1AA	-	X	X	X	X	X	X	X	X	X
MBR1600AA-1AA	-	X	X	X	X	X	X	X	X	X
MBR2000AA-1AA	-	X	X	X	X	X	X	X	X	X
MBE1200AA-1AA	-	-	-	-	X	X	-	-	-	-
MBE1600AA-1AA	-	-	-	-	-	X	-	-	-	-
MBE2000AA-1AA	-	-	-	-	-	X	-	-	-	-
MBE1200AA-1BA	-	X	X	X	X	X	-	-	-	-
MBE1600AA-1BA	-	X	X	X	X	X	-	-	-	-
MBE2000AA-1AA	-	X	X	X	X	X	-	-	-	-

X = Allowable combinations ^ = Circuit 1: Single Phase for Air Handler Motor
 - = Restricted combinations Circuit 2: 3-Phase for HKR3 Heater Kits

ACCESSORIES

ELECTRIC HEAT KIT APPLICATIONS - ARPF

	ARPF1824 1/16	ARPF1931 1/16	ARPF3030 1/16	ARPF3642 1/16	ARPF3743 1/16	ARPF4860 1/16
HKR-03*	X	X	X	X	X	X
HKR-05*, HKR-05C*	X	X	X	X	X	X
HKR-06*	X	X	X	X	X	X
HKR-08*, HKR-08C*	X ¹	X ¹	X	X	X	X
HKR-10*, HKR-10C*	X ¹	X ¹	X ¹	X	X	X
HKA-15C*	X ²	X ²	X ²	X ³	X ³	X
HKA-20C*			X ²	X ³	X ³	X
^ HKR3-15*			X ²	X ³	X ³	X
^ HKR3-20*			X ²	X ³	X ³	X

* Revision level that may or may not be designated

C Circuit breaker option

^ Heat kit required three-phase power supply

¹ Air handler must either be on medium or high speed

² Air handler must be on high speed

³ For static pressure of 0.6 or higher, air handler must be on medium or high speed.

ELECTRIC HEAT KIT APPLICATIONS - ARUF

	ARUF1729 1/16	ARUF1824 1/16	ARUF1931 1/16	ARUF3030 1/16	ARUF3642 1/16	ARUF3743 1/16	ARUF4860 1/16
HKR-03*	X	X	X	X	X	X	X
HKR-05*, HKR-05C*	X	X	X	X	X	X	X
HKR-06*	X	X	X	X	X	X	X
HKR-08*, HKR-08C*	X ¹	X ¹	X ¹	X	X	X	X
HKR-10*, HKR-10C*	X ¹	X ¹	X ¹	X ¹	X	X	X
HKA-15C*	X ²	X ²	X ²	X ²	X ³	X ³	X
HKA-20C*				X ²	X ³	X ³	X
^ HKR3-15*				X ²	X ³	X ³	X
^ HKR3-20*				X ²	X ³	X ³	X

* Revision level that may or may not be designated

C Circuit breaker option

^ Heat kit required three-phase power supply

¹ Air handler must either be on medium or high speed

² Air handler must be on high speed

³ For static pressure of 0.6 or higher, air handler must be on medium or high speed.

ACCESSORIES

ELECTRIC HEAT KIT APPLICATIONS - ADPF

	ADPF182416	ADPF304216	ADPF486016	ADPF4486016
HKR-03*	X	X	X	X
HKR-05*, HKR-05C*	X	X	X	X
HKR-06*	X	X	X	X
HRK-08*, HKR-08C*	X ¹	X ¹	X ¹	X
HKR-10*, HKR-10C*	X ¹	X ¹	X ¹	X
HKA-15C*	X	X	X ²	X ¹
HKA-20C*	-	X	X ²	X ¹
^HKR3-15*	-	X	X	X
^HKR3-20*	-	X	X	X

* Revision level that may or may not be designated

C Circuit Breaker option

^ Heat kit requires 3-phase power supply

¹ Air handler must be on speed tap 2, 3, 4 or 5

² Air handler must be on speed tap 4 or 5

³ Air handler must be on speed tap 3, 4 or 5

ELECTRIC HEAT KIT APPLICATIONS - AEPF

	AEPF183016	AEPF303616	AEPF313716	AEPF426016
HKR-05*, HKR-05C*	X		X	
HRK-08*, HKR-08C	X	X	X	
HKR-10*, HKR-10C	X ¹	X	X	X
HKA-15C*		X ¹	X ¹	X
HKA-20C*				X ²

* Revision level that may or may not be designated

C Circuit Breaker option

¹ This heater kit can be used ONLY for **1000 CFM or higher** applications

² This heater kit can be used ONLY for **1200 CFM or higher** applications

ACCESSORIES

ELECTRIC HEAT KIT APPLICATIONS - ASPF

	ASPF183016	ASPF303616	ASPF313716	ASPF426016
HKR-03*	X	X	X	X
HKR-05*, HKR-05C*	X	X	X	X
HKR-06*	X	X	X	X
HRK-08*, HKR-08C*	X ¹	X ¹	X ¹	X
HKR-10*, HKR-10C*	X ¹	X ¹	X ¹	X
+HKR3-15*	X ²	X ²	X ²	X ¹
+HKR3-20*		X ²	X ²	X ¹
HKA-15C*	X ²	X ²	X ²	X ¹
HKA-20C*		X ²	X ²	X ¹

* Revision level that may or may not be designated

C Circuit Breaker option

+ Heat kit requires 3-phase power supply

¹ Air handler must be on speed tap 2, 3, 4 or 5

² Air handler must be on speed tap 4 or 5

³ Air handler must be on speed tap 3, 4 or 5

DRAIN PAN INSULATION KITS

ARUF14**, ARPT**14**, ASPT**14** & ASUF**14****

MODEL LIST FOR DOWNFLOW KITS

DFK-B Downflow Kit	DFK-C Downflow Kit	DFK-D Downflow Kit
ARUF18B14**	ARUF30C14**	ARUF48D14**
ARUF24B14**	ARUF36C14**	ARUF60D14**
ARUF30B14**	ARUF42C14**	ARPT36D14**
ARPT18B14**	ARPT36C14**	ARPT42D14**
ARPT24B14**	ASPT36C14**	ARPT48D14**
ARPT30B14**	ASPT42C14**	ARPT60D14**
ASPT24B14**	ASPT48C14**	ASPT48D14**
	ASUF49C14**	ASPT60D14**
		ASUF59D14**

ACCESSORIES

ARPT**14**

Heat Kit Applications	ARPT							
	18B14-A*	24B14-A*	30B14-A*	36C14-A*	36D14-A*	42D14-A*	48D14-A*	60D14-A*
HKSX03XC*	X	X	X	X	X	X	X	X
HKSX05XC*	X	X	X	X	X	X	X	X
HKSX06XC*	X	X	X	X	X	X	X	X
HKSX08XC*	X	X	X	X	X	X	X	X
HKSX10XC*	X	X	X	X	X	X	X	X
HKSX15XF*				X	X	X	X	X
HKSX20XF*				X	X	X	X	X
HKSC05XC*	X	X	X	X	X	X	X	X
HKSC08XC*	X	X	X	X	X	X	X	X
HKSC10XC*	X	X	X	X	X	X	X	X
HKSC15XA*			X	X	X	X	X	X
HKSC15XB*			X	X	X	X	X	X
HKSC15XF*				X	X	X	X	X
HKSC19CA*				X				
HKSC19CB*				X				
HKSC20DA*					X	X	X	X
HKSC20DB*					X	X	X	X
HKSC20XF*				X	X	X	X	X

ACCESSORIES

ARUF**14**

Heat Kit Applications	ARUF								
	18B14-A*	24B14-B*	24B14-C*	30B14-A*	30C14-B*	36C14-B*	42C14-A*	48D14-A*	60D14-A*
HKSX03XC*	X	X	X	X	X	X	X	X	X
HKSX05XC*	X	X	X	X	X	X	X	X	X
HKSX06XC*	X	X	X	X	X	X	X	X	X
HKSX08XC*	X	X	X	X	X	X	X	X	X
HKSX10XC*	X	X	X	X	X	X	X	X	X
HKSX15XF*					X	X	X	X	X
HKSX20XF*					X	X	X	X	X
HKSC05XC*	X	X	X	X	X	X	X	X	X
HKSC08XC*	X	X	X	X	X	X	X	X	X
HKSC10XC*	X	X	X	X	X	X	X	X	X
HKSC15XA*				X	X	X	X	X	X
HKSC15XB*				X	X	X	X	X	X
HKSC15XF*					X	X	X	X	X
HKSC19CA*					X	X	X		
HKSC19CB*					X	X	X		
HKSC20DA*								X	X
HKSC20DB*								X	X
HKSC20XF*					X	X	X	X	X
HKSC25DC*							X	X	X

* Revision level that may or may not be designated

Refer to the minimum airflow requirements for each of the heat kits.

*ARUF ARPT	HEATER (kW)								
	3	5	6	8	10	15	19	20	25
18	715	715	715	715	950				
24	715	715	715	715	950				
30B	715	715	715	715	875	875			
30C		1170	1170	1170	1170	1345	1345		
36		1170	1170	1170	1170	1345	1345		
42		1170	1170	1170	1170	1345	1345		
48		1590	1590	1590	1590	1715		1715	1715
60		1590	1590	1590	1590	1715		1715	1715

Minimum CFM required for Heater Kits

ACCESSORIES

ASUF**14**

Heat Kit Applications	ASUF			
	29B14-A*	39C14-A*	49C14-A*	59D14-A*
HKSX03XC*	X	X	X	X
HKSX05XC*	X	X	X	X
HKSX06XC*	X	X	X	X
HKSX08XC*	X	X	X	X
HKSX10XC*	X	X	X	X
HKSX15XF*		X	X	X
HKSX20XF*		X	X	X
HKSC05XC*	X	X	X	X
HKSC08XC*	X	X	X	X
HKSC10XC*	X	X	X	X
HKSC15XA*		X	X	X
HKSC15XB*		X	X	X
HKSC15XF*		X	X	X
HKSC19CA*		X	X	
HKSC19CB*		X	X	
HKSC20DA*				X
HKSC20DB*				X
HKSC20XF*		X	X	X
HKSC25DC*				X

* Revision level that may or may not be designated.

Refer to the minimum airflow requirements for each of the heat kits.

ASUF	HEATER (kW)								
	3	5	6	8	10	15	19	20	25
29	715	715	715	715	875				
39		1170	1170	1170	1170	1345	1345		
49		1170	1170	1170	1170	1345	1345		
59		1590	1590	1590	1590	1715		1715	1715

Minimum CFM required for Heater Kits

ACCESSORIES

ASPT**14**

Heat Kit Applications	ASPT							
	24B14-A*	30C14-A*	36C14-A*	42C14-A*	48C14-A*	42D14-A*	48D14-A*	60D14-A*
HKSX03XC*	X	X	X	X	X	X	X	X
HKSX05XC*	X	X	X	X	X	X	X	X
HKSX06XC*	X	X	X	X	X	X	X	X
HKSX08XC*	X	X	X	X	X	X	X	X
HKSX10XC*	X	X	X	X	X	X	X	X
HKSX15XF*			X	X	X	X	X	X
HKSX20XF*			X	X	X	X	X	X
HKSC05XC*	X	X	X	X	X	X	X	X
HKSC08XC*	X	X	X	X	X	X	X	X
HKSC10XC*	X	X	X	X	X	X	X	X
HKSC15XA*			X	X	X	X	X	X
HKSC15XB*			X	X	X	X	X	X
HKSC15XF*			X	X	X	X	X	X
HKSC19CA*			X	X	X			
HKSC19CB*			X	X	X			
HKSC20DA*						X	X	X
HKSC20DB*						X	X	X
HKSC20XF*			X	X	X	X	X	X
HKSC25DC*							X	X

* Revision level that may or may not be designated.

Refer to the minimum airflow requirements for each of the heat kits.

ASPT	HEATER (kW)								
	3	5	6	8	10	15	19	20	25
ASPT24B14*	715	715	715	715	875	NR	NR	NR	NR
ASPT30C14*	730	715	715	715	950	NR	NR	NR	NR
ASPT36C14*	NR	1170	1170	1170	1170	1345	1345	1345	NR
ASPT42C14*	NR	1170	1170	1170	1170	1345	1345	1345	NR
ASPT48C14*	NR	1170	1170	1170	1170	1345	1345	1345	NR
ASPT42D14*	NR	1590	1590	1590	1590	1715	NR	1715	NR
ASPT48D14*	NR	1590	1590	1590	1590	1715	NR	1715	1715
ASPT60D14*	NR	1590	1590	1590	1590	1715	NR	1715	1715

Minimum CFM required for Heater Kits

ACCESSORIES

AVPTC**14**

Heat Kit Applications	ASPT							
	24B14-A*	30C14-A*	36C14-A*	42C14-A*	48C14-A*	42D14-A*	48D14-A*	60D14-A*
HKSX03XC*	X	X	X	X	X	X	X	X
HKSX05XC*	X	X	X	X	X	X	X	X
HKSX06XC*	X	X	X	X	X	X	X	X
HKSX08XC*	X	X	X	X	X	X	X	X
HKSX10XC*	X	X	X	X	X	X	X	X
HKSX15XF*			X	X	X	X	X	X
HKSX20XF*			X	X	X	X	X	X
HKSC05XC*	X	X	X	X	X	X	X	X
HKSC08XC*	X	X	X	X	X	X	X	X
HKSC10XC*	X	X	X	X	X	X	X	X
HKSC15XA*			X	X	X	X	X	X
HKSC15XB*			X	X	X	X	X	X
HKSC15XF*			X	X	X	X	X	X
HKSC19CA*			X	X	X			
HKSC19CB*			X	X	X			
HKSC20DA*						X	X	X
HKSC20DB*						X	X	X
HKSC20XF*			X	X	X	X	X	X
HKSC25DC*							X	X

* Revision level that may or may not be designated.

Refer to the minimum airflow requirements for each of the heat kits.

Heater Kit (kW)									
	3	5	6	8	10	15	19	20	21 or 25
AVPTC24B14	550	650	700	800	850	NR	NR	NR	NR
AVPTC30C14	600	700	750	875	950	NR	NR	NR	NR
AVPTC36C14	NR	850	900	1000	1200	1440	1500	1500	NR
AVPTC48C14	NR	850	900	1000	1200	1440	1500	1500	NR
AVPTC42D14†	850**	1250	1300	1500	1550	1720	NR	1800	NR
AVPTC48D14††	NR	1250	1300	1500	1550	1720	NR	1815	1850
AVPTC60D14†††	NR	1250	1300	1500	1550	1780	NR	1850	1850

MINIMUM CFM REQUIRED FOR HEATER KITS, See notes below

Note: Airflow data shown applies to the electric heat only in either legacy mode or communicating mode operation

NR - Not rated

* Within thermostat user menu CTK0* communicating thermostat will display 20KW for OFF- OFF- ON dip switch selection, 21kW for

†For match up with a 2 ton outdoor unit: Heater kit application shall not exceed 10 kW.

Airflow for 5 kW up to 10 kW heater kits shall be set to 850 cfm speed tap of ON-ON-ON.

††For match up with a 3 ton outdoor unit: Heater kit application shall not exceed 15 kW.

Airflow for 5 kW up to 15 kW heater kits shall be set to 1300 cfm speed tap of ON-OFF-ON.

†††For match up with a 3.5 ton outdoor unit: Heater kit application shall not exceed 20 kW.

Airflow for 5 kW up to 20 kW heater kits shall be set to 1500 cfm speed tap of ON-OFF-OFF

** 3 kW heater kit is not applicable for this indoor application.

ACCESSORIES

ARUF & ASPT

MODEL LIST FOR DOWNFLOW KIT		
DFK-B DOWNFLOW KIT	DFK-C DOWNFLOW KIT	DFK-D DOWNFLOW KIT
ARUF25B14**	ARUF37C14**	ARUF37D14**
ARUF29B14**	ARUF43C14**	ARUF43D14**
ARUF31B14**	ARUF49C14**	ARUF47D14**
ASPT24B14**	ASPT37C14**	ARUF49D14**
ASPT29B14**	ASPT47C14**	ARUF61D14**
ASPT37B14**	ASPT59C14**	ASPT61D14**
		ASPT47D14**
		ASPT49D14**

MODEL	HEATER KIT (kW)								
	3	5	6	8	10	15	19	20	25
ARUF25B14	715	715	715	715	950				
ARUF29B14	715	715	715	715	950				
ARUF31B14	715	715	715	715	875	875			
ARUF37C14		1170	1170	1170	1170	1345	1345		
ARUF43C14		1170	1170	1170	1170	1345	1345		
ARUF49C14		1170	1170	1170	1170	1340	1430		
ARUF37D14		1170	1170	1170	1170	1345		1345	
ARUF43D14		1170	1170	1170	1170	1345		1345	
ARUF47D14		1170	1170	1170	1170	1345		1345	
ARUF49D14		1240	1240	1240	1240	1520		1520	
ARUF61D14		1590	1590	1590	1590	1715		1715	1715

MINIMUM CFM REQUIRED FOR HEATER KITS

MODEL	HEATER (kW)								
	3	5	6	8	10	15	19	20	25
ASPT24B14	715	715	715	715	850				
ASPT29B14	715	715	715	715	875	1050			
ASPT37B14	715	715	715	715	875	1050			
ASPT37C14		1170	1170	1170	1170	1345	1345		
ASPT47C14		1170	1170	1170	1170	1345	1345		
ASPT59C14		1170	1170	1170	1170	1345	1345		
ASPT47D14		1240	1240	1240	1240	1520		1520	
ASPT49D14		1590	1590	1590	1590	1715		1715	1715
ASPT61D14*		1590	1590	1590	1590	1715		1715	1715

PRODUCT DESIGN

This section gives a basic description of cooling unit operation, its various components and their basic operation. Ensure your system is properly sized for heat gain and loss according to methods of the Air Conditioning Contractors Association (ACCA) or equivalent.

CONDENSING UNIT

The condenser air is pulled through the condenser coil by a direct drive propeller fan. This condenser air is then discharged out of the top of the cabinet. These units are designed for free air discharge, so no additional resistance, like duct work, shall be attached.

The suction and liquid line connections on present models are of the sweat type for field piping with refrigerant type copper. Front seating valves are factory installed to accept the field run copper. The total refrigerant charge for a normal installation is factory installed in the condensing unit.

GSX, GSZ, ASX, ASZ, SSX, SSZ, DSX, DSZ, VSX, and VSZ models are available in 1 1/2 through 5 ton sizes and use R-410A refrigerant. They are designed for 208/230 volt single phase applications.

GSX/GSZ *****3 models are available in 3, 4, and 5 ton sizes and use R-410A refrigerant. They are designed for 208/230 volt 3-phase applications.

ASX, ASZ, DSX and DSZ R-410A model units use the Copeland Scroll "Ultratech" Series compressors which are specifically designed for R-410A refrigerant. These units also have Copeland® ComfortAlert diagnostics.

GSX, GSZ, SSX, SSZ, VSX, and VSZ R-410A model units, except for GSX130181C*, VSX130181B*, VSX130241E*, VSX130421B*, and VSX130481B*, use the Copeland Scroll "Ultratech" Series compressors which are specifically designed for R-410A refrigerant.

There are a number of design characteristics which are different from the traditional reciprocating and/or scroll compressors.

"Ultratech" Series scroll compressors will not have a discharge thermostat. Some of the early model scroll compressors required discharge thermostat.

"Ultratech" Series scroll compressors use "POE" or polyolester oil which is **NOT** compatible with mineral oil based lubricants like 3GS. "POE" oil must be used if additional oil is required.

COILS AND BLOWER COILS

MBR/MBE blower cabinets are designed to be used as a two-piece blower and coil combination. MBR/MBE/MBVC blower sections can be attached to cased evaporator coil. This two-piece arrangement allows for a variety of mix-matching possibilities providing greater flexibility. The MBE/MBVC blower cabinets use a variable speed motor that maintains a constant airflow with a higher duct static.

MBE blower cabinets are approved for applications with cooling coils of up to 0.8 inches W.C. external static pressure. The MBE models includes a feature that allows airflow to be changed by +10% or -15%. The MBVC models allow airflow trimming of +/- 10%.

The MBR blower cabinet uses a PSC motor. It is approved for applications with cooling coils of up to 0.5 inches W.C. external static pressure.

The MBR/MBE blower cabinets with proper coil matches can be positioned for upflow, counterflow, horizontal right or horizontal left operation. All units are constructed with R-4.2 insulation. In areas of extreme humidity (greater than 80% consistently), insulate the exterior of the blower with insulation having a vapor barrier equivalent to ductwork insulation, providing local codes permit.

The CAUF, CAPF and CAPT coils are designed for upflow and counterflow applications. The CACF and CHPF coils are designed for horizontal applications.

AR*F, ASPF, ASUF, ASPT Multi-Position Air Handler

These one-piece multi-position air handlers are used with R-410A and are available in 2 to 5 ton sizes with optional 3 kW to 25kW electric heat kits available for field installation. The AR*F unit's blower design includes a PSC motor and is compatible with heat pumps and cooling applications. ASUF and ASPT units use an EEM blower motor and are compatible with heat pumps and cooling applications.

This appliance can be installed in the vertical or left horizontal position without modification. The horizontal right and downflow positions require product modification. This product is designed for zero inches (0 inches) clearance; however, adequate access for service or replacement must be considered without removing permanent structure. This unit can be installed on a platform when deemed necessary.

In an attic installation a secondary drain pan must be provided by the installer and placed under the entire unit with a separate drain line properly sloped and terminated in an area visible to the owner. This secondary drain pan is required in the event that there is a leak or main drain blockage. Closed cell insulation should be applied to the drain lines in unconditioned spaces where sweating may occur.

NOTE: Single piece air handlers are factory-sealed to achieve a 2% or less leakage rate at 1.0" water gauge external duct static pressure.

PRODUCT DESIGN

The ASX [16 & 18], ASZ [16 & 18], DSX[16 & 18] and DSZ [16 & 18] series split system units use a two-stage scroll compressor. The two-step modulator has an internal unloading mechanism that opens a bypass port in the first compression pocket, effectively reducing the displacement of the scroll. The opening and closing of the bypass port is controlled by an internal electrically operated solenoid.

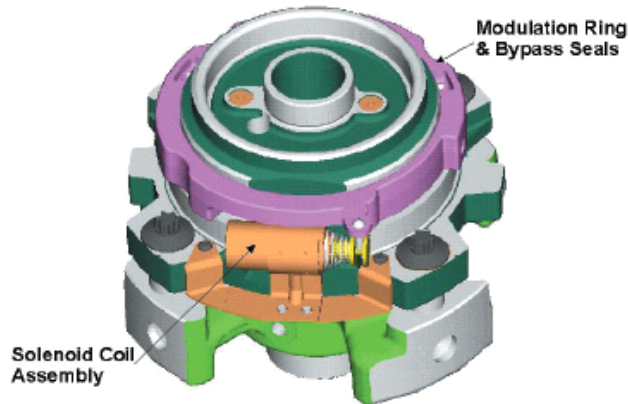

The ZPS/ZRS two-step modulated scroll uses a single step of unloading to go from full capacity to approximately 67% capacity. A single speed, high efficiency motor continues to run while the scroll modulates between the two capacity steps.

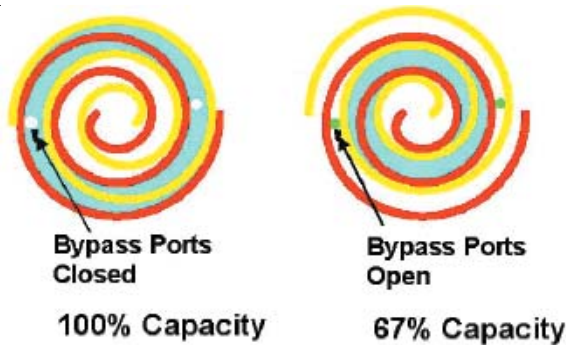

FIGURE A

A scroll is an involute spiral which, when matched with a mating scroll form as shown, generates a series of crescent shaped gas pockets between the two members.

During compression, one scroll remains stationary (fixed scroll) while the other form (orbiting scroll) is allowed to orbit (but not rotate) around the first form.



As this motion occurs, the pockets between the two forms are slowly pushed to the center of the two scrolls while simultaneously being reduced in volume. When the pocket reaches the center of the scroll form, the gas, which is now at a high pressure, is discharged out of a port located at the center.

During compression, several pockets are being compressed simultaneously, resulting in a very smooth process. Both the suction process (outer portion of the scroll members) and the discharge process (inner portion) are continuous.

Some design characteristics of the Compliant Scroll compressor are:

- Compliant Scroll compressors are more tolerant of liquid refrigerant.

NOTE: Even though the compressor section of a Scroll compressor is more tolerant of liquid refrigerant, continued floodback or flooded start conditions may wash oil from the bearing surfaces causing premature bearing failure.

- "Ultratech" Series scroll compressors use "POE" or polyolester oil which is **NOT** compatible with mineral oil based lubricants like 3GS. "POE" oil must be used if additional oil is required.
- Compliant scroll compressors perform "quiet" shutdowns that allow the compressor to restart immediately without the need for a time delay. This compressor will restart even if the system has not equalized.

NOTE: Operating pressures and amp draws may differ from standard reciprocating compressors. This information can be found in the unit's Technical Information Manual.

PRODUCT DESIGN

CAPACITY CONTROL - LEGACY MODELS

During the compression process, there are several pockets within the scroll that are compressing gas. Modulation is achieved by venting a portion of the gas in the first suction pocket back to the low side of the compressor thereby reducing the effective displacement of the compressor. See Figure A. Full capacity is achieved by blocking these vents, increasing the displacement to 100%. A solenoid in the compressor, controlled by an external 24-volt ac signal, moves the slider ring that covers and uncovers these vents. The vent covers are arranged in such a manner that the compressor operates somewhere around 67% capacity when the solenoid is not energized and 100% capacity when the solenoid is energized. The loading and unloading of the two step scroll is done "on the fly" without shutting off the motor between steps. See Figure B below. The unloaded mode default was chosen for two reasons:

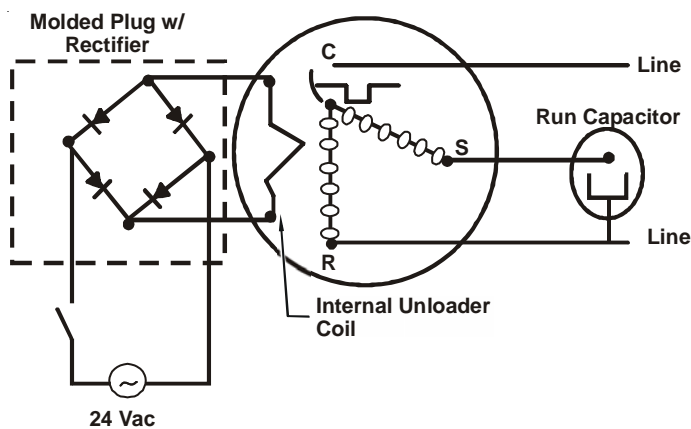

FIGURE B

1. It is expected that the majority of run hours will be in the low capacity, unloaded mode.
2. It allows a simple two-stage thermostat to control capacity through the second stage in both cooling and possibly heating if desired.

UNLOADER SOLENOID

A nominal 24-volt direct current coil activates the internal unloader solenoid. The input control circuit voltage must be 18 to 28 volt ac. The coil power requirement is 20 VA. The external electrical connection is made with a molded plug assembly. This plug is connected to the Comfort Alert™ or CoreSense™ Module (dependent upon which module you are using) which contains a full wave rectifier to supply direct current to the unloader coil.

COOLING

The refrigerant used in the system is R-410A. It is a clear, colorless, non-toxic and non-irritating liquid. R-410A is a 50:50 blend of R-32 and R-125. The boiling point at atmospheric pressure is **-62.9°F**.

A few of the important principles that make the refrigeration cycle possible are: heat always flows from a warmer to a cooler body. Under lower pressure, a refrigerant will absorb heat and vaporize at a low temperature. The vapors may be drawn off and condensed at a higher pressure and temperature to be used again.

The indoor evaporator coil functions to cool and dehumidify the air conditioned spaces through the evaporative process taking place within the coil tubes.

NOTE: The pressures and temperatures shown in the refrigerant cycle illustrations on the following pages are for demonstration purposes only. Actual temperatures and pressures are to be obtained from the "Expanded Performance Chart".

Liquid refrigerant at condensing pressure and temperatures, (270 psig and 122°F), leaves the outdoor condensing coil through the drier and is metered into the indoor coil through the metering device. As the cool, low pressure, saturated refrigerant enters the tubes of the indoor coil, a portion of the liquid immediately vaporizes. It continues to soak up heat and vaporizes as it proceeds through the coil, cooling the indoor coil down to about 48°F.

Heat is continually being transferred to the cool fins and tubes of the indoor evaporator coil by the warm system air. This warming process causes the refrigerant to boil. The heat removed from the air is carried off by the vapor.

As the vapor passes through the last tubes of the coil, it becomes superheated. That is, it absorbs more heat than is necessary to vaporize it. This is assurance that only dry gas will reach the compressor. Liquid reaching the compressor can weaken or break compressor valves.

The compressor increases the pressure of the gas, thus adding more heat, and discharges hot, high pressure superheated gas into the outdoor condenser coil.

In the condenser coil, the hot refrigerant gas, being warmer than the outdoor air, first loses its superheat by heat transferred from the gas through the tubes and fins of the coil. The refrigerant now becomes saturated, part liquid, part vapor and then continues to give up heat until it condenses to a liquid alone. Once the vapor is fully liquefied, it continues to give up heat which subcools the liquid, and it is ready to repeat the cycle.

SYSTEM OPERATION

HEATING

The heating portion of the refrigeration cycle is similar to the cooling cycle. By energizing the reversing valve solenoid coil, the flow of the refrigerant is reversed. The indoor coil now becomes the condenser coil, and the outdoor coil becomes the evaporator coil.

The check valve at the indoor coil will open by the flow of refrigerant letting the now condensed liquid refrigerant bypass the indoor expansion device. The check valve at the outdoor coil will be forced closed by the refrigerant flow, thereby utilizing the outdoor expansion device.

The restrictor orifice used with the CA*F, CHPF and CH**FCB coils will be forced onto a seat when running in the cooling cycle, only allowing liquid refrigerant to pass through the orifice opening. In the heating cycle, it will be forced off the seat allowing liquid to flow around the restrictor. A check valve is not required in this circuit.

COOLING CYCLE

For legacy room thermostat: When the room thermostat calls for cool, the contacts of the room thermostat close making terminals R to Y1 & G (if thermostat calls for low stage cool), or R to Y1, Y2 & G (if thermostat calls for high stage cool), the low voltage circuit of the transformer is completed. Current now flows through the magnetic holding coils of the compressor contactor (CC) and fan relay (RFC). If thermostat calls for high stage cool, the microprocessor on the UC board will also energize the compressor high stage solenoid to run the compressor at full capacity.

This draws in the normally open contact CC, starting the compressor and condenser fan motors in either low or high stage depending on the thermostat's demand. At the same time, contacts RFC close, starting the indoor fan motor.

When the thermostat is satisfied, it opens its contacts, breaking the low voltage circuit, causing the compressor contactor and indoor fan relay to open, shutting down the system.

If the room thermostat fan selector switch should be set on the "on" position, then the indoor blower would run continuously rather than cycling with the compressor.

GSZ, ASZ, SSZ, DSZ, and VSZ models energize the reversing valve thorough the "O" circuit in the room thermostat. Therefore, the reversing valve remains energized as long as the thermostat subbase is in the cooling position. The only exception to this is during defrost.

For heat pumps, during cooling cycle the reversing valve is energized as the room thermostat closes "O" terminal to R and the microprocessor on the UC board responds to such a condition by energizing the solenoid coil on the reversing valve.

DEFROST CYCLE

The defrosting of the outdoor coil is jointly controlled by the defrost control board and the defrost thermostat.

Solid State Defrost Control

During operation the power to the circuit board is controlled by a temperature sensor, which is clamped to a return bend (3/8" coils) or a feeder tube (5 mm coils) entering the outdoor coil. Defrost timing periods of 30, 60, or 90 minutes may be selected by connecting the circuit board jumper to 30, 60, or 90 respectively. Accumulation of time for the timing period selected starts when the sensor closes (approximately 31° F), and when the room thermostat calls for heat. At the end of the timing period, the unit's defrost cycle will be initiated provided the sensor remains closed. When the sensor opens (approximately 75° F), the defrost cycle is terminated and the timing period is reset. If the defrost cycle is not terminated due to the sensor temperature, a ten minute override interrupts the unit's defrost period. The new upgraded defrost control has a 12 minute override interrupt.

HEATING CYCLE

The reversing valve on the GSZ, SSZ, ASZ and DSZ models is energized in the cooling cycle through the "O" terminal on the room thermostat.

These models have a 24 volt reversing valve coil. When the thermostat selector switch is set in the cooling position, the "O" terminal on the thermostat is energized all the time.

Care must be taken when selecting a room thermostat. Refer to the installation instructions shipped with the product for approved thermostats.

When the room thermostat calls for heat, the contacts of the room thermostat close making terminals R to Y & G, the low voltage circuit of the transformer is completed. Current now flows through the magnetic holding coils of the compressor contactor (CC) and fan relay (RFC).

This draws in the normally open contact CC, starting the compressor condenser fan motors. At the same time, contacts RFC close, starting the indoor fan motor.

When the thermostat is satisfied, it opens its contacts, breaking the low voltage circuit, causing the compressor contactor and indoor fan relay to open, shutting down the system.

If the room thermostat fan selector switch should be set to the "on" position, then the indoor blower would run continuously rather than cycling with the compressor.

When the thermostat is satisfied, appropriate commands are sent to the UC control. The compressor relay and outdoor fan relay is de-energized. The compressor high stage solenoid is de-energized if it was energized. The UC control sends an appropriate command to the indoor unit to de-energize the indoor blower motor.

SYSTEM OPERATION

COOLING CYCLE

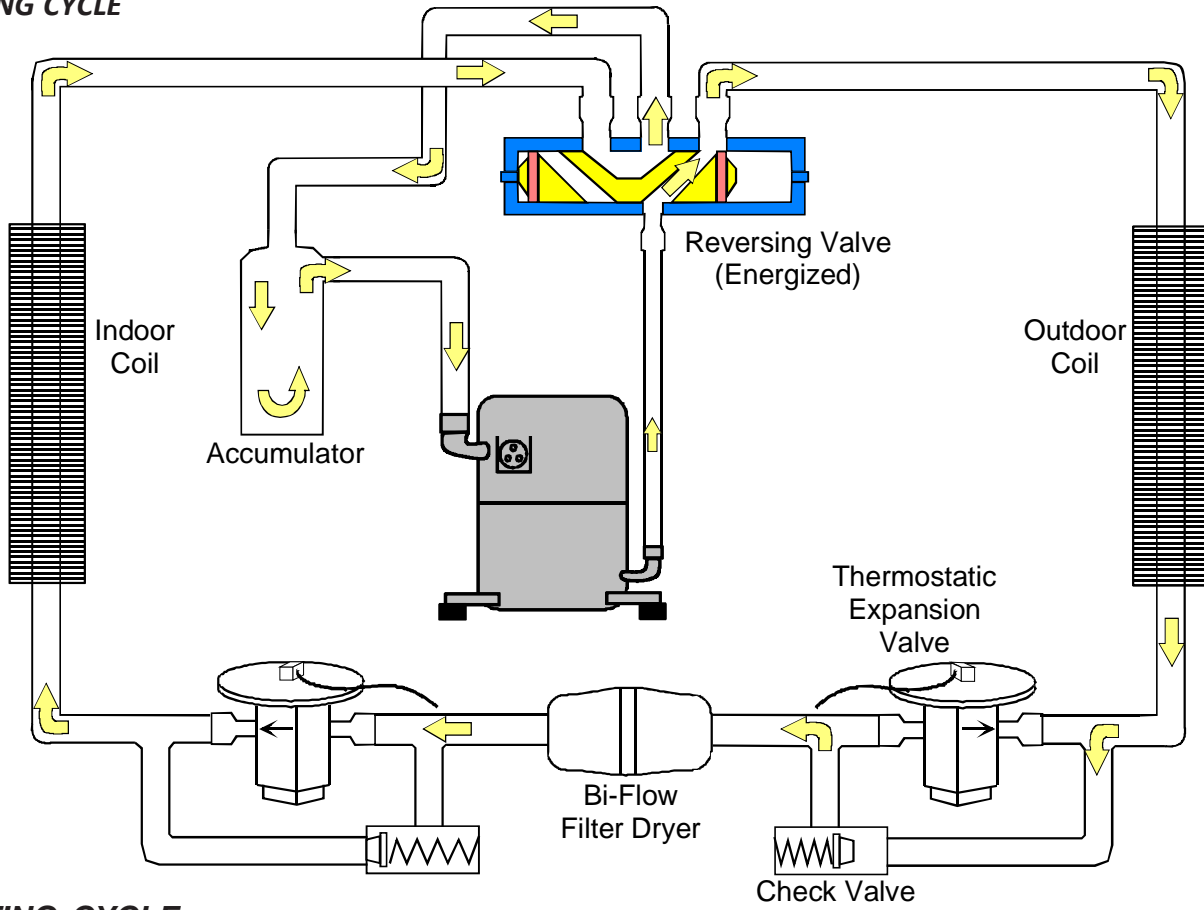

HEATING CYCLE

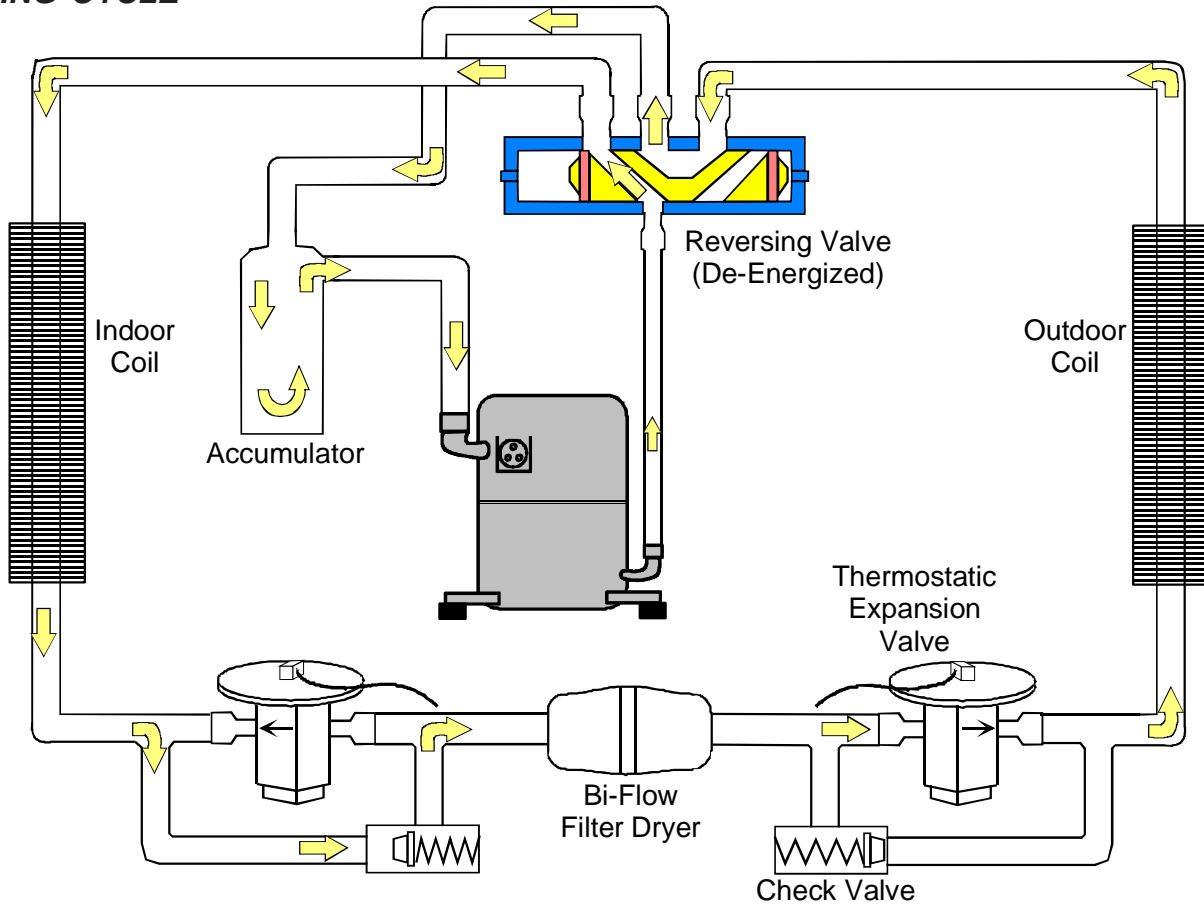

SYSTEM OPERATION

EXPANSION VALVE/CHECK VALVE ASSEMBLY IN COOLING OPERATION

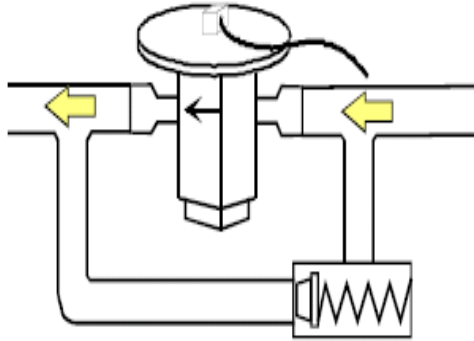

EXPANSION VALVE/CHECK VALVE ASSEMBLY IN HEATING OPERATION

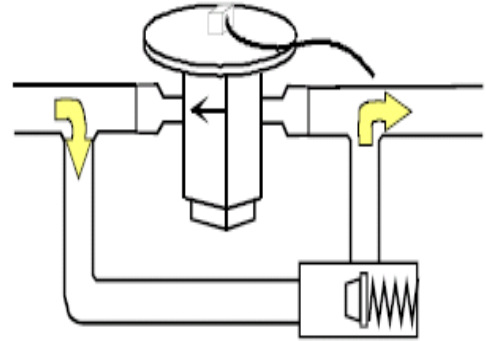

Most expansion valves used in current Amana® Brand Heat Pump products use an internally checked expansion valve. This type of expansion valve does not require an external check valve as shown above. However, the principle of operation is the same.

RESTRICTOR ORIFICE ASSEMBLY IN COOLING OPERATION

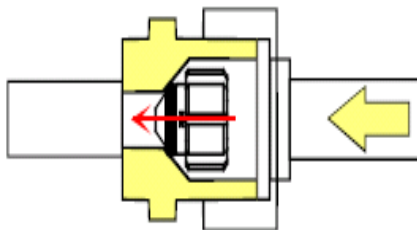

In the cooling mode, the orifice is pushed into its seat, forcing refrigerant to flow through the metered hole in the center of the orifice.

RESTRICTOR ORIFICE ASSEMBLY IN HEATING OPERATION

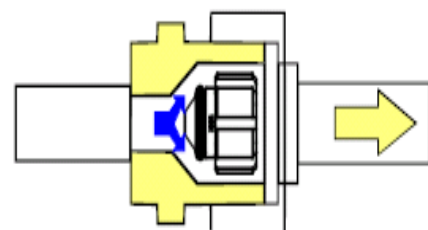

In the heating mode, the orifice moves back off its seat, allowing refrigerant to flow unmetered around the outside of the orifice.

SYSTEM OPERATION

AFE18-60A CONTROL BOARD

DESCRIPTION

The AFE18 control is designed for use in heat pump applications where the indoor coil is located above/downstream of a gas or fossil fuel furnace. It will operate with single and two stage heat pumps and single and two stage furnaces. The AFE18 control will turn the heat pump unit off when the furnace is turned on. An anti-short cycle feature is also incorporated which initiates a 3 minute timed off delay when the compressor goes off. On initial power up or loss and restoration of power, this 3 minute timed off delay will be initiated. The compressor won't be allowed to restart until the 3 minute off delay has expired. Also included is a 5 second de-bounce feature on the "Y, E, W1 and O" thermostat inputs. These thermostat inputs must be present for 5 seconds before the AFE18 control will respond to it.

An optional outdoor thermostat, OT18-60A, can be used with the AFE18 to switch from heat pump operation to furnace operation below a specific ambient temperature setting, i.e. break even temperature during heating. When used in this manner, the "Y" heat demand is switched to the "W1" input to the furnace by the outdoor thermostat and the furnace is used to satisfy the first stage "Y" heat demand. On some controls, if the outdoor thermo-

stat fails closed in this position during the heating season, it will turn on the furnace during the cooling season on a "Y" cooling demand. In this situation, the furnace produces heat and increases the indoor temperature thereby never satisfying the cooling demand. The furnace will continue to operate and can only be stopped by switching the thermostat to the off position or removing power to the unit and then replacing the outdoor thermostat. **When the AFE18 receives a "Y" and "O" input from the indoor thermostat**, it recognizes this as a cooling demand in the cooling mode. If the outdoor thermostat is stuck in the closed position switching the "Y" demand to the "W1" furnace input during the cooling mode as described above, the AFE18 won't allow the furnace to operate. The outdoor thermostat will have to be replaced to restore the unit to normal operation.

⚠ WARNING

HIGH VOLTAGE!
Disconnect ALL power before servicing or installing. Multiple power sources may be present. Failure to do so may cause property damage, personal injury or death.



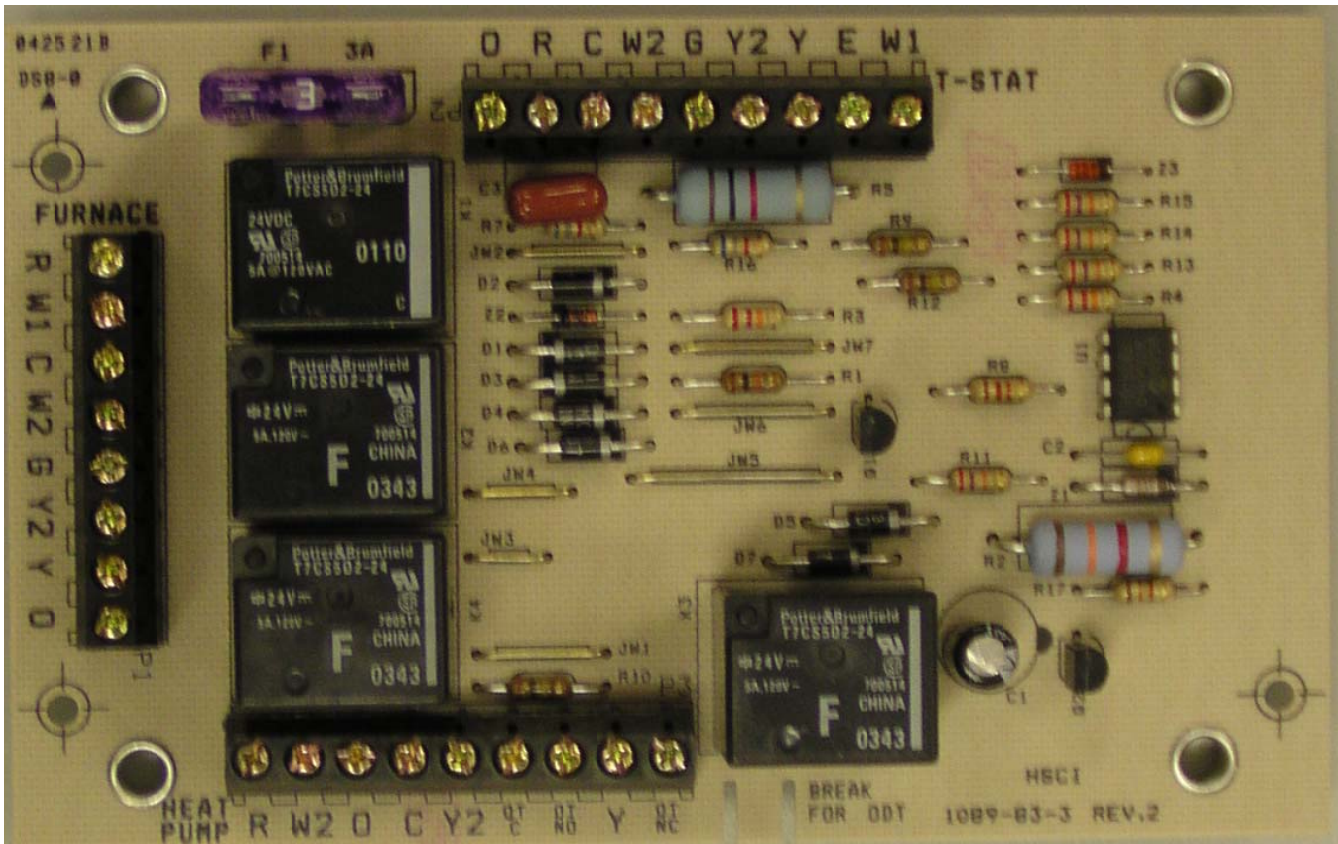

TROUBLESHOOTING CHART

COOLING/HP ANALYSIS CHART

Complaint	No Cooling							Unsatisfactory Cooling/Heating							System Operating Pressures				Test Method Remedy	See Service Procedure Ref.	
	SYMPTOM	System will not start	Compressor will not start - fan runs	Comp. and Cond. Fan will not start	Evaporator fan will not start	Condenser fan will not start	Compressor runs - goes off on overload	Compressor cycles on overload	System runs continuously - little cooling/htg	Too cool and then too warm	Not cool enough on warm days	Certain areas too cool, others too warm	Compressor is noisy	System runs - blows cold air in heating	Unit will not terminate defrost	Unit will not defrost	Low suction pressure	Low head pressure			High suction pressure
Power Failure	●																			Test Voltage	S-1
Blown Fuse	●	●	●																	Inspect Fuse Size & Type	S-1
Unbalanced Power, 3PH		●					●													Test Voltage	S-1
Loose Connection	●			●			●													Inspect Connection - Tighten	S-2, S-3
Shorted or Broken Wires	●	●	●	●	●	●														Test Circuits With Ohmmeter	S-2, S-3
Open Fan Overload					●															Test Continuity of Overload	S-17A
Faulty Thermostat	●		●	●				●												Test Continuity of Thermostat & Wiring	S-3
Faulty Transformer	●	●																		Check Control Circuit with Voltmeter	S-4
Shorted or Open Capacitor		●		●	●	●														Test Capacitor	S-15
Internal Compressor Overload Open		●											◆							Test Continuity of Overload	S-17A
Shorted or Grounded Compressor		●				●														Test Motor Windings	S-17B
Compressor Stuck		●				●							◆							Use Test Cord	S-17D
Faulty Compressor Contactor			●		●	●														Test Continuity of Coil & Contacts	S-7, S-8
Faulty Fan Relay				●																Test Continuity of Coil And Contacts	S-7
Open Control Circuit				●																Test Control Circuit with Voltmeter	S-4
Low Voltage		●				●	●													Test Voltage	S-1
Faulty Evap. Fan Motor				●													●	◆	Repair or Replace	S-16	
Shorted or Grounded Fan Motor					●														●	Test Motor Windings	S-16
Improper Cooling Anticipator							●	●												Check Resistance of Anticipator	S-3B
Shortage of Refrigerant							●	●					◆				●	●		Test For Leaks, Add Refrigerant	S-101,103
Restricted Liquid Line							●	●									●	●	●	Remove Restriction, Replace Restricted Part	S-112
Open Element or Limit on Elec. Heater									◆				◆							Test Heater Element and Controls	S-26,S-27
Dirty Air Filter								●	●	●									◆	Inspect Filter-Clean or Replace	
Dirty Indoor Coil								●	●	●									◆	Inspect Coil - Clean	
Not enough air across Indoor Coil								●	●	●									◆	Check Blower Speed, Duct Static Press, Filter	S-200
Too much air across Indoor Coil																		◆	Reduce Blower Speed	S-200	
Overcharge of Refrigerant						●	●					●	◆						●	Recover Part of Charge	S-113
Dirty Outdoor Coil					●	●			●									◆	●	Inspect Coil - Clean	
Noncondensibles							●		●				◆						●	Recover Charge, Evacuate, Recharge	S-114
Recirculation of Condensing Air							●		●										●	Remove Obstruction to Air Flow	
Infiltration of Outdoor Air							●		●	●										Check Windows, Doors, Vent Fans, Etc.	
Improperly Located Thermostat					●			●		●										Relocate Thermostat	
Air Flow Unbalanced								●	●											Readjust Air Volume Dampers	
System Undersized								●	●											Refigure Cooling Load	
Broken Internal Parts												●	◆							Replace Compressor	S-115
Broken Valves												●						●	●	Test Compressor Efficiency	S-104
Inefficient Compressor													◆						●	Test Compressor Efficiency	S-104
Wrong Type Expansion Valve					●	●	●		●								●	●	◆	Replace Valve	S-110
Expansion Device Restricted					●	●	●		●								●	●	●	Remove Restriction or Replace Expansion Device	S-110
Oversized Expansion Valve							●												●	Replace Valve	
Undersized Expansion Valve					●	●	●		●											Replace Valve	
Expansion Valve Bulb Loose												●								Tighten Bulb Bracket	S-105
Inoperative Expansion Valve					●			●											●	Check Valve Operation	S-110
Loose Hold-down Bolts													●							Tighten Bolts	
Faulty Reversing Valve					●									◆	◆	◆			◆	Replace Valve or Solenoid	S-21, 122
Faulty Defrost Control						●								◆	◆	◆			◆	Test Control	S-24
Faulty Defrost Thermostat														◆	◆	◆			◆	Test Defrost Thermostat	S-25
Flow rator Not Seating Properly								●											●	Check Flow rator & Seat or Replace Flow rator	S-111

● Cooling or Heating Cycle (Heat Pump) ◆ Heating Cycle Only (Heat Pump)

SERVICING

TABLE OF CONTENTS

SERVICING	71	S-18	TESTING CRANKCASE HEATER (OPTIONAL ITEM)	93
S-1 CHECKING VOLTAGE	72	S-21	CHECKING REVERSING VALVE AND SOLENOID	93
S-2 CHECKING WIRING	72	S-24	TESTING DEFROST CONTROL	93
S-3 CHECKING THERMOSTAT AND WIRING	72	S-25	TESTING DEFROST THERMOSTAT	93
S-3A THERMOSTAT WIRING	72	S-50	CHECKING HEATER LIMIT CONTROL(S)	99
S-4 CHECKING TRANSFORMER AND CONTROL CIRCUIT	73	S-52	CHECKING HEATER ELEMENTS	99
S-7 CHECKING CONTACTOR AND/OR RELAYS	73	S-60	ELECTRIC HEATER (OPTIONAL ITEM)	99
S-8 CHECKING CONTACTOR CONTACTS	73	S-61A	CHECKING HEATER LIMIT CONTROL(S)	100
S-9 CHECKING FAN RELAY CONTACTS	74	S-61B	CHECKING HEATER FUSE LINK	100
S-10 MBR/AR*F ELECTRONIC BLOWER TIME DELAY RELAY	75		(OPTIONAL ELECTRIC HEATERS)	100
S-11 CHECKING LOSS OF CHARGE PROTECTOR	75	S-62	CHECKING HEATER ELEMENTS	101
S-12 CHECKING HIGH PRESSURE CONTROL	75	S-100	REFRIGERATION REPAIR PRACTICE	101
S-13 CHECKING LOW PRESSURE CONTROL	75	S-101	LEAK TESTING (NITROGEN OR NITROGEN-TRACED)	101
S-10 COPELAND COMFORT ALERT™	76	S-102	EVACUATION	101
S-10B COPELAND CORESENSE™	76	S-103	CHARGING	102
S-15 CHECKING CAPACITOR	82	S-104	CHECKING COMPRESSOR EFFICIENCY	103
S-15A RESISTANCE CHECK USING A DIGITAL MULTI- METER	82	S-106	OVERFEEDING	104
S-15B CAPACITANCE CHECK USING A DIGITAL MULTI-METER (IN CAPACITANCE MODE)	82	S-107	UNDERFEEDING	104
S-16A CHECKING FAN AND BLOWER MOTOR WINDINGS (PSC MOTORS)	83	S-108	SUPERHEAT	104
S-16B CHECKING FAN AND BLOWER MOTOR (ECM MOTORS)	83	S-109	CHECKING SUBCOOLING	107
S-16C CHECKING ECM MOTOR WINDINGS	84	S-110	CHECKING EXPANSION VALVE OPERATION	107
S-16D ECM CFM ADJUSTMENTS MBE / AEPF	84	S-112	CHECKING RESTRICTED LIQUID LINE	107
S-16E BLOWER PERFORMANCE DATA	88	S-113	OVERCHARGE OF REFRIGERANT	107
S-16F CHECKING HIGH EFFICIENCY MOTORS	88	S-114	NON-CONDENSABLES	108
S-16G EEM BLOWER REPLACEMENT	89	S-115	COMPRESSOR BURNOUT	108
S-17 CHECKING COMPRESSOR	90	S-120	REFRIGERANT PIPING	109
S-17A RESISTANCE TEST	91	S-201	CLEANING ALUMINUM COILS	109
S-17B GROUND TEST	91	S-202	DUCT STATIC PRESSURES AND/OR STATIC PRESSURE DROP ACROSS COILS	109
S-17C UNLOADER TEST PROCEDURE	91	S-203	SINGLE PIECE AIR HANDLER EXTERNAL STATIC	109
S-17D OPERATION TEST	92	S-203A	TWO PIECE AIR HANDLER EXTERNAL STATIC PRESSURE	109
S-17E CHECKING 3-PHASE SCROLL COMPRESSOR ROTATION.....	92	S-204	COIL STATIC PRESSURE DROP	110



WARNING

HIGH VOLTAGE!

Disconnect ALL power before servicing or installing. Multiple power sources may be present. Failure to do so may cause property damage, personal injury or death.



SERVICING

S-1 CHECKING VOLTAGE

1. Remove outer case, control panel cover, etc., from unit being tested.

With power ON:

 **WARNING**
Line Voltage now present.

2. Using a voltmeter, measure the voltage across terminals L1 and L2 of the contactor for the condensing unit or at the field connections for the air handler or heaters.
3. No reading - indicates open wiring, open fuse(s) no power or etc., from unit to fused disconnect service. Repair as needed.
4. With ample voltage at line voltage connectors, energize the unit.
5. Measure the voltage with the unit starting and operating, and determine the unit Locked Rotor Voltage. **NOTE:** If checking heaters, be sure all heating elements are energized.

Locked Rotor Voltage is the actual voltage available at the compressor during starting, locked rotor, or a stalled condition. Measured voltage should be above minimum listed in chart below.

To measure Locked Rotor Voltage attach a voltmeter to the run "R" and common "C" terminals of the compressor, or to the T₁ and T₂ terminals of the contactor. Start the unit and allow the compressor to run for several seconds, then shut down the unit. Immediately attempt to restart the unit while measuring the Locked Rotor Voltage.

6. Locked rotor voltage should read within the voltage tabulation as shown. If the voltage falls below the minimum voltage, check the line wire size. Long runs of undersized wire can cause low voltage. If wire size is adequate, notify the local power company in regard to either low or high voltage.

Unit Supply Voltage		
Voltage	Min.	Max
208/230	197	253
460	414	506

NOTE: When operating electric heaters on voltages other than 240 volts, refer to the System Operation section on electric heaters to calculate temperature rise and air flow. Low voltage may cause insufficient heating.

S-2 CHECKING WIRING

 **WARNING**
HIGH VOLTAGE!
Disconnect ALL power before servicing or installing. Multiple power sources may be present. Failure to do so may cause property damage, personal injury or death.



1. Check wiring visually for signs of overheating, damaged insulation and loose connections.
2. Use an ohmmeter to check continuity of any suspected open wires.
3. If any wires must be replaced, replace with comparable gauge and insulation thickness.

S-3 CHECKING THERMOSTAT AND WIRING

Thermostat Wiring: The maximum wire length for 18 AWG thermostat wire is 100 feet.

S-3A THERMOSTAT WIRING

 **WARNING**
Line Voltage now present.

With power ON, thermostat calling for cooling

1. Use a voltmeter to check for 24 volts at thermostat wires C and Y in the condensing unit control panel.
2. No voltage indicates trouble in the thermostat, wiring or external transformer source.
3. Check the continuity of the thermostat and wiring. Repair or replace as necessary.

Indoor Blower Motor

With power ON:

 **WARNING**
Line Voltage now present.

1. Set fan selector switch at thermostat to "ON" position.
2. With voltmeter, check for 24 volts at wires C and G.
3. No voltage indicates the trouble is in the thermostat or wiring.
4. Check the continuity of the thermostat and wiring. Repair or replace as necessary.

Resistance Heaters

1. Set room thermostat to a higher setting than room temperature so both stages call for heat.
2. With voltmeter, check for 24 volts at each heater relay.

SERVICING

3. No voltage indicates the trouble is in the thermostat or wiring.
4. Check the continuity of the thermostat and wiring. Repair or replace as necessary.

NOTE: Consideration must be given to how the heaters are wired (O.D.T. and etc.). Also safety devices must be checked for continuity.

S-4 CHECKING TRANSFORMER AND CONTROL CIRCUIT

 **WARNING**

HIGH VOLTAGE!
Disconnect ALL power before servicing or installing. Multiple power sources may be present. Failure to do so may cause property damage, personal injury or death.



A step-down transformer (208/240 volt primary to 24 volt secondary) is provided with each indoor unit. This allows ample capacity for use with resistance heaters. The outdoor sections do not contain a transformer (see note below).

 **WARNING**

Disconnect ALL power before servicing.

1. Remove control panel cover, or etc., to gain access to transformer.

With power ON:

 **WARNING**

Line Voltage now present.

2. Using a voltmeter, check voltage across secondary voltage side of transformer (R to C).
3. No voltage indicates faulty transformer, bad wiring, or bad splices.
4. Check transformer primary voltage at incoming line voltage connections and/or splices.
5. If line voltage available at primary voltage side of transformer and wiring and splices good, transformer is inoperative. Replace.

S-7 CHECKING CONTACTOR AND/OR RELAYS

 **WARNING**

HIGH VOLTAGE!
Disconnect ALL power before servicing or installing. Multiple power sources may be present. Failure to do so may cause property damage, personal injury or death.



The compressor contactor and other relay holding coils are wired into the low or line voltage circuits. When the control circuit is energized, the coil pulls in the normally open contacts or opens the normally closed contacts. When the coil is de-energized, springs return the contacts to their normal position.

NOTE: Most single phase contactors break only one side of the line (L1), leaving 115 volts to ground present at most internal components.

NOTE: The compressor contactor/relay in ComfortNet™ ready equipment is fully integrated into the unitary (UC) control. The compressor contactor/relay coil on the UC control is non-serviceable.

1. Remove the leads from the holding coil.
2. Using an ohmmeter, test across the coil terminals.

If the coil does not test continuous, replace the relay or contactor.

S-8 CHECKING CONTACTOR CONTACTS

 **WARNING**

Disconnect ALL power before servicing.

SINGLE PHASE:

1. Disconnect the wire leads from the terminal (T) side of the contactor.
2. With power ON, energize the contactor.

 **WARNING**

Line Voltage now present.

3. Using a voltmeter, test across terminals.
 - A. L2 - T1 - No voltage indicates CC1 contacts open.

If a no voltage reading is obtained - replace the contactor.

SERVICING

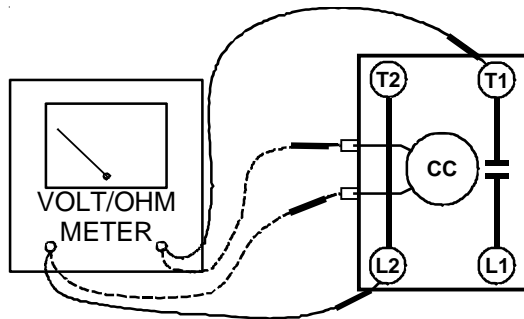

----- Ohmmeter for testing holding coil
 ——— Voltmeter for testing contacts

**TESTING COMPRESSOR CONTACTOR
 (Single Phase)**

THREE PHASE

Using a voltmeter, test across terminals:

- A. L1-L2, L1-L3, and L2-L3 - If voltage is present, proceed to B. If voltage is not present, check breaker or fuses on main power supply..
- B. T1-T2, T1-T3, and T2-T3 - If voltage readings are not the same as in "A", replace contactor.

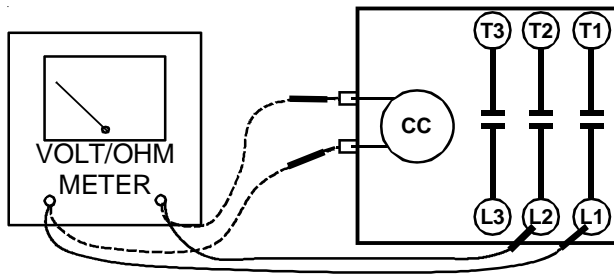

----- Ohmmeter for testing holding coil
 ——— Voltmeter for testing contacts

**TESTING COMPRESSOR CONTACTOR
 (Three-Phase)**

S-9 CHECKING FAN RELAY CONTACTS

⚠ WARNING
HIGH VOLTAGE!
 Disconnect ALL power before servicing or installing. Multiple power sources may be present. Failure to do so may cause property damage, personal injury or death.

1. Disconnect wire leads from terminals 2 and 4 of Fan Relay Cooling and 2 and 4, 5 and 6 of Fan Relay Heating.
2. Using an ohmmeter, test between 2 and 4 - should read open. Test between 5 and 6 - should read continuous.
3. With power ON, energize the relays.

⚠ WARNING
Line Voltage now present.

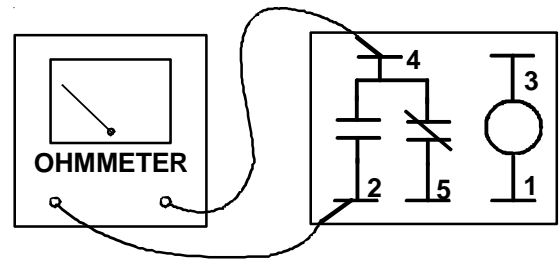

TESTING FAN RELAY

4. Using an ohmmeter, test between 2 and 4 - should read continuous . Test between 5 and 6 - should read open.
5. If not as above, replace the relay.

CHECKING RELAY CONTACTS - PSC FAN MOTOR

⚠ WARNING
HIGH VOLTAGE!
 Disconnect ALL power before servicing or installing. Multiple power sources may be present. Failure to do so may cause property damage, personal injury or death.

1. Disconnect the motor leads from 6-circuit fan motor wire harness.
2. Connect a voltmeter between circuit 3 and circuits 2 (low speed) or 1 (high speed).

NOTE: Circuit 3 is connected directly to L2.

3. Energize the system at low or high stage.

⚠ WARNING
Line Voltage now present.

4. The measured voltage between circuit 3 and circuits 2 or 1 should be approximately 0VAC, which indicates the relay contacts are closed. A voltage measurement of approximately 115VAC indicates the relay is open. Replace the control if the relay checks open when it should be closed. See notes and cautions below.

SERVICING

NOTE: Ensure any ON delays have expired before making voltage measurements

CAUTION: Prolonged operation with the condenser fan motor disconnected will cause the high pressure switch to trip.

S-10 MBR/AR*F ELECTRONIC BLOWER TIME DELAY RELAY

The MBR/AR*F contains an Electronic Blower Time Delay Relay board, B1370735. This board provides on/off time delays for the blower motor in cooling and heat pump heating demands when "G" is energized.

During a cooling or heat pump heating demand, 24Vac is supplied to terminal "G" of the EBTD board to turn on the blower motor. The EBTD initiates a 7 second delay on and then energizes it's onboard relay. The relay on the EBTD board closes it's normally open contacts and supplies power to the blower motor. When the "G" input is removed, the EBTD initiates a 65 second delay off. When the 65 seconds delay expires the onboard relay is de-energized and it's contacts open and remove power from the blower motor.

During an electric heat only demand, "W1" is energized but "G" is not. The blower motor is connected to the normally closed contacts of the relay on the EBTD board. The other side of this set of contacts is connected to the heat sequencer on the heater assembly that provides power to the first heater element. When "W1" is energized, the sequencer will close it's contacts within 10 to 20 seconds to supply power to the first heater element and to the blower motor through the normally closed contacts on the relay on the EBTD. When the "W1" demand is removed, the sequencer opens it contacts within 30 to 70 seconds and removes power from the heater element and the blower motor.

The EBTD also contains a speedup terminal to reduce the delays during troubleshooting of the unit. When this terminal is shorted to the common terminal, "C", on the EBTD board, the delay ON time is reduced to 3 seconds and the delay OFF time is reduced to 5 second.

Two additional terminals, M1 and M2, are on the EBTD board. These terminals are used to connect the unused leads from the blower motor and have no affect on the board's operation.

S-11 CHECKING LOSS OF CHARGE PROTECTOR

(Heat Pump Models)

The loss of charge protector senses the pressure in the liquid line and will open its contacts on a drop in pressure. the low pressure control will automatically reset itself with a rise in pressure.

The low pressure control is designed to cut-out (open) at approximately 21 PSIG. It will automatically cut-in (close) at approximately 50 PSIG. Test for continuity using a VOM and if not as above, replace the control.

S-12 CHECKING HIGH PRESSURE CONTROL

WARNING

HIGH VOLTAGE!
Disconnect ALL power before servicing or installing. Multiple power sources may be present. Failure to do so may cause property damage, personal injury or death.



The high pressure control capillary senses the pressure in the compressor discharge line. If abnormally high condensing pressures develop, the contacts of the control open, breaking the control circuit before the compressor motor overloads. This control is automatically reset.

1. Using an ohmmeter, check across terminals of high pressure control, with wire removed. If not continuous, the contacts are open.
2. Attach a gauge to the dill valve port on the base valve.

With power ON:

WARNING

Line Voltage now present.

3. Start the system and place a piece of cardboard in front of the condenser coil, raising the condensing pressure.
4. Check pressure at which the high pressure control cuts-out. If it cuts-out at 610 PSIG \pm 10 PSIG, it is operating normally (See causes for high head pressure in Service Problem Analysis Guide). If it cuts out below this pressure range, replace the control.

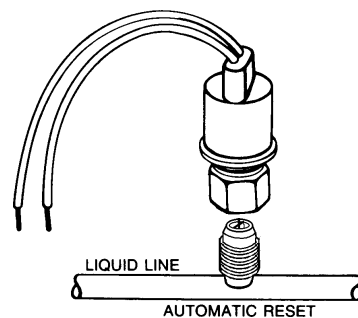

S-13 CHECKING LOW PRESSURE CONTROL

The low pressure control senses the pressure in the suction line and will open its contacts on a drop in pressure. The low pressure control will automatically reset itself with a rise in pressure.

The low pressure control is designed to cut-out (open) at approximately 21 PSIG for heat pumps and 55 PSIG for air conditioners. It will automatically cut-in (close) at approximately 50 PSIG for heat pumps and 95 PSIG for air conditioners.

Test for continuity using a VOM and if not as above, replace the control.

SERVICING

S-10 COPELAND COMFORT ALERT™

DIAGNOSTICS - 3-WIRE MODULE

Applies to ASX /ASZ and DSX/DSZ units

⚠ WARNING

HIGH VOLTAGE
 Disconnect ALL power before servicing or installing this unit. Multiple power sources may be present. Failure to do so may cause property damage, personal injury or death.



Comfort Alert™ is self-contained with no required external sensors and is designed to install directly into the electrical box of any residential condensing unit that has a Copeland Scroll™ compressor inside.

Once attached, Comfort Alert provides around-the-clock monitoring for common electrical problems, compressor defects and broad system faults. If a glitch is detected, an LED indicator flashes the proper alert codes to help you quickly pinpoint the problem. *See Diagnostic Table: 3-Wire Comfort Alert Module on previous page.*

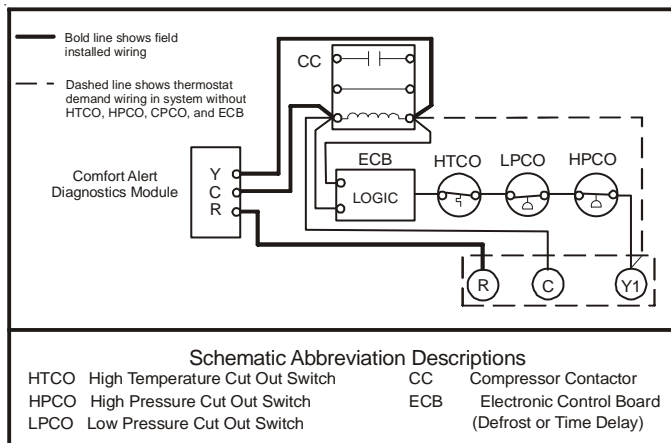

Wiring Schematic - 3-Wire Comfort Alert Module

Green power LED indicates voltage is present at the power connection of the module.

Yellow alert LED flashes to indicate fault code.

Red trip LED indicates if compressor is tripped or has no power.



S-10B COPELAND CORESENSE™

DIAGNOSTICS - 3-WIRE MODULE

Applies to ASX /ASZ and DSX/DSZ units

⚠ WARNING

HIGH VOLTAGE!
 Disconnect ALL power before servicing or installing. Multiple power sources may be present. Failure to do so may cause property damage, personal injury or death.



The CoreSense™ module is self-contained with no required external sensors and works with any residential condensing unit that has a Copeland Scroll™ compressor inside.

Once attached, CoreSense™ provides around-the-clock monitoring for common electrical problems, compressor defects and broad system faults. If a glitch is detected, an LED indicator flashes the proper alert codes to help you quickly pinpoint the problem. *See Diagnostic Table: 3-Wire CoreSense™ Module on following pages.*

SERVICING

DIAGNOSTICS TABLE: 2-WIRE COMFORT ALERT™ MODULE

Status LED	Status LED Description	Status LED Troubleshooting Information
Green “POWER”	Module has power	Supply voltage is present at module terminals
Red “TRIP”	Thermostat demand signal Y1 is present, but the compressor is not running	<ol style="list-style-type: none"> 1. Compressor protector is open 2. Outdoor unit power disconnect is open 3. Compressor circuit breaker or fuse(s) is open 4. Broken wire or connector is not making contact 5. Low pressure switch open if present in system 6. Compressor contactor has failed open
Yellow “ALERT” Flash Code 1	Long Run Time Compressor is running extremely long run cycles	<ol style="list-style-type: none"> 1. Low refrigerant charge 2. Evaporator blower is not running 3. Evaporator coil is frozen 4. Faulty metering device 5. Condenser coil is dirty 6. Liquid line restriction (filter drier blocked if present in system) 7. Thermostat is malfunctioning
Yellow “ALERT” Flash Code 2	System Pressure Trip Discharge or suction pressure out of limits or compressor overloaded	<ol style="list-style-type: none"> 1. High head pressure 2. Condenser coil poor air circulation (dirty, blocked, damaged) 3. Condenser fan is not running 4. Return air duct has substantial leakage 5. If low pressure switch present in system, check Flash Code 1 information
Yellow “ALERT” Flash Code 3	Short Cycling Compressor is running only briefly	<ol style="list-style-type: none"> 1. Thermostat demand signal is intermittent 2. Time delay relay or control board defective 3. If high pressure switch present go to Flash Code 2 information 4. If low pressure switch present go to Flash Code 1 information
Yellow “ALERT” Flash Code 4	Locked Rotor	<ol style="list-style-type: none"> 1. Run capacitor has failed 2. Low line voltage (contact utility if voltage at disconnect is low) 3. Excessive liquid refrigerant in compressor 4. Compressor bearings are seized
Yellow “ALERT” Flash Code 5	Open Circuit	<ol style="list-style-type: none"> 1. Outdoor unit power disconnect is open 2. Compressor circuit breaker or fuse(s) is open 3. Compressor contactor has failed open 4. High pressure switch is open and requires manual reset 5. Open circuit in compressor supply wiring or connections 6. Unusually long compressor protector reset time due to extreme ambient temperature 7. Compressor windings are damaged
Yellow “ALERT” Flash Code 6	Open Start Circuit Current only in run circuit	<ol style="list-style-type: none"> 1. Run capacitor has failed 2. Open circuit in compressor start wiring or connections 3. Compressor start winding is damaged
Yellow “ALERT” Flash Code 7	Open Run Circuit Current only in start circuit	<ol style="list-style-type: none"> 1. Open circuit in compressor run wiring or connections 2. Compressor run winding is damaged
Yellow “ALERT” Flash Code 9	Low Voltage Control circuit < 17VAC	<ol style="list-style-type: none"> 1. Control circuit transformer is overloaded 2. Low line voltage (contact utility if voltage at disconnect is low)

- FLASH CODE NUMBER CORRESPONDS TO A NUMBER OF LED FLASHES, FOLLOWED BY A PAUSE AND THEN REPEATED
- TRIP AND ALERT LEDS FLASHING AT SAME TIME MEANS CONTROL CIRCUIT VOLTAGE IS TOO LOW FOR OPERATION.
- LAST ALERT FLASH CODE IS DISPLAYED FOR 1 MINUTE AFTER MODULE IS POWERED ON.

SERVICING

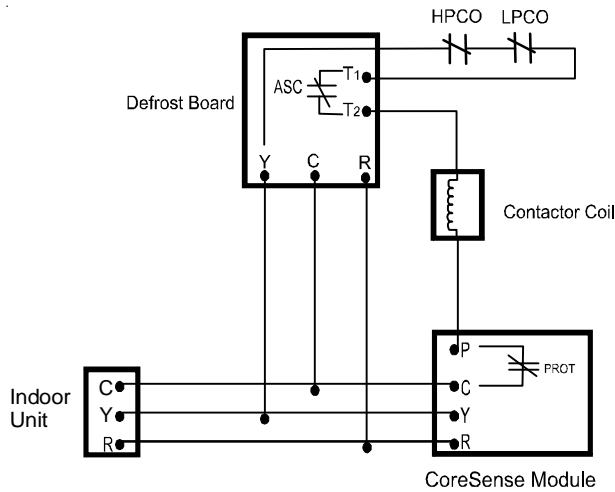

Schematic Abbreviation Descriptions

HTCO	High Temperature Cut Out Switch	CC	Compressor Contactor
HPCO	High Pressure Cut Out Switch	ECB	Electronic Control Board (Defrost or Time Delay)
LPCO	Low Pressure Cut Out Switch		

Wiring Schematic - 3-Wire CoreSense™ Alert Module

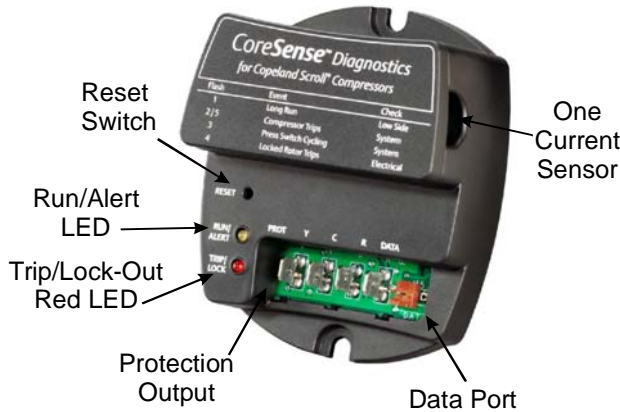

DIAGNOSTICS - 2-WIRE MODULE

Applies to ASX130[18-60]CA, ASX140[18-36]1CA, ASX140421DA, and ASX140[48-60]1BA units

⚠ WARNING

HIGH VOLTAGE!
Disconnect ALL power before servicing or installing. Multiple power sources may be present. Failure to do so may cause property damage, personal injury or death.

The CoreSense™ module is self-contained with no required external sensors and works with any residential condensing unit that has a Copeland Scroll™ compressor inside.

Once attached, CoreSense™ provides around-the-clock monitoring for common electrical problems, compressor defects and broad system faults. If a glitch is detected, an LED indicator flashes the proper alert codes to help you quickly pinpoint the problem. See *Diagnostic Table: 2-Wire Comfort Alert™ Module* on following pages.)

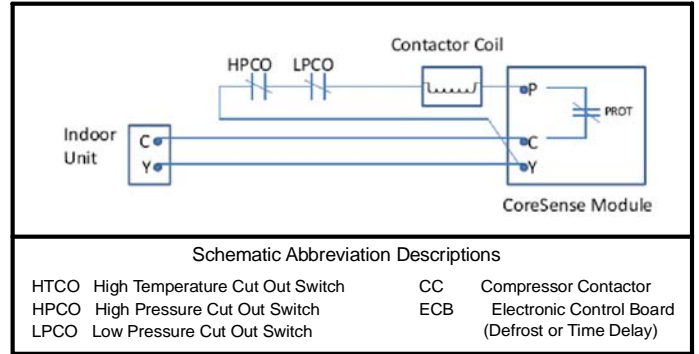

Wiring Schematic - 2-Wire CoreSense™ Module

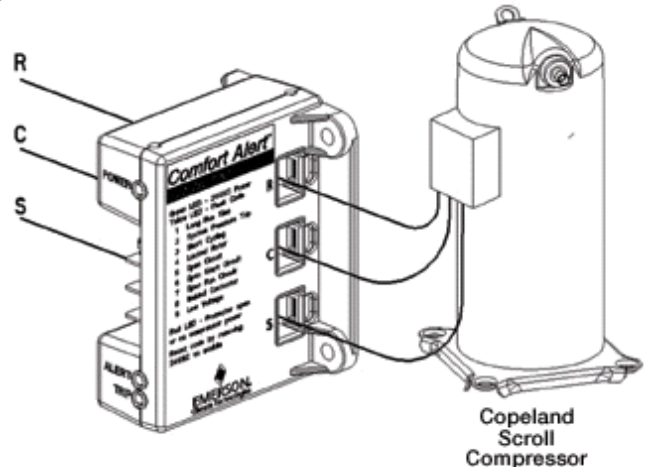

SERVICING

DIAGNOSTICS TABLE: CORESENSE™ MODULE

Flash code number corresponds to the number of LED flashes, followed by a pause and then repeated.

TRIP and ALERT LEDs flashing at the same time mean control circuit voltage is too low for operation.

Status	Description	Troubleshooting Information
Solid Yellow "RUN"	Module has power and operating normally	Supply voltage is present at module terminals
Solid Red "TRIP"	Thermostat demand signal Y is present, but the compressor is not running	<ol style="list-style-type: none"> Compressor protector is open <ul style="list-style-type: none"> Check for high head pressure Check compressor supply voltage Outdoor unit power disconnect is open Compressor circuit breaker or fuse(s) is open Broken wire or connector is not making contact High pressure switch open if present in system Compressor contactor has failed open
"ALERT" Flash Codes		
Yellow "ALERT" Flash Code 1	Long Run Time; Compressor is running extremely long run cycles indicative of low capacity due to a system low-side fault	<ol style="list-style-type: none"> Low refrigerant charge Evaporator blower is not running <ul style="list-style-type: none"> Check blower relay coil and contacts Check blower motor capacitor Check blower motor for failure or blockage Check evaporator blower wiring and connectors Check indoor blower control board Check thermostat wiring for open circuit Evaporator coil is frozen <ul style="list-style-type: none"> Check for low suction pressure Check for excessively low thermostat setting Check evaporator airflow (coil blockages or return air filter) Check ductwork or registers for blockage Faulty metering device <ul style="list-style-type: none"> Check TXV bulb installation (size, location and contact) Check if TXV/fixe orifice is stuck closed or defective Liquid line restriction (filter drier blocked if present in system) Thermostat is malfunctioning <ul style="list-style-type: none"> Check thermostat sub-base or wiring for short circuit Check thermostat installation (location, level)
Yellow "ALERT" Flash Code 2	Compressor (Pressure) Trip; Discharge pressure out of limits or compressor overloaded	<ol style="list-style-type: none"> Condenser fan is not running <ul style="list-style-type: none"> Check fan capacitor Check fan wiring and connectors Check fan motor for failure or blockage High head pressure <ul style="list-style-type: none"> Check high pressure switch if present in system Check if system is overcharged with refrigerant Check for non-condensable in system Condenser coil poor air circulation (dirty, blocked, damaged)
Yellow "ALERT" Flash Code 3	Short Cycling; Compressor is running only briefly	<ol style="list-style-type: none"> Thermostat demand signal is intermittent Time delay relay or control board defective Low or high pressure switch is cycling

SERVICING

DIAGNOSTICS TABLE: CORESENSE™ MODULE (CONT.)

Flash code number corresponds to the number of LED flashes, followed by a pause and then repeated.

TRIP and ALERT LEDs flashing at the same time mean control circuit voltage is too low for operation.

Status	Description	Troubleshooting Information
Yellow "ALERT" Flash Code 4	Locked Rotor	<ol style="list-style-type: none"> 1. Run capacitor has failed 2. Low line voltage (contact utility if voltage at disconnect is low) <ul style="list-style-type: none"> • Check wiring connections 3. Excessive liquid refrigerant in compressor 4. Compressor bearings are seized <ul style="list-style-type: none"> • Measure compressor oil level
Yellow "ALERT" Flash Code 5	Compressor (Moderate Run) Trip	<ol style="list-style-type: none"> 1. Evaporator blower is not running <ul style="list-style-type: none"> • Check blower relay coil and contacts • Check blower motor capacitor • Check blower motor for failure or blockage • Check evaporator blower wiring and connectors • Check indoor blower control board • Check thermostat wiring for open circuit 2. Faulty metering device <ul style="list-style-type: none"> • Check TXV bulb installation (size, location and contact) • Check if TXV/fixed orifice is stuck closed or defective 3. Condenser coil poor air circulation (dirty, blocked, damaged) 4. Low refrigerant charge
"LOCK" Flash Codes		
Red "LOCK" Flash Code 2 Yellow Off	Compressor (Pressure) Trip; Compressor is locked out after 4 consecutive or 10 total compressor (pressure) trip events	<ol style="list-style-type: none"> 1. Condenser fan is not running <ul style="list-style-type: none"> • Check fan capacitor • Check fan wiring and connectors • Check fan motor for failure or blockage 2. High head pressure <ul style="list-style-type: none"> • Check high pressure switch if present in system • Check if system is overcharged with refrigerant • Check for non-condensable in system 3. Condenser coil poor air circulation (dirty, blocked, damaged)
Red "LOCK" Flash Code 3 Yellow Off	Short Cycling; Compressor is locked out after 10 consecutive short cycling events	<ol style="list-style-type: none"> 1. Thermostat demand signal is intermittent 2. Time delay relay or control board defective 3. If high pressure switch present go to Flash Code 2 information
Red "LOCK" Flash Code 4 Yellow Off	Locked Rotor; Compressor is locked out after 10 consecutive locked rotor events	<ol style="list-style-type: none"> 1. Run capacitor has failed 2. Low line voltage (contact utility if voltage at disconnect is low) <ul style="list-style-type: none"> • Check wiring connections 3. Excessive liquid refrigerant in compressor 4. Compressor bearings are seized <ul style="list-style-type: none"> • Measure compressor oil level
Red "LOCK" Flash Code 5 Yellow Off	Compressor (Moderate Run) Trip; Compressor is locked out after 4 consecutive or 10 total compressor (moderate run) trip events	<ol style="list-style-type: none"> 1. Evaporator blower is not running <ul style="list-style-type: none"> • Check blower relay coil and contacts • Check blower motor capacitor • Check blower motor for failure or blockage • Check evaporator blower wiring and connectors • Check indoor blower control board • Check thermostat wiring for open circuit 2. Faulty metering device <ul style="list-style-type: none"> • Check TXV bulb installation (size, location and contact) • Check if TXV/fixed orifice is stuck closed or defective 3. Condenser coil poor air circulation (dirty, blocked, damaged) 4. Low refrigerant charge

SERVICING

Table 1 - Quick Reference Table

Alert Code	Alert Condition	Lock Level	Lock Indication
Normal Run Solid Yellow	Normal operation, no trip.	N/A	N/A
Code1 Yellow Flash 1	Long run time. Compressor is on running for more than 18 hours. (Code1 is disabled in Heat Pump mode.)	N/A	N/A
Code2 Yellow Flash 2	Compressor (pressure) trip. Compressor runs for 12 sec to 15 min followed by a compressor trip condition lasting longer than 7 min.	4x consecutive	Red: Flash 2 Yellow: Off
Code3 Yellow Flash 3	Pressure switch cycling. Compressor runs for 12 sec to 15 min followed by a compressor trip lasting between 35 sec to 7 min.	4x consecutive or 10x total	Red: Flash 3 Yellow: Off
Code4 Yellow Flash 4	Locked rotor. Compressor trips within a compressor run time of 12 sec and does not start within 35 sec.	10x consecutive	Red: Flash 4 Yellow: Off
Code5 Yellow Flash 5	Compressor (moderate run) trip. Compressor runs for 15 min to 18 hrs followed by a compressor trip lasting longer than 7 min.	4x consecutive or 10x total	Red: Flash 5 Yellow: Off
Code9 Red Flash 9	The current to the PROT terminal is greater than 2A	Current >2A for 40ms	Red: Flash 9 Yellow: Off
Trip Solid Red	Demand is present, but compressor is not running	N/A	N/A

SERVICING

S-15 CHECKING CAPACITOR

CAPACITOR, RUN

A run capacitor is wired across the auxiliary and main windings of a single phase permanent split capacitor motor. The capacitor's primary function is to reduce the line current while greatly improving the torque characteristics of a motor. This is accomplished by using the 90° phase relationship between the capacitor current and voltage in conjunction with the motor windings, so that the motor will give two phase operation when connected to a single phase circuit. The capacitor also reduces the line current to the motor by improving the power factor.

The line side of this capacitor is marked with "COM" and is wired to the line side of the circuit.

CAPACITOR, START

SCROLL COMPRESSOR MODELS

In most cases hard start components are not required on Scroll compressor equipped units due to a non-replaceable check valve located in the discharge line of the compressor. However, in installations that encounter low lock rotor voltage, a hard start kit can improve starting characteristics and reduce light dimming within the home. Only hard start kits approved by Amana® brand or Copeland should be used. "Kick Start" and/or "Super Boost" kits are not approved start assist devices.

The discharge check valve closes off high side pressure to the compressor after shut down allowing equalization through the scroll flanks. Equalization requires only about 1/2 second.

To prevent the compressor from short cycling, a Time Delay Relay (Cycle Protector) has been added to the low voltage circuit.

S-15A RESISTANCE CHECK USING A DIGITAL MULTI-METER

⚠ WARNING

HIGH VOLTAGE!
Disconnect ALL power before servicing or installing. Multiple power sources may be present. Failure to do so may cause property damage, personal injury or death.



Check for Digital Test

1. Set the meter on Ohm range (Set it at least 1000 Ohm =1k).

⚠ WARNING

Discharge capacitor through a 20 to 30 OHM resistor before handling.

2. Connect the Meter leads to the Capacitor terminals.
3. Digital meter will show a reading momentarily (Figure 1). Note the reading.

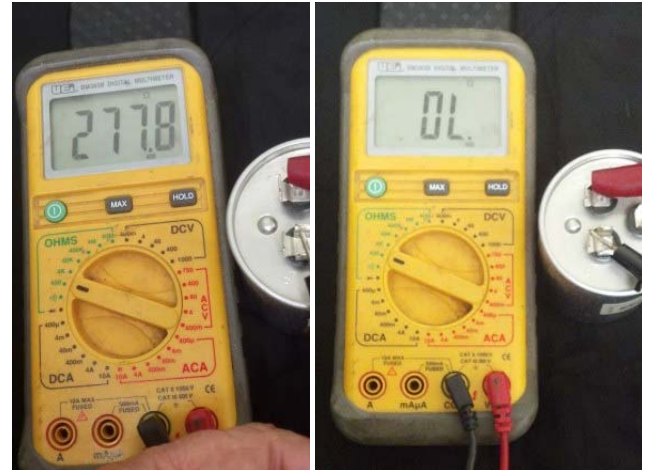

Figure 1

Figure 2

4. Reading will immediately return to the OL = (Open Line) (Figure 2). Every attempt of Step 2 will show the same result as was in step 4 and Step 5. This indicates that the capacitor is good.
5. If there is no Change, then capacitor is dead and must be replaced.

Check for Analog Meter

- A. Good Condition - indicator swings to zero and slowly returns to infinity. (Start capacitor with bleed resistor will not return to infinity. It will still read the resistance of the resistor).
- B. Shorted - indicator swings to zero and stops there - replace.
- C. Open - no reading - replace. (Start capacitor would read resistor resistance.)

S-15B CAPACITANCE CHECK USING A DIGITAL MULTI-METER (IN CAPACITANCE MODE)

⚠ WARNING

Discharge capacitor through a 20 to 30 OHM resistor before handling.

NOTE: You can do this test with a multi-meter if you have a Capacitance meter on your multi-meter.

1. Remove the capacitor from the circuit.
2. Now Select "Capacitance" on your multi-meter.
3. Now connect the capacitor terminals to the multi-meter leads.
4. If the reading is near to the actual value of the capacitor (i.e. the printed value on the capacitor). The capacitor is good. (Note that the reading may be less than the actual printed value of the capacitor).
5. If you read a significantly lower capacitance or none at all, then capacitor is dead and must be replaced.

SERVICING

S-16A CHECKING FAN AND BLOWER MOTOR WINDINGS (PSC MOTORS)

The auto reset fan motor overload is designed to protect the motor against high temperature and high amperage conditions by breaking the common circuit within the motor, similar to the compressor internal overload. However, heat generated within the motor is faster to dissipate than the compressor, allow at least 45 minutes for the overload to reset, then retest.



WARNING
HIGH VOLTAGE!
 Disconnect ALL power before servicing or installing. Multiple power sources may be present. Failure to do so may cause property damage, personal injury or death.

1. Remove the motor leads from its respective connection points and capacitor (if applicable).
2. Check the continuity between each of the motor leads.
3. Touch one probe of the ohmmeter to the motor frame (ground) and the other probe in turn to each lead.

If the windings do not test continuous or a reading is obtained from lead to ground, replace the motor.

S-16B CHECKING FAN AND BLOWER MOTOR (ECM MOTORS)

An ECM is an *Electronically Commutated Motor* which offers many significant advantages over PSC motors. The ECM has near zero rotor loss, synchronous machine operation, variable speed, low noise, and programmable air flow. Because of the sophisticated electronics within the ECM motor, some technicians are intimidated by the ECM motor; however, these fears are unfounded. GE offers two ECM motor testers, and with a VOM meter, one can easily perform basic troubleshooting on ECM motors. An ECM motor requires power (line voltage) and a signal (24 volts) to operate. The ECM motor stator contains permanent magnet. As a result, the shaft feels "rough" when turned by hand. This is a characteristic of the motor, not an indication of defective bearings.



WARNING
Line Voltage now present.

1. Disconnect the 5-pin connector from the motor.
2. Using a volt meter, check for line voltage at terminals #4 & #5 at the power connector. If no voltage is present:
3. Check the unit for incoming power See section S-1.
4. Check the control board, See section S-40.

5. If line voltage is present, reinsert the 5-pin connector and remove the 16-pin connector.
6. Check for signal (24 volts) at the transformer.
7. Check for signal (24 volts) from the thermostat to the "G" terminal at the 16-pin connector.
8. Using an ohmmeter, check for continuity from the #1 & #3 (common pins) to the transformer neutral or "C" thermostat terminal. If you do not have continuity, the motor may function erratically. Trace the common circuits, locate and repair the open neutral.
9. Set the thermostat to "Fan-On". Using a voltmeter, check for 24 volts between pin # 15 (G) and common.
10. Disconnect power to compressor. Set thermostat to call for cooling. Using a voltmeter, check for 24 volts at pin # 6 and/or #14.
11. Set the thermostat to a call for heating. Using a voltmeter, check for 24 volts at pin #2 and/or #11.

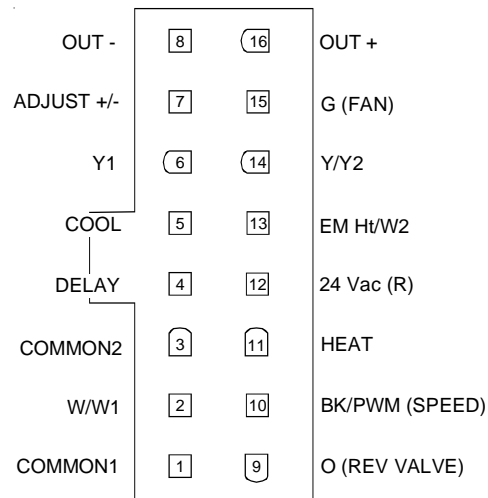
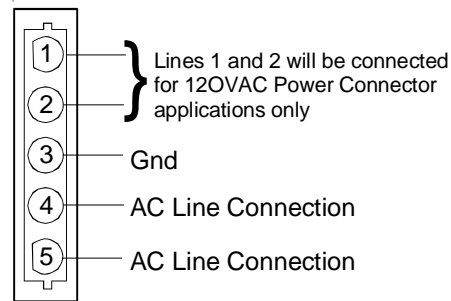

16-PIN ECM HARNESS CONNECTOR

If you do not read voltage and continuity as described, the problem is in the control or interface board, but not the motor. If you register voltage as described, the ECM power head is defective and must be replaced.

SERVICING

S-16C CHECKING ECM MOTOR WINDINGS

WARNING

HIGH VOLTAGE!
Disconnect ALL power before servicing or installing. Multiple power sources may be present. Failure to do so may cause property damage, personal injury or death.

1. Disconnect the 5-pin and the 16-pin connectors from the ECM power head.
2. Remove the 2 screws securing the ECM power head and separate it from the motor.
3. Disconnect the 3-pin motor connector from the power head and lay it aside.
4. Using an ohmmeter, check the motor windings for continuity to ground (pins to motor shell). If the ohmmeter indicates continuity to ground, the motor is defective and must be replaced.
5. Using an ohmmeter, check the windings for continuity (pin to pin). If no continuity is indicated, the thermal limit (over load) device may be open. Allow motor to cool and retest.

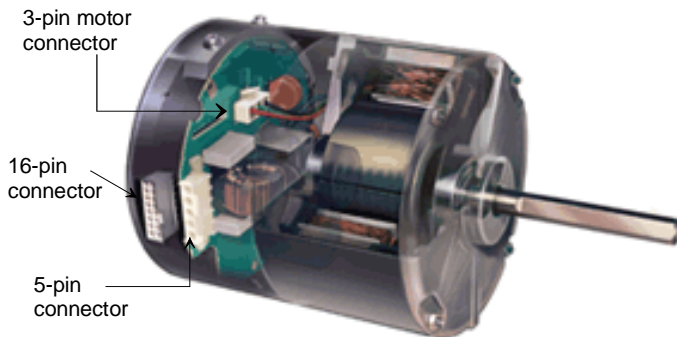

S-16DECM CFM ADJUSTMENTS MBE / AEPF

MBE MOTOR

This section references the operation characteristics of the MBE/AEPF models motor only. The ECM control board is factory set with the dipswitch #4 in the "ON" position and all other dipswitches are factory set in the "OFF" position. When MBE/AEPF are used with 2-stage cooling units, dipswitch #4 should be in the "OFF" position.

For most applications, the settings are to be changed according to the electric heat size and the outdoor unit selection.

The MBE/AEPF products use a General Electric ECM™ motor. This motor provides many features not available on the traditional PSC motor. These features include:

- Improved Efficiency
- Constant CFM
- Soft Start and Stop
- Improved Humidity Control

MOTOR SPEED ADJUSTMENT

Each ECM™ blower motor has been preprogrammed for operation at 4 distinct airflow levels when operating in Cooling/Heat Pump mode or Electric Heat mode. These 4 distinct levels may also be adjusted slightly lower or higher if desired. The adjustment between levels and the trim adjustments are made by changing the dipswitch(s) either to an "OFF" or "ON" position.

DIPSWITCH FUNCTIONS

The MBE/AEPF air handler motors have an electronic control that contains an eight (8) position dip switch. The function of these dipswitches are shown in **Table 1**.

Dipswitch Number	Function
1	Electric Heat
2	
3	N/A
4	Indoor Thermostat
5	Cooling & Heat Pump CFM
6	
7	CFM Trim Adjust
8	

Table 1

CFM DELIVERY

Tables 2, 3, 5 and 6 show the CFM output for dipswitch combinations 1-2, and 5-6.

Model	Switch 1	Switch 2	CFM
MBE1200	OFF	OFF	1,200
	ON	OFF	1,000
	OFF	ON	800
	ON	ON	600
MBE1600	OFF	OFF	1,600
	ON	OFF	1,400
	OFF	ON	1,200
	ON	ON	1,000
MBE2000	OFF	OFF	2,000
	ON	OFF	1,800
	OFF	ON	1,600
	ON	ON	1,200

Table 2

SERVICING

Cooling/Heat Pump Operation

Model	Switch 5	Switch 6	CFM
MBE1200	OFF	OFF	1,200
	ON	OFF	1,000
	OFF	ON	800
	ON	ON	600
MBE1600	OFF	OFF	1,600
	ON	OFF	1,400
	OFF	ON	1,200
	ON	ON	1,000
MBE2000	OFF	OFF	2,000
	ON	OFF	1,800
	OFF	ON	1,600
	ON	ON	1,200

Table 3

THERMOSTAT “FAN ONLY” MODE

During Fan Only Operations, the CFM output is 30% of the cooling setting.

Dipswitch Functions

The AEPF air handler motor has an electronic control that contains an eight (8) position dip switch. The function of these dipswitches are shown in **Table 9**.

Dipswitch Number	Function
1	Electric Heat
2	
3	N/A
4	Indoor Thermostat
5	Cooling & Heat Pump CFM
6	
7	CFM Trim Adjust
8	

Table 9

CFM Delivery

Tables 10-Electric Heat and 11-Cooling/Heat Pump show the CFM output for dipswitch combinations 1-2, and 5-6.

Model	Switch		Switch		Emergecnry (Electric) Heat	Heat Pump w/Backup Heat
	1	2	7	8		
AEPF1830	OFF	OFF	OFF	OFF	1100	1210
	ON	OFF	OFF	OFF	890	935
	OFF	ON	OFF	OFF	700	770
AEPF3036	OFF	OFF	OFF	OFF	2050	2150
	ON	OFF	OFF	OFF	1750	1835
AEPF3137	OFF	ON	OFF	OFF	1600	1680
AEPF4260	ON	ON	OFF	OFF	1200	1260
	ON	ON	OFF	ON	1020	1070

Table 10

Model	Switch		Switch		Nominal Cooling Tonnage	CFM
	5	6	7	8		
AEPF1830	OFF	OFF	OFF	OFF	2 ½	1100
	ON	OFF	OFF	OFF	2	800
	OFF	ON	OFF	OFF	1 ½	600
AEPF3036	OFF	OFF	OFF	OFF	5	1800
	ON	OFF	OFF	OFF	4	1580
AEPF3137	OFF	ON	OFF	OFF	3 ½	1480
AEPF4260	ON	ON	OFF	OFF	3	1200
	ON	ON	OFF	ON	2 ½	1020

Table 11

Thermostat “Fan Only Mode”

During “Fan Only Mode” operation, the CFM output is 30% of the cooling setting.

CFM Trim Adjust

Minor adjustments can be made through the dip switch combination of 7-8. The following **Table 12** shows the switch position for this feature.

CFM	Switch 7	Switch 8
+10%	ON	OFF
-15%	OFF	ON

Humidity Control

When using a Humidistat (normally closed), cut jumper PJ6 on the control board. The Humidistat will only affect cooling airflow by adjusting the Airflow to 85%.

SERVICING

Troubleshooting Chart for GE/Regal-Beloit ECM Variable Speed Air Circulator Blower Motors

Symptom	Fault Description(s)	Possible Causes	Corrective Action	Cautions and Notes
- Motor rocks slightly when starting.	- This is normal start-up for variable speed motor.	----	----	----
- No movement.	- Manual disconnect switch off or door switch open. - Blow n fuse or circuit breaker. - 24 Vac wires miswired. - Unseated pins in wiring harness connectors. - Bad motor/control module. - Moisture present in motor or control module.	<ul style="list-style-type: none"> - Check 230 Vac power at motor. - Check low voltage (24 Vac R to C) at motor. - Check low voltage connections (G, Y, W, R, C) at motor. - Check for unseated pins in connectors on motor harness. - Test with a temporary jumper between R - G. 	<ul style="list-style-type: none"> - Turn power OFF prior to repair. - Wait 5 minutes after disconnecting power before opening motor. - Handle electronic motor/control with care. 	
- Motor won't start.	- Loose motor mount. - Blower wheel not tight on motor shaft. - Bad motor/control module.	<ul style="list-style-type: none"> - Check for loose motor mount. - Make sure blower wheel is tight on shaft. - Perform motor/control replacement check, ECM motors only. 	<ul style="list-style-type: none"> - Turn power OFF prior to repair. - Wait 5 minutes after disconnecting power before opening motor. - Handle electronic motor/control with care. 	
- Motor oscillates up & down while being tested off of blower.	- It is normal for motor to oscillate with no load on shaft.	----	----	----
- Motor starts, but runs erratically.	- Variation in 230 Vac to motor. - Unseated pins in wiring harness connectors. - Erratic CFM command from "BK" terminal. - Improper thermostat connection or setting. - Moisture present in motor/control module.	<ul style="list-style-type: none"> - Check line voltage for variation or "sag". - Check low voltage connections (G, Y, W, R, C) at motor, unseated pins in motor harness connectors. - Check-out system controls - Thermostat. - Perform Moisture Check.* 	<ul style="list-style-type: none"> - Turn power OFF prior to repair. 	
	- "Hunts" or "puffs" at high CFM (speed).	- Incorrect or dirty filter(s). - Incorrect supply or return ductwork. - Incorrect blower speed setting.	<ul style="list-style-type: none"> - Does removing panel or filter reduce "puffing"? - Check/replace filter. - Check/correct duct restrictions. - Adjust to correct blower speed setting. 	<ul style="list-style-type: none"> - Turn power OFF prior to repair.

*Moisture Check

- Connectors are oriented "down" (or as recommended by equipment manufacturer).
- Is condensate drain plugged?
- Check for unenergized condensation.

Note: You must use the correct replacement control/motor module since they are factory programmed for specific operating modes. Even though they look alike, different modules may have completely different functionality. The ECM variable speed motors are c

Important Note: Using the wrong motor/control module voids all product warranties and may produce unexpected results.

CHART CONTINUED ON NEXT PAGE

CHART CONTINUED FROM PREVIOUS PAGE.

Troubleshooting Chart for GE/Regal-Beloit ECM Variable Speed Air Circulator Blower Motors

Symptom	Fault Description(s)	Possible Causes	Corrective Action	Cautions and Notes
- Motor starts, but runs erratically.	- Stays at low CFM despite system call for cool or heat CFM.	- 24 Vac wires miswired or loose. - "R" missing/not connected at motor. - Fan in delay mode.	- Check low voltage (Thermostat) wires and connections. - Verify fan is not in delay mode - wait until delay complete. - Perform motor/control replacement check, ECM motors only.	- Turn power OFF prior to repair. Wait 5 minutes after disconnecting power before opening motor. - Handle electronic motor/control with care.
	- Stays at high CFM.	- "R" missing/not connected at motor. - Fan in delay mode.	- Is fan in delay mode? - wait until delay time complete. - Perform motor/control replacement check, ECM motors only.	- Turn power OFF prior to repair. Wait 5 minutes after disconnecting power before opening motor. - Handle electronic motor/control with care.
- Blower won't shut off.	- Blower won't shut off.	- Current leakage from controls into G, Y, or W.	- Check for Triac switched status or solid state relay.	- Turn power OFF prior to repair.
	- Air noise.	- High static creating high blower speed. - Incorrect supply or return ductwork. - Incorrect or dirty filter(s). - Incorrect blower speed setting.	- Check/replace filter. - Check/correct duct restrictions. - Adjust to correct blower speed setting.	- Turn power OFF prior to repair.
- Excessive noise.	- Noisy blower or cabinet.	- Loose blower housing, panels, etc. - High static creating high blower speed. - Air leaks in ductwork, cabinets, or panels.	- Check for loose blower housing, panels, etc. - Check for air whistling through seams in ducts, cabinets or panels. - Check for cabinet/duct deformation.	- Turn power OFF prior to repair.
	- "Hunts" or "puffs" at high CFM (speed).	- High static creating high blower speed. - Incorrect or dirty filter(s). - Incorrect supply or return ductwork. - Incorrect blower speed setting.	- Does removing panel or filter reduce "puffing"? - Check/replace filter. - Check/correct duct restrictions. - Adjust to correct blower speed setting.	- Turn power OFF prior to repair.
- Evidence of Moisture.	- Motor failure or malfunction has occurred and moisture is present.	- Moisture in motor/control module.	- Replace motor and perform Moisture Check.*	- Turn power OFF prior to repair. Wait 5 minutes after disconnecting power before opening motor. - Handle electronic motor/control with care.

***Moisture Check**

- Connectors are oriented "down" (or as recommended by equipment manufacturer).
- Is condensate drain plugged?
- Check for uncharged condensation.

Note: You must use the correct replacement control/motor module since they are factory programmed for specific operating modes. Even though they look alike, different modules may have completely different functionality. The ECM variable speed motors are c

Important Note: Using the wrong motor/control module voids all product warranties and may produce unexpected results.

SERVICING

S-16E BLOWER PERFORMANCE DATA

SPEED	STATIC	MBR800**-* SCFM	MBR1200**-* SCFM	MBR1600**-* SCFM	MBR2000**-* SCFM
HIGH	0.1	1,240	1,500	1,800	2,160
	0.2	1,170	1,460	1,740	2,080
	0.3	1,120	1,360	1,680	1,990
	0.4	1,060	1,280	1,610	1,890
	0.5	980	1,200	1,520	1,790
	0.6	900	1,110	1,430	1,690
MEDIUM	0.1	900	1,380	1,540	1,730
	0.2	850	1,320	1,490	1,670
	0.3	790	1,270	1,450	1,590
	0.4	740	1,200	1,400	1,520
	0.5	680	1,140	13,560	1,420
	0.6	605	1,040	1,280	1,320
LOW	0.1	650	1,170	1,130	1,520
	0.2	590	1,130	1,100	1,450
	0.3	540	1,080	1,070	1,360
	0.4	500	1,020	1,030	1,290
	0.5	430	950	990	1,200
	0.6	330	830	930	1,090

NOTE: External static is for blower @ 230 Volts. It does not include Coil, Air Filter or Electric Heaters.

S-16F CHECKING HIGH EFFICIENCY MOTORS

The motor is a one piece, fully encapsulated, 3 phase brushless DC (single phase AC input) motor with ball bearing construction.

1. Using a voltmeter, check for 230 volts to the motor connections L and N. If 230 volts is present, proceed to step 2. If 230 volts is not present, check the line voltage circuit to the motor.
2. Using a voltmeter, check for 24 volts from terminal C to either terminal 1, 2, 3, 4, or 5, depending on which tap is being used, at the motor. If voltage present, proceed to step 3. If no voltage, check 24 volt circuit to motor.
3. If voltage was present in steps 1 and 2, the motor has failed and will need to be replaced.

NOTE: When replacing motor, ensure the belly band is between the vents on the motor and the wiring has the proper drip loop to prevent condensate from entering the motor.

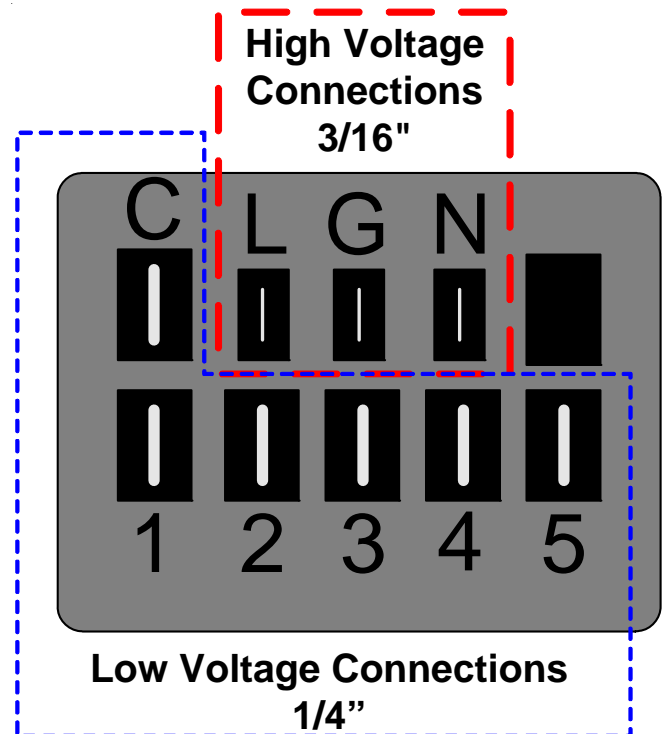

MOTOR CONNECTIONS

SERVICING

S-16G EEM BLOWER REPLACEMENT

For AWUF19-25, AWUF31-32, and AWUF37 Air Handlers.

1. Disconnect power at main electrical panel.
2. Remove front access panel.
3. Remove the two screws on each side holding the lower control box and move out of the way to give access to the blower assembly

Remove lower control Box

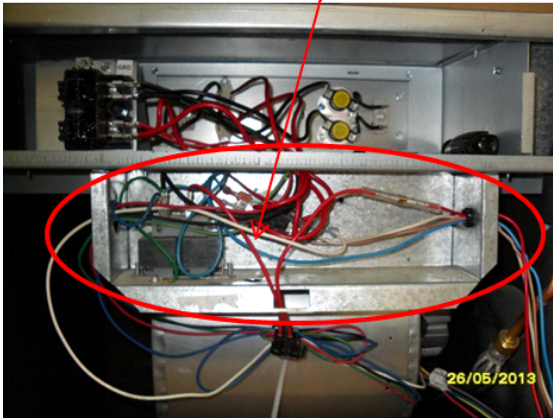

Remove screws on both sides of control box

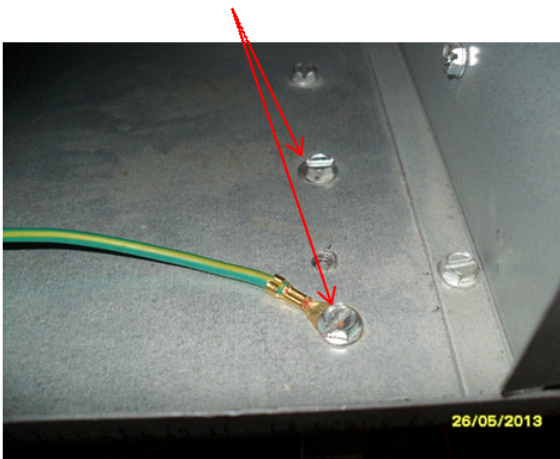

5. Loosen or remove set screw on blower wheel hub and ensure the wheel slides freely on the shaft of the motor.



6. Install cardboard or rug over coil to protect fins from damage.

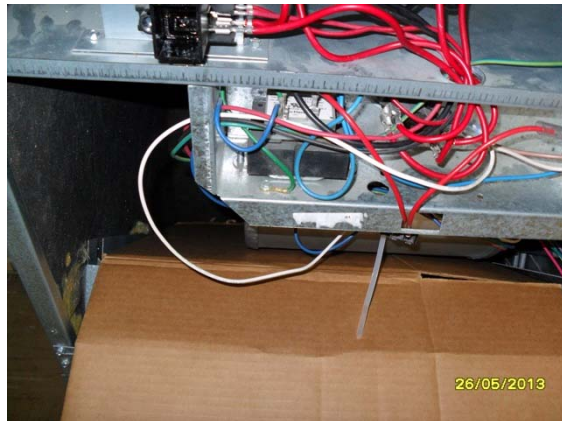

7. Remove the three 3/8" screws holding the blower in place.

Remove Screws and drop blower Assembly and allow to rest on coil

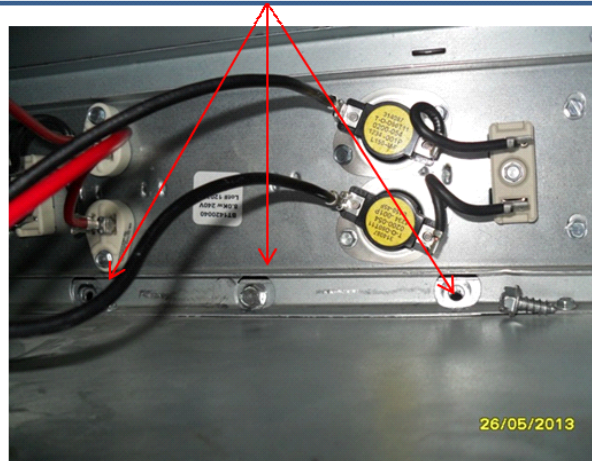

8. Lower blower onto coil.
9. Slide blower assembly all the way to the left side of cabinet.

SERVICING

Slide blower to the left

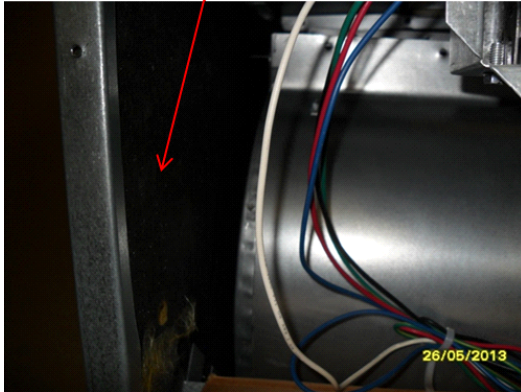

10. Remove the bolts holding the motor bracket to the blower and slide out of blower shell.

Remove screws holding Motor bracket.

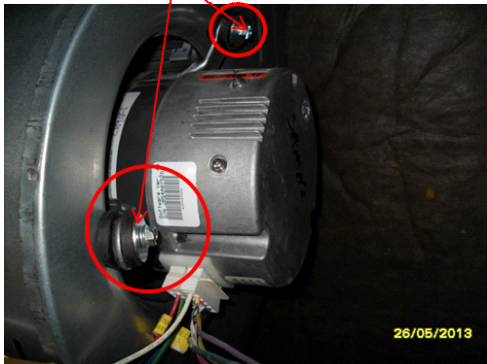

11. Replace the motor and reinstall blower and control box.
12. Reconnect power and test operation.

S-17 CHECKING COMPRESSOR



WARNING

Hermetic compressor electrical terminal venting can be dangerous. When insulating material which supports a hermetic compressor or electrical terminal suddenly disintegrates due to physical abuse or as a result of an electrical short between the terminal and the compressor housing, the terminal may be expelled, venting the vapor and liquid contents of the compressor housing and system.

If the compressor terminal PROTECTIVE COVER and gasket (if required) are not properly in place and secured, there is a remote possibility if a terminal vents, that the vaporous and liquid discharge can be ignited, spouting flames several feet, causing potentially severe or fatal injury to anyone in its path.

This discharge can be ignited external to the compressor if the terminal cover is not properly in place and if the discharge impinges on a sufficient heat source.

Ignition of the discharge can also occur at the venting terminal or inside the compressor, if there is sufficient contaminant air present in the system and an electrical arc occurs as the terminal vents.

Ignition cannot occur at the venting terminal without the presence of contaminant air, and cannot occur externally from the venting terminal without the presence of an external ignition source.

Therefore, proper evacuation of a hermetic system is essential at the time of manufacture and during servicing.

To reduce the possibility of external ignition, all open flame, electrical power, and other heat sources should be extinguished or turned off prior to servicing a system.

SERVICING

S-17A RESISTANCE TEST

Each compressor is equipped with an internal overload.

The line break internal overload senses both motor amperage and winding temperature. High motor temperature or amperage heats the disc causing it to open, breaking the common circuit within the compressor on single phase units.

Heat generated within the compressor shell, usually due to recycling of the motor, high amperage or insufficient gas to cool the motor, is slow to dissipate. Allow at least three to four hours for it to cool and reset, then retest.

Fuse, circuit breaker, ground fault protective device, etc. has not tripped -

⚠ WARNING

HIGH VOLTAGE!
Disconnect ALL power before servicing or installing. Multiple power sources may be present. Failure to do so may cause property damage, personal injury or death.



1. Remove the leads from the compressor terminals.

⚠ WARNING

Hermetic compressor electrical terminal venting can be dangerous. When insulating material which supports a hermetic compressor or electrical terminal suddenly disintegrates due to physical abuse or as a result of an electrical short between the terminal and the compressor housing, the terminal may be expelled, venting the vapor and liquid contents of the compressor housing and system.

2. Using an ohmmeter, test continuity between terminals S-R, C-R, and C-S, on single phase units or terminals T2, T2 and T3, on 3 phase units.

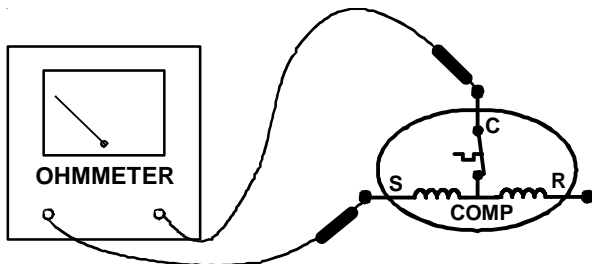

TESTING COMPRESSOR WINDINGS

If either winding does not test continuous, replace the compressor.

NOTE: If an open compressor is indicated, allow ample time for the internal overload to reset before replacing compressor.

S-17B GROUND TEST

If fuse, circuit breaker, ground fault protective device, etc., has tripped, this is a strong indication that an electrical problem exists and must be found and corrected. The circuit protective device rating must be checked, and its maximum rating should coincide with that marked on the equipment nameplate.

With the terminal protective cover in place, it is acceptable to replace the fuse or reset the circuit breaker ONE TIME ONLY to see if it was just a nuisance opening. If it opens again, DO NOT continue to reset.

Disconnect all power to unit, making sure that **all** power legs are open.

1. DO NOT remove protective terminal cover. Disconnect the three leads going to the compressor terminals at the nearest point to the compressor.
2. Identify the leads and using an ohmmeter on the R x 10,000 scale or the highest resistance scale on your ohmmeter check the resistance between each of the three leads separately to ground (such as an unpainted tube on the compressor).
3. If a ground is indicated, then carefully remove the compressor terminal protective cover and inspect for loose leads or insulation breaks in the lead wires.
4. If no visual problems indicated, carefully remove the leads at the compressor terminals.
5. Carefully retest for ground, directly between compressor terminals and ground.
6. If ground is indicated, replace the compressor. The resistance reading should be infinity. If there is any reading on meter, there is some continuity to ground and compressor should be considered defective.

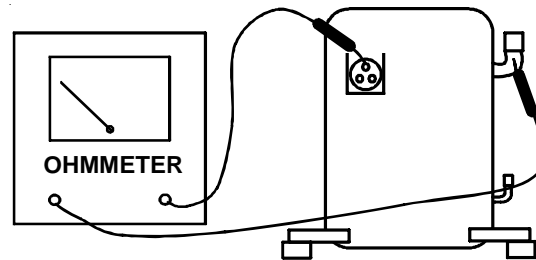

⚠ WARNING

Damage can occur to the glass embedded terminals if the leads are not properly removed. This can result in terminal and hot oil discharging.

S-17C UNLOADER TEST PROCEDURE

A nominal 24-volt direct current coil activates the internal unloader solenoid. The input control circuit voltage must be 18 to 28 volt ac. The coil power requirement is 20 VA. The external electrical connection is made with a molded plug assembly. This plug contains a full wave rectifier to supply direct current to the unloader coil.

SERVICING



**UNLOADER SOLENOID
(Molded Plug)**

Unloader Test Procedure

If it is suspected that the unloader is not working, the following methods may be used to verify operation.

1. Operate the system and measure compressor current. Cycle the unloader ON and OFF at 10 second intervals. The compressor amperage should go up or down at least 25 percent.
2. If step one does not give the expected results, shut unit off. Apply 18 to 28 volt ac to the unloader molded plug leads and listen for a click as the solenoid pulls in. Remove power and listen for another click as the unloader returns to its original position.
3. If clicks can't be heard, shut off power and remove the control circuit molded plug from the compressor and measure the unloader coil resistance. The resistance should be 32 to 60 ohms, depending on compressor temperature.
4. Next check the molded plug.
 - A. Voltage check: Apply control voltage to the plug wires (18 to 28 volt ac). The measured **dc** voltage at the female connectors in the plug should be around 15 to 27 vdc.
 - B. Resistance check: Measure the resistance from the end of one molded plug lead to either of the two female connectors in the plug. One of the connectors should read close to zero ohms while the other should read infinity. Repeat with other wire. The same female connector as before should read zero while the other connector again reads infinity. Reverse polarity on the ohmmeter leads and repeat. The female connector that read infinity previously should now read close to zero ohms.
 - C. Replace plug if either of these test methods doesn't show the desired results.

S-17D OPERATION TEST

If the voltage, capacitor, overload and motor winding test fail to show the cause for failure:

⚠ WARNING
HIGH VOLTAGE!
Disconnect ALL power before servicing or installing. Multiple power sources may be present. Failure to do so may cause property damage, personal injury or death.



1. Remove unit wiring from disconnect switch and wire a test cord to the disconnect switch.

NOTE: The wire size of the test cord must equal the line wire size and the fuse must be of the proper size and type.

2. With the protective terminal cover in place, use the three leads to the compressor terminals that were disconnected at the nearest point to the compressor and connect the common, start and run clips to the respective leads.
3. Connect good capacitors of the right MFD and voltage rating into the circuit as shown.
4. With power ON, close the switch.

⚠ WARNING
Line Voltage now present.

- A. If the compressor starts and continues to run, the cause for failure is somewhere else in the system.
- B. If the compressor fails to start - replace.

COPELAND COMPRESSOR

03	A	12345	L
YEAR	MONTH	SERIAL NUMBER	PLANT

S-17E CHECKING 3-PHASE SCROLL COMPRESSOR ROTATION

Verify the proper rotation of Copeland scroll compressors as follows:

NOTE: The compressor may run backwards (noisy operation) for 1 or 2 seconds at shutdown. This is normal and does not harm the compressor.

1. Install gauges and verify that the suction pressure drops while the discharge pressure increases.
2. Listen for normal compressor sound levels. Reverse rotation results in elevated or unusual sound levels.
3. Reverse rotation will result in substantially reduced amp draw from tabulated values.

To correct improper rotation, switch any two power supply leads at the outdoor unit contactor.

SERVICING

The 3-phase scroll compressors are direction of rotation sensitive. They will rotate in either direction depending on the phasing of the power. There is no negative impact on durability caused by operating 3-phase compressors in reversed rotation. The compressor's internal protector will trip, de-energizing the compressor. Continued operation of 3-phase scroll compressors with the rotation reversed will contribute to compressor failure. All 3-phase scroll compressors should be checked for correct phase rotation.

S-18 TESTING CRANKCASE HEATER (OPTIONAL ITEM)

The crankcase heater must be energized a minimum of four (4) hours before the condensing unit is operated.

Crankcase heaters are used to prevent migration or accumulation of refrigerant in the compressor crankcase during the off cycles and prevents liquid slugging or oil pumping on start up.

A crankcase heater will not prevent compressor damage due to a floodback or over charge condition.



WARNING

Disconnect ALL power before servicing.

1. Disconnect the heater lead in wires.
2. Using an ohmmeter, check heater continuity - should test continuous. If not, replace.

NOTE: The positive temperature coefficient crankcase heater is a 40 watt 265 voltage heater. The cool resistance of the heater will be approximately 1800 ohms. The resistance will become greater as the temperature of the compressor shell increases.

S-21 CHECKING REVERSING VALVE AND SOLENOID

Occasionally the reversing valve may stick in the heating or cooling position or in the mid-position.

When stuck in the mid-position, part of the discharge gas from the compressor is directed back to the suction side, resulting in excessively high suction pressure. An increase in the suction line temperature through the reversing valve can also be measured. Check operation of the valve by starting the system and switching the operation from COOLING to HEATING cycle.

If the valve fails to change its position, test the voltage (24V) at the valve coil terminals, while the system is on the COOLING cycle.

If no voltage is registered at the coil terminals, check the operation of the thermostat and the continuity of the connecting wiring from the "O" terminal of the thermostat to the unit.

S-24 TESTING DEFROST CONTROL

To check the defrost control for proper sequencing, proceed as follows: With power ON; unit not running.

1. Jumper defrost thermostat by placing a jumper wire across the terminals "DFT" and "R"/"R-DFT" at defrost control board.
2. Connect jumper across test pins on defrost control board.

3. Set thermostat to call for heating. System should go into defrost within 21 seconds.
4. Immediately remove jumper from test pins.
5. Using VOM check for voltage across terminals "C & O". Meter should read 24 volts.
6. Using VOM check for voltage across fan terminals DF1 and DF2 on the board. You should read line voltage (208-230 VAC) indicating the relay is open in the defrost mode.
7. Using VOM check for voltage across "W"/"W2" & "C" terminals on the board. You should read 24 volts.
8. If not as above, replace control board.
9. Set thermostat to off position and disconnect power before removing any jumpers or wires.

NOTE: Remove jumper across defrost thermostat before returning system to service.

S-25 TESTING DEFROST THERMOSTAT

1. Install a thermocouple type temperature test lead on the tube adjacent to the defrost control. Insulate the lead point of contact.
2. Check the temperature at which the control closes its contacts by lowering the temperature of the control. Part # 0130M00009P which is used on 2 and 2.5 ton units should close at $34^{\circ}\text{F} \pm 5^{\circ}\text{F}$. Part # 0130M00001P or B1370803 which is used on 3 thru 5 ton units should close at $31^{\circ}\text{F} \pm 3^{\circ}\text{F}$.
3. Check the temperature at which the control closes its contacts by lowering the temperature of the control. Part # 0130M00085, which is used on units with 5 mm coils, should close at $30^{\circ}\text{F} \pm 5^{\circ}\text{F}$.
4. Check the temperature at which the control opens its contacts by raising the temperature of the control. Part # 0130M00009P which is used on 2 and 2.5 ton units should open at $60^{\circ}\text{F} \pm 5^{\circ}\text{F}$. Part # 0130M00001P or B1370803 which is used on 3 thru 5 ton units should open at $75^{\circ}\text{F} \pm 6^{\circ}\text{F}$.
5. Check the temperature at which the control opens its contacts by raising the temperature of the control. Part # 0130M00085, which is used on units with 5 mm coils, should open at $60^{\circ}\text{F} \pm 5^{\circ}\text{F}$.
6. If not as above, replace control.

SEQUENCE OF OPERATION

Refer to the installation instructions and wiring diagrams provided with the MBR/AR*F for specific wiring connections and system configuration.

MBR/AR*F WITH SINGLE STAGE CONDENSERS

1.0 Cooling Operation

- 1.1 On a demand for cooling, the room thermostat energizes "G" and "Y" and 24Vac is supplied to "Y" at the condensing unit and the "G" terminal on the EBTDR board.
- 1.2 The compressor and condenser fan are turned on and after a 7 second on delay, the relay on the EBTDR board is energized and the blower motor starts.

SERVICING

1.3 When the cooling demand “Y” is satisfied, the room thermostat removes the 24Vac from “G” and “Y”.

1.4 The compressor and condenser fan are turned off and after a 65 second delay off, the relay on the EBTDR board is de-energized and the blower is turned off.

2.0 Heating Operation

2.1 On a demand for heat, the room thermostat energizes “W1” and 24Vac is supplied to heat sequencer, HR1, on the heater assembly.

2.2 The contacts M1 and M2 will close within 10 to 20 seconds and turn on heater element #1. The normally closed contacts on the EBTDR are also connected to terminal M1. When M1 and M2 close, the blower motor will be energized thru the normally closed contacts on the EBTDR board. At the same time, if the heater assembly contains a second heater element, HR1 will contain a second set of contacts, M3 and M4, which will close to turn on heater element #2.

NOTE: If more than two heater elements are on the heater assembly, it will contain a second heat sequencer, HR2, which will control the 3rd and 4th heater elements if available. If the first stage heat demand, “W1” cannot be satisfied by the heat pump, the temperature indoors will continue to drop. The room thermostat will then energize “W2” and 24Vac will be supplied to HR2 on the heater assembly. When the “W2” demand is satisfied, the room thermostat will remove the 24Vac from HR2. The contacts on HR2 will open between 30 to 70 seconds and heater elements #3 and #4 will be turned off. **On most digital/electronic thermostats, “W2” will remain energized until the first stage demand “W1” is satisfied and then the “W1” and “W2” demands will be removed.**

2.3 When the “W1” heat demand is satisfied, the room thermostat will remove the 24Vac from HR1. Both set of contacts on the relay opens within 30 to 70 seconds and turn off the heater element(s) and the blower motor.

MBR/AR*F WITH SINGLE STAGE HEAT PUMPS

3.0 Cooling Operation

On heat pump units, when the room thermostat set to the cooling mode, 24Vac is supplied to “O” which energizes the reversing valve. As long as the thermostat is set for cooling, the reversing valve will be in the energized position for cooling.

3.1 On a demand for cooling, the room thermostat energizes “G” and “Y” and 24Vac is supplied to “Y” at the heat pump and the “G” terminal on the EBTDR board.

3.2 The heat pump turned on in the cooling mode and after a 7 second on delay, the relay on the EBTDR board is energized and the blower motor starts.

3.3 When the cooling demand is satisfied, the room thermostat removes the 24Vac from “G” and “Y”.

3.4 The heat pump is turned off and after a 65 second delay off, the relay on the EBTDR board is de-energized and the blower motor is turned off.

4.0 Heating Operation

On heat pump units, when the room thermostat set to the heating mode, the reversing valve is not energized. As long as the thermostat is set for heating, the reversing valve will be in the de-energized position for heating except during a defrost cycle. Some installations may use one or more outdoor thermostats to restrict the amount of electric heat that is available above a preset ambient temperature. Use of optional controls such as these can change the operation of the electric heaters during the heating mode. This sequence of operation does not cover those applications.

4.1 On a demand for first stage heat with heat pump units, the room thermostat energizes “G” and “Y” and 24Vac is supplied to “Y” at the heat pump unit and the “G” terminal on the EBTDR board. The heat pump is turned on in the heating mode and the blower motor starts after a 7 second on delay.

4.2 If the first stage heat demand cannot be satisfied by the heat pump, the temperature indoors will continue to drop. The room thermostat will then energize terminal “W2” for second stage heat and 24Vac will be supplied to heat sequencer HR1 on the heater assembly.

4.3 HR1 contacts M1 and M2 will close will close within 10 to 20 seconds and turn on heater element #1. At the same time, if the heater assembly contains a second heater element, HR1 will contain a second set of contacts, M3 and M4, which will close and turn on heater element #2. The blower motor is already on as a result of terminal “G” on the EBTDR board being energized for the first stage heat demand.

NOTE: If more than two heater elements are on the heater assembly, it will contain a second heat sequencer, HR2, which will control the 3rd and 4th heater elements if available. If the second stage heat demand, “W2” cannot be satisfied by the heat pump, the temperature indoors will continue to drop. The room thermostat will then energize “W3” and 24Vac will be supplied to HR2 on the heater assembly. When the “W3” demand is satisfied, the room thermostat will remove the 24Vac from HR2. The contacts on HR2 will open between 30 to 70 seconds and heater elements #3 and #4 will be turned off. **On most digital/electronic thermostats, “W3” will remain energized until the first stage heat demand “Y” is satisfied and then the “G”, “Y”, “W2” and “W3” demands will be removed.**

4.4 As the temperature indoors increase, it will reach a point where the second stage heat demand, “W2”, is satisfied. When this happens, the room thermostat will remove the 24Vac from the coil of HR1. The contacts on HR1 will open between 30 to 70 seconds and turn off both heater element(s). The heat pump remains on along with the blower motor because the “Y” demand for first stage heat will still be present.

4.5 When the first stage heat demand “Y” is satisfied, the room thermostat will remove the 24Vac from “G” and “Y”. The heat pump is turned off and the blower motor turns off after a 65 second off delay.

SERVICING

5.0 Defrost Operation

On heat pump units, when the room thermostat is set to the heating mode, the reversing valve is not energized. As long as the thermostat is set for heating, the reversing valve will be in the de-energized position for heating except during a defrost cycle.

5.1 The heat pump will be on and operating in the heating mode as described the Heating Operation in section 4.

5.2 The defrost control in the heat pump unit checks to see if a defrost is needed every 30, 60 or 90 minutes of heat pump operation depending on the selectable setting by monitoring the state of the defrost thermostat attached to the outdoor coil.

5.3 If the temperature of the outdoor coil is low enough to cause the defrost thermostat to be closed when the defrost board checks it, the board will initiate a defrost cycle.

5.4 When a defrost cycle is initiated, the contacts of the HVDR relay on the defrost board open and turns off the outdoor fan. The contacts of the LVDR relay on the defrost board closes and supplies 24Vac to "O" and "W2". The reversing valve is energized and the contact on HR1 close and turns on the electric heater(s). The unit will continue to run in this mode until the defrost cycle is completed.

a. For models with defrost control PCBDM133 or PCBDM160, a 30 second compressor delay at defrost initiation/termination is optional. As shipped from the factory, the control is set for the delay ("DLY"), which will turn the compressor off for 30 seconds while the reversing valve shifts to/from the cooling mode position. To bypass the delay, which typically reduces sound levels during defrost mode, change the pin settings from "DLY" to "NORM".

5.5 When the temperature of the outdoor coil rises high enough to causes the defrost thermostat to open, the defrost cycle will be terminated. If at the end of the programmed 10 minute override time the defrost thermostat is still closed, the defrost board will automatically terminate the defrost cycle.

5.6 When the defrost cycle is terminated, the contacts of the HVDR relay will close to start the outdoor fan and the contacts of the LVDR relay will open and turn off the reversing valve and electric heater(s). The unit will now be back in a normal heating mode with a heat pump demand for heating as described in the Heating Operation in section 4. See section 5.4a.

MBE/AEPF WITH GSX, SSX, ASX, DSX, VSX

MBE ELECTRONIC BLOWER TIME DELAY RELAY AEPF AIR HANDLER

SEQUENCE OF OPERATION

This document covers the basic sequence of operation for a typical application with a mercury bulb thermostat. When a digital/electronic thermostat is used, the on/off staging of the auxiliary heat will vary. **Refer to the installation instructions and wiring diagrams provided with the MBE/AEPF for specific wiring connections, dip switch settings and system configuration.**

MBE/AEPF WITH SINGLE STAGE GSX, ASX, SSX, and VSX CONDENSERS

When used with a single stage GSX, SSX, ASX, and VSX condensers, dip switch #4 must be set to the on position on the VSTB inside the MBE/AEPF. The "Y" output from the indoor thermostat must

be connected to the yellow wire labeled "Y/Y2" inside the wire bundle marked "Thermostat" and the yellow wire labeled "Y/Y2" inside the wire bundle marked "Outdoor Unit" must be connected to "Y" at the condenser. **The orange jumper wire from terminal "Y1" to terminal "O" on the VSTB** inside the MBE/AEPF must remain connected.

1.0 Cooling Operation

1.1 On a demand for cooling, the room thermostat energizes "G" and "Y" and 24Vac is supplied to "G" and "Y/Y2" of the MBE/AEPF unit. The VSTB inside the MBE/AEPF will turn on the blower motor and the motor will ramp up to the speed programmed in the motor based on the settings for dip switch 5 and 6. The VSTB will supply 24Vac to "Y" at the condenser and the compressor and condenser are turned on.

1.2 When the cooling demand is satisfied, the room thermostat removes the 24Vac from "G" and "Y". The MBE/AEPF removes the 24Vac from "Y" at the condenser and the compressor and condenser fan are turned off. The blower motor will ramp down to a complete stop based on the time and rate programmed in the motor.

2.0 Heating Operation

2.1 On a demand for heat, the room thermostat energizes "W1" and 24Vac is supplied to terminal "E/W1" of the VSTB inside the MBE/AEPF unit. The VSTB will turn on the blower motor and the motor will ramp up to the speed programmed in the motor based on the settings for dip switch 1 and 2. The VSTB will supply 24Vac to heat sequencer HR1 on the electric heater assembly.

2.2 HR1 contacts M1 and M2 will close within 10 to 20 seconds and turn on heater element #1. At the same time, if the heater assembly contains a second heater element, HR1 will contain a second set of contacts, M3 and M4, which will close and turn on heater element #2.

NOTE: If more than two heater elements are on the heater assembly, it will contain a second heat sequencer, HR2, which will control the 3rd and 4th heater elements if available. **For the 3rd and 4th heater elements to operate on a second stage heat demand, the PJ4 jumper on the VSTB inside the MBE/AEPF must be cut.** With the PJ4 jumper cut, the VSTB will run the blower motor on low speed on a "W1" only demand. If the first stage heat demand, "W1" cannot be satisfied by the heat pump, the temperature indoors will continue to drop. The room thermostat will then energize "W2" and 24Vac will be supplied to HR2 on the heater assembly and the blower motor will change to high speed. When the "W2" demand is satisfied, the room thermostat will remove the 24Vac from "W2" and the VSTB will remove the 24Vac from HR2. The contacts on HR2 will open between 30 to 70 seconds and heater elements #3 and #4 will be turned off and the blower motor will change to low speed. **On most digital/electronic thermostats, "W2" will remain energized until the first stage demand "W1" is satisfied and then the "W1" and "W2" demands will be removed.**

SERVICING

2.3 When the “W1” heat demand is satisfied, the room thermostat will remove the 24Vac from “E/W1” and the VSTB removes the 24Vac from HR1. The contacts on HR1 will open between 30 to 70 seconds and turn off the heater element(s) and the blower motor ramps down to a complete stop.

MBE/AEPF WITH SINGLE STAGE

GSZ, SSZ, ASZ, and VSZ HEAT PUMPS

When used with a single stage GSZ, SSZ, ASZ, or VSZ heat pumps, dip switch #4 must be set to the ON position on the VSTB inside the MBE. The “Y” output from the indoor thermostat must be connected to the yellow wire labeled “Y/Y2” inside the wire bundle marked “Thermostat” and the yellow wire labeled “Y/Y2” inside the wire bundle marked “Outdoor Unit” must be connected to “Y” at the heat pump. **The orange jumper wire from terminal “Y1” to terminal “O” on the VSTB inside the MBE/AEPF must be removed.**

3.0 COOLING OPERATION

On heat pump units, when the room thermostat is set to the cooling mode, 24Vac is supplied to terminal “O” of the VSTB inside the MBE/AEPF unit. The VSTB will supply 24Vac to “O” at the heat pump to energize the reversing valve. As long as the thermostat is set for cooling, the reversing valve will be in the energized position for cooling.

3.1 On a demand for cooling, the room thermostat energizes “G” and “Y” and 24Vac is supplied to terminals “G” and “Y/Y2” of the MBE/AEPF unit. The VSTB will turn on the blower motor and the motor will ramp up to the speed programmed in the motor based on the settings of dip switch 5 and 6. The VSTB will supply 24Vac to “Y” at the heat pump.

3.2 The heat pump is turned on in the cooling mode.

3.3 When the cooling demand is satisfied, the room thermostat removes the 24Vac from “G” and “Y/Y2” of the MBE/AEPF and the VSTB removes the 24Vac from “Y” at the heat pump. The heat pump is turned off and the blower motor will ramp down to a complete stop based on the time and rate programmed in the motor.

4.0 Heating Operation

On heat pump units, when the room thermostat is set to the heating mode, the reversing valve is not energized. As long as the thermostat is set for heating, the reversing valve will be in the de-energized position for heating except during a defrost cycle. Some installations may use one or more outdoor thermostats to restrict the amount of electric heat that is available above a preset ambient temperature. Use of optional controls such as these can change the operation of the electric heaters during the heating mode. This sequence of operation does not cover those applications.

4.1 On a demand for first stage heat with heat pump units, the room thermostat energizes “Y” and “G” and 24Vac is supplied to “G” and “Y/Y2” of the MBE/AEPF. The VSTB will turn on the blower motor and the motor will ramp up to the speed programmed in the motor based on the settings of dip switch 1 and 2. The VSTB will supply 24Vac to “Y” at the heat pump and the heat pump is turned on in the heating mode.

4.2 If the first stage heat demand cannot be satisfied by the heat

pump, the temperature indoors will continue to drop. The room thermostat will then energize terminal “W2” for second stage heat and 24Vac will be supplied to “E/W1” of the MBE/AEPF. The VSTB will supply 24Vac to heat sequencer, HR1, on the electric heater assembly.

4.3 HR1 contacts M1 and M2 will close within 10 to 20 seconds and turn on heater element #1. At the same time, if the heater assembly contains a second heater element, HR1 will contain a second set of contacts, M3 and M4, which will close to turn on heater element #2.

Note: If more than two heater elements are on the heater assembly, it will contain a second heat sequencer, HR2, which will control the 3rd and 4th heater elements if available. **For the 3rd and 4th heater elements to operate on a third stage heat demand, the PJ4 jumper on the VSTB inside the MBE/AEPF must be cut.** If the second stage heat demand, “W2”, cannot be satisfied by the heat pump, the temperature indoors will continue to drop. The room thermostat will then energize “W3” and 24Vac will be supplied to “W/W2” of the MBE/AEPF. The VSTB will supply 24Vac to HR2 on the electric heater assembly. When the “W3” demand is satisfied, the room thermostat will remove the 24Vac from “W/W2” of the MBE/AEPF. The contacts on HR2 will open between 30 to 70 seconds and heater elements #3 and #4 will be turned off. **On most digital/electronic thermostats, “W3” will remain energized until the first stage demand “Y” is satisfied and then the “G”, “Y”, “W2” and “W3” demands will be removed.**

4.4 As the temperature indoors increase, it will reach a point where the second stage heat demand, “W2”, is satisfied. When this happens, the room thermostat will remove the 24Vac from “E/W1” of the MBE/AEPF. The contacts on HR1 will open between 30 to 70 seconds and turn off both heater element(s). The heat pump remains on along with the blower motor because the “Y” demand for first stage heat will still be present.

4.5 When the first stage heat demand “Y” is satisfied, the room thermostat will remove the 24Vac from “G” and “Y/Y2” of the MBE/AEPF. The VSTB removes the 24Vac from “Y” at the heat pump and the heat pump is turned off. The blower motor will ramp down to a complete stop based on the time and rate programmed in the motor control.

5.0 DEFROST OPERATION

On heat pump units, when the room thermostat is set to the heating mode, the reversing valve is not energized. As long as the thermostat is set for heating, the reversing valve will be in the de-energized position for heating except during a defrost cycle.

5.1 The heat pump will be on and operating in the heating mode as described the Heating Operation in section 4.

5.2 The defrost control in the heat pump unit checks to see if a defrost is needed every 30, 60 or 90 minutes of heat pump operation depending on the selectable setting by monitoring the state of the defrost thermostat attached to the outdoor coil.

5.3 If the temperature of the outdoor coil is low enough to cause the defrost thermostat to be closed when the defrost board checks it, the board will initiate a defrost cycle.

SERVICING

5.4 When a defrost cycle is initiated, the contacts of the HVDR relay on the defrost board open and turns off the outdoor fan. The contacts of the LVDR relay on the defrost board closes and supplies 24Vac to “O” and “W2”. The reversing valve is energized and the contacts on HR1 close and turns on the electric heater(s). The unit will continue to run in this mode until the defrost cycle is completed.

a. For models with defrost control PCBDM133 or PCBDM160, a 30 second compressor delay at defrost initiation/termination is optional. As shipped from the factory, the control is set for the delay (“DLY”), which will turn the compressor off for 30 seconds while the reversing valve shifts to/from the cooling mode position. To bypass the delay, which typically reduces sound levels during defrost mode, change the pin settings from “DLY” to “NORM”.

5.5 When the temperature of the outdoor coil rises high enough to causes the defrost thermostat to open, the defrost cycle will be terminated. If at the end of the programmed 10 minute override time the defrost thermostat is still closed, the defrost board will automatically terminate the defrost cycle.

5.6 When the defrost cycle is terminated, the contacts of the HVDR relay on the defrost board will close to start the outdoor fan and the contacts of the LVDR relay will open and turn off the reversing valve and electric heater(s). The unit will now be back in a normal heating mode with a heat pump demand for heating as described in the Heating Operation in section 4. See section 5.4a.

MBE/AEPF WITH TWO STAGE ASX & DSX CONDENSERS

1.0 COOLING OPERATION

When used with the ASX & DSX two stage condensers, dip switch #4 must be set to the OFF position on the VSTB inside the MBE/AEPF. The “Y1” output from the indoor thermostat must be connected to the purple wire labeled “Ylow/Y1” inside the wire bundle marked “Thermostat” and the purple wire labeled “Ylow/Y1” inside the wire bundle marked “Outdoor Unit” must be connected to “Ylow/Y1” at the condenser. The “Y2” output from the indoor thermostat must be connected to the yellow wire labeled “Y/Y2” inside the wire bundle marked “Thermostat” and the yellow wire labeled “Y/Y2” inside the wire bundle marked “Outdoor Unit” must be connected to “Y/Y2” at the condenser. **The orange jumper wire from terminal “Y1” to terminal “O” on the VSTB inside the MBE/AEPF must remain connected.**

1.1 On a demand for cooling, the room thermostat energizes “G” and “Y1” and 24Vac is supplied to “G” and “Ylow/Y1” of the MBE/AEPF unit. The VSTB inside the MBE/AEPF will turn on the blower motor and the motor will ramp up to 60% of the speed programmed in the motor based on the settings for dip switch 5 and 6. The VSTB will supply 24Vac to “Ylow/Y1” at the condenser and the compressor and condenser fan starts in low speed operation.

1.2 If first stage cooling cannot satisfy the demand, the room thermostat will energize “Y2” and supply 24Vac to the MBE/AEPF unit. The blower motor will change to the cfm for high speed operation and the VSTB will supply 24Vac to “Y/Y2” at the condenser and the compressor and condenser fan will change to high speed operation. When the “Y2” demand is

satisfied, the thermostat will remove the “Y2” demand and the VSTB will remove the 24Vac from “Y/Y2” at the condenser. The blower will drop to 60% of the programmed cfm and the compressor and condenser fan will change to low speed. **On most digital/electronic thermostats, “Y2” will remain energized until the first stage cooling demand “Y1” is satisfied and then the “G”, “Y1” and “Y2” demands will be removed.**

1.3 When the first stage cooling demand, “Y1”, is satisfied, the room thermostat removes the 24Vac from “G” and “Y1”. The MBE/AEPF removes the 24Vac from “Ylow/Y1” at the condenser and the compressor and condenser fan are turned off. The blower motor will ramp down to a complete stop based on the time and rate programmed in the motor.

2.0 Heating Operation

2.1 On a demand for heat, the room thermostat energizes “W1” and 24Vac is supplied to terminal “E/W1” of the VSTB inside the MBE/AEPF unit. The VSTB will turn on the blower motor and the motor will ramp up to the speed programmed in the motor based on the settings for dip switch 1 and 2. The VSTB will supply 24Vac to heat sequencer HR1 on the electric heater assembly.

2.2 HR1 contacts M1 and M2 will close within 10 to 20 seconds and turn on heater element #1. At the same time, if the heater assembly contains a second heater element, HR1 will contain a second set of contacts, M3 and M4, which will close and turn on heater element #2.

Note: If more than two heater elements are on the heater assembly, it will contain a second heat sequencer, HR2, which will control the 3rd and 4th heater elements if available. **For the 3rd and 4th heater elements to operate on a second stage heat demand, the PJ4 jumper on the VSTB inside the MBE/AEPF must be cut.** With the PJ4 jumper cut, the VSTB will run the blower motor on low speed on a “W1” only demand. If the first stage heat demand, “W1” cannot be satisfied by the heat pump, the temperature indoors will continue to drop. The room thermostat will then energize “W2” and 24Vac will be supplied to HR2 on the heater assembly and the blower motor will change to high speed. When the “W2” demand is satisfied, the room thermostat will remove the 24Vac from “W2” and the VSTB will remove the 24Vac from HR2. The contacts on HR2 will open between 30 to 70 seconds and heater elements #3 and #4 will be turned off and the blower motor will change to low speed. **On most digital/electronic thermostats, “W2” will remain energized until the first stage demand “W1” is satisfied and then the “W1” and “W2” demands will be removed.**

2.3 When the “W1” heat demand is satisfied, the room thermostat will remove the 24Vac from “E/W1” and the VSTB removes the 24Vac from HR1. The contacts on HR1 will open between 30 to 70 seconds and turn off the heater element(s) and the blower motor ramps down to a complete stop.

SERVICING

MBE/AEPF WITH TWO STAGE ASZ & DSZ HEAT PUMP UNITS

3.0 Cooling Operation

When used with the ASZ & DSZ two stage heat pumps, dip switch #4 must be set to the OFF position on the VSTB inside the MBE/AEPF. The “Y1” output from the indoor thermostat must be connected to the purple wire labeled “Ylow/Y1” inside the wire bundle marked “Thermostat” and the purple wire labeled “Ylow/Y1” inside the wire bundle marked “Outdoor Unit” must be connected to “Y” at the heat pump. The “Y2” output from the indoor thermostat must be connected to the yellow wire labeled “Y/Y2” inside the wire bundle marked “Thermostat” and the yellow wire labeled “Y/Y2” inside the wire bundle marked “Outdoor Unit” must be connected to “Y/Y2” at the heat pump. **The orange jumper wire from terminal “Y1” to terminal “O” on the VSTB inside the MBE/AEPF must be removed.**

On heat pump units, when the room thermostat is set to the cooling mode, 24Vac is supplied to terminal “O” of the VSTB inside the MBE unit. The VSTB will supply 24Vac to “O” at the heat pump to energize the reversing valve. As long as the thermostat is set for cooling, the reversing valve will be in the energized position for cooling.

- 3.1 On a demand for cooling, the room thermostat energizes “G” and “Y1” and 24Vac is supplied to “G” and “Ylow/Y1” of the MBE unit. The VSTB inside the MBE will turn on the blower motor and the motor will ramp up to 60% of the speed programmed in the motor based on the settings for dip switch 5 and 6. The VSTB will supply 24Vac to “Y” at the heat pump and the compressor and outdoor fan starts in low speed operation.
- 3.2 If first stage cooling cannot satisfy the demand, the room thermostat will energize “Y2” and supply 24Vac to “Y/Y2” of the MBE unit. The blower motor will change to the cfm for high speed operation and the VSTB will supply 24Vac to “Y2” at the heat pump. The compressor and outdoor fan will change to high speed operation. When the “Y2” demand is satisfied, the thermostat will remove the “Y2” demand and the VSTB will remove the 24Vac from “Y2” at the heat pump. The blower will drop to 60% of the programmed cfm and the compressor and outdoor fan will change to low speed operation. **On most digital/electronic thermostats, “Y2” will remain energized until the first stage cooling demand “Y1” is satisfied and then the “G”, “Y1” and “Y2” demands will be removed.**
- 3.3 When the first stage cooling demand, “Y1”, is satisfied, the room thermostat removes the 24Vac from “G” and “Y1”. The VSTB removes the 24Vac from “Y” at the heat pump and the compressor and outdoor fan are turned off. The blower motor will ramp down to a complete stop based on the time and rate programmed in the motor.

4.0 Heating Operation

On heat pump units, when the room thermostat is set to the heating mode, the reversing valve is not energized. As long as the thermostat is set for heating, the reversing valve will be in the de-energized position for heating except during a defrost cycle. Some installations may use one or more outdoor thermostats to restrict the amount of electric heat

that is available above a preset ambient temperature. Use of optional controls such as these can change the operation of the electric heaters during the heating mode. This sequence of operation does not cover those applications.

- 4.1 On a demand for first stage heat with heat pump units, the room thermostat energizes “G” and “Y1” and 24Vac is supplied to “G” and “Ylo/Y1” of the MBE/AEPF. The VSTB will turn on the blower motor and the motor will ramp up to 60% of the speed programmed in the motor based on the settings of dip switch 1 and 2. The VSTB will supply 24Vac to “Y” at the heat pump. **The compressor will start on low stage and outdoor fan will start on low speed on a “Y1” heating demand but the blower motor will deliver only 60% of the programmed cfm for high speed heating operation.**
- 4.2 If a thermostat that provides a “Y2” demand in heating is used and first stage heating cannot satisfy the demand, the room thermostat will energize “Y2” and supply 24Vac to “Y/Y2” of the MBE unit. The blower motor will change to the cfm for high speed heating operation and the VSTB will supply 24Vac to “Y/Y2” at the heat pump. The outdoor fan will change to high speed operation and compressor will shift to high stage. If the “Y2” demand is present and becomes satisfied, the thermostat will remove the “Y2” demand and the VSTB will remove the 24Vac from “Y/Y2” at the heat pump. The blower will drop to 60% of the programmed cfm and the outdoor fan will change to low speed. On most digital/electronic thermostats, “Y2” will remain energized until the first stage heating demand “Y1” is satisfied and then the “G”, “Y1” and “Y2” demands will be removed.
- 4.3 If the heat pump operation cannot satisfy the demand, the room thermostat energizes “W2/W3” and 24Vac is supplied to terminal “E/W1” of the VSTB inside the MBE/AEPF unit. The VSTB will supply 24Vac to heat sequencer HR1 on the electric heater assembly.
- 4.4 HR1 contacts M1 and M2 will close within 10 to 20 seconds and turn on heater element #1. At the same time, if the heater assembly contains a second heater element, HR1 will contain a second set of contacts, M3 and M4, which will close and turn on heater element #2.

Note: If more than two heater elements are on the heater assembly, it will contain a second heat sequencer, HR2, which will control the 3rd and 4th heater elements if available. **For the 3rd and 4th heater elements to operate on a second stage auxiliary heat demand, the PJ4 jumper on the VSTB inside the MBE/AEPF must be cut.** If the “W2/W3” demand cannot be satisfied by the heat pump, the temperature indoors will continue to drop. The room thermostat will then energize “W3/W4” and 24Vac will be supplied to “W/W2” of the MBE. The VSTB will supply 24Vac to HR2 on the electric heater assembly. When the “W3/W4” demand is satisfied, the room thermostat will remove the 24Vac from “W/W2” of the MBE/AEPF. The contacts on HR2 will open between 30 to 70 seconds and heater elements #3 and #4 will be turned off. **On most digital/electronic thermostats, “W3/W4” will remain energized until the first stage demand “Y1” is satisfied and then the “G”, “Y1”, “Y2”, “W2/W3” and “W3/W4” demands will be removed.**

SERVICING

4.5 As the temperature indoors increase, it will reach a point where the “W2/W3” demand is satisfied. When this happens, the room thermostat will remove the 24Vac from “E/W1” of the MBE/AEPF. The contacts on HR1 will open between 30 to 70 seconds and turn off the 1st and 2nd heater elements. If the “Y2” demand is present and becomes satisfied the room thermostat will remove the 24Vac from “Y/Y2” of the MBE and the blower motor will change to 60% of the programmed cfm. The VSTB will remove the 24Vac from “Y/Y2” at the heat pump and the outdoor fan will change to low speed operation. The heat pump remains on along with the blower motor because the “Y1” demand for first stage heat will still be present.

4.6 When the first stage heat demand “Y1” is satisfied, the room thermostat will remove the 24Vac from “G” and “Ylo/Y1” of the MBE/AEPF. The VSTB removes the 24Vac from “Ylo/Y1” at the heat pump and the compressor and outdoor fan are turned off. The blower motor will ramp down to a complete stop based on the time and rate programmed in the motor control.

5.0 Defrost Operation

On heat pump units, when the room thermostat is set to the heating mode, the reversing valve is not energized. As long as the thermostat is set for heating, the reversing valve will be in the de-energized position for heating except during a defrost cycle.

5.1 The heat pump will be on and operating in the heating mode as described the Heating Operation in section 4.

5.2 The defrost control in the heat pump unit checks to see if a defrost is needed every 30, 60 or 90 minutes of heat pump operation depending on the selectable setting by monitoring the state of the defrost thermostat attached to the outdoor coil.

5.3 If the temperature of the outdoor coil is low enough to cause the defrost thermostat to be closed when the defrost board checks it, the board will initiate a defrost cycle.

5.4 When a defrost cycle is initiated, the contacts of the HVDR relay on the defrost board open and turns off the outdoor fan. The contacts of the LVDR relay on the defrost board closes and supplies 24Vac to “O” and “W2”. The reversing valve is energized and the contacts on HR1 close and turns on the electric heater(s). The unit will continue to run in this mode until the defrost cycle is completed.

a. For models with defrost control PCBDM133 or PCBDM160, a 30 second compressor delay at defrost initiation/termination is optional. As shipped from the factory, the control is set for the delay (“DLY”), which will turn the compressor off for 30 seconds while the reversing valve shifts to/from the cooling mode position. To bypass the delay, which typically reduces sound levels during defrost mode, change the pin settings from “DLY” to “NORM”.

5.5 When the temperature of the outdoor coil rises high enough to causes the defrost thermostat to open, the defrost cycle will be terminated. If at the end of the programmed 10 minute override time the defrost thermostat is still closed, the defrost board will automatically terminate the defrost cycle.

S-50 CHECKING HEATER LIMIT CONTROL(S)

(OPTIONAL ELECTRIC HEATERS)

Each individual heater element is protected with an automatic reset limit control connected in series with each element to prevent overheating of components in case of low airflow. This limit control will open its circuit at approximately 150°F. to 160°F and close at approximately 110°F.



WARNING

Disconnect ALL power before servicing.

1. Remove the wiring from the control terminals.
2. Using an ohmmeter test for continuity across the normally closed contacts. No reading indicates the control is open - replace if necessary. Make sure the limits are cool before testing.

IF FOUND OPEN - REPLACE - DO NOT WIRE AROUND.

S-52 CHECKING HEATER ELEMENTS

Optional electric heaters may be added, in the quantities shown in the spec sheet for each model unit, to provide electric resistance heating. Under no condition shall more heaters than the quantity shown be installed.



WARNING

HIGH VOLTAGE!

Disconnect ALL power before servicing or installing. Multiple power sources may be present. Failure to do so may cause property damage, personal injury or death.



1. Disassemble and remove the heating element(s).
2. Visually inspect the heater assembly for any breaks in the wire or broken insulators.
3. Using an ohmmeter, test the element for continuity - no reading indicates the element is open. Replace as necessary.

S-60 ELECTRIC HEATER (OPTIONAL ITEM)

Optional electric heaters may be added, in the quantities shown in the specifications section, to provide electric resistance heating. Under no condition shall more heaters than the quantity shown be installed.

The low voltage circuit in the air handler is factory wired and terminates at the location provided for the electric heater(s). A minimum of field wiring is required to complete the installation.

Other components such as a Heating/Cooling Thermostat and Outdoor Thermostats are available to complete the installation.

The system CFM can be determined by measuring the static pressure external to the unit. The installation manual supplied with the blower coil, or the blower performance table in the service manual, shows the CFM for the static measured.

SERVICING

Alternately, the system CFM can be determined by operating the electric heaters and indoor blower WITHOUT having the compressor in operation. Measure the temperature rise as close to the blower inlet and outlet as possible.

If other than a 240V power supply is used, refer to the **BTUH CAPACITY CORRECTION FACTOR** chart below.

BTUH CAPACITY CORRECTION FACTOR				
SUPPLY VOLTAGE	250	230	220	208
MULTIPLICATION FACTOR	1.08	.92	.84	.75

EXAMPLE: Five (5) heaters provide 24.0KW at the rated 240V. Our actual measured voltage is 220V, and our measured temperature rise is 42°F. Find the actual CFM:

Answer: 24.0KW, 42°F Rise, 240V = 1800CFM from the **TEMPERATURE RISE** chart on the right.

Heating output at 220 V = 24.0KW x 3.413 x .84 = 68.8 MBH.

Actual CFM = 1800 x .84 Corr. Factor = 1400 CFM.

NOTE: The temperature rise table is for sea level installations. The temperature rise at a particular KW and CFM will be greater at high altitudes, while the external static pressure at a particular CFM will be less.

TEMPERATURE RISE (°F) @ 240V								
CFM	3.0 kW	4.8 kW	7.2 kW	9.6 kW	14.4 kW	19.2 kW	24.0 kW	28.8 kW
600	16	25	38	51	-	-	-	-
700	14	22	33	43	-	-	-	-
800	12	19	29	38	57	-	-	-
900	11	17	26	34	51	-	-	-
1000	10	15	23	30	46	-	-	-
1100	9	14	21	27	41	55	-	-
1200	8	13	19	25	38	50	-	-
1300	7	12	18	23	35	46	-	-
1400	7	11	16	22	32	43	54	65
1500	6	10	15	20	30	40	50	60
1600	6	9	14	19	28	38	47	57
1700	6	9	14	18	27	36	44	53
1800	5	8	13	17	25	34	42	50
1900	5	8	12	16	24	32	40	48
2000	5	8	12	15	23	30	38	45
2100	5	7	11	14	22	29	36	43
2200	4	7	11	14	21	27	34	41
2300	4	7	10	13	20	26	33	39

ELECTRIC HEATER CAPACITY BTUH								
HTR KW	3.0 KW	4.7 KW	6.0 KW	7.0 KW	9.5 KW	14.2 KW	19.5 KW	21.0 KW
BTUH	10200	16200	20400	23800	32400	48600	66500	71600

FORMULAS:

$$\text{Heating Output} = \text{KW} \times 3413 \times \text{Corr. Factor}$$

$$\text{Actual CFM} = \text{CFM (from table)} \times \text{Corr. Factor}$$

$$\text{BTUH} = \text{KW} \times 3413$$

$$\text{BTUH} = \text{CFM} \times 1.08 \times \text{Temperature Rise (T)}$$

$$\text{CFM} = \frac{\text{KW} \times 3413}{1.08 \times T}$$

$$T = \frac{\text{BTUH}}{\text{CFM} \times 1.08}$$

S-61A CHECKING HEATER LIMIT CONTROL(S)

Each individual heater element is protected with a limit control device connected in series with each element to prevent overheating of components in case of low airflow. This limit control will open its circuit at approximately 150°F.



WARNING

HIGH VOLTAGE!
Disconnect ALL power before servicing or installing. Multiple power sources may be present. Failure to do so may cause property damage, personal injury or death.



1. Remove the wiring from the control terminals.
2. Using an ohmmeter, test for continuity across the normally closed contacts. No reading indicates the control is open - replace if necessary.

IF FOUND OPEN - REPLACE - DO NOT WIRE AROUND.

S-61B CHECKING HEATER FUSE LINK

(OPTIONAL ELECTRIC HEATERS)

Each individual heater element is protected with a one time fuse link which is connected in series with the element. The fuse link will open at approximately 333°.



WARNING

Disconnect ALL power before servicing.

1. Remove heater element assembly so as to expose fuse link.
2. Using an ohmmeter, test across the fuse link for continuity - no reading indicates the link is open. Replace as necessary.

NOTE: The link is designed to open at approximately 333°F. DO NOT WIRE AROUND - determine reason for failure.

SERVICING

S-62 CHECKING HEATER ELEMENTS



WARNING

Disconnect ALL power before servicing.

1. Disassemble and remove the heating element.
2. Visually inspect the heater assembly for any breaks in the wire or broken insulators.
3. Using an ohmmeter, test the element for continuity - no reading indicates the element is open. Replace as necessary.

S-100 REFRIGERATION REPAIR PRACTICE



DANGER

Always remove the refrigerant charge in a proper manner before applying heat to the system.

When repairing the refrigeration system:



WARNING

HIGH VOLTAGE!

Disconnect ALL power before servicing or installing. Multiple power sources may be present. Failure to do so may cause property damage, personal injury or death.



1. Never open a system that is under vacuum. Air and moisture will be drawn in.
2. Plug or cap all openings.
3. Remove all burrs and clean the brazing surfaces of the tubing with sand cloth or paper. Brazing materials do not flow well on oxidized or oily surfaces.
4. Clean the inside of all new tubing to remove oils and pipe chips.
5. When brazing, sweep the tubing with dry nitrogen to prevent the formation of oxides on the inside surfaces.
6. Complete any repair by replacing the liquid line drier in the system, evacuate and charge.

BRAZING MATERIALS

IMPORTANT NOTE: Torch heat required to braze tubes of various sizes is proportional to the size of the tube. Tubes of smaller size require less heat to bring the tube to brazing temperature before adding brazing alloy. Applying too much heat to any tube can melt the tube. Service personnel must use the appropriate heat level for the size of the tube being brazed.

NOTE: The use of a heat shield when brazing is recommended to avoid burning the serial plate or the finish on the unit. Heat trap or wet rags should be used to protect heat sensitive components such as service valves and TXV valves.

Copper to Copper Joints - Sil-Fos used without flux (alloy of 15% silver, 80% copper, and 5% phosphorous). Recommended heat 1400°F.

Copper to Steel Joints - Silver Solder used without a flux (alloy of 30% silver, 38% copper, 32% zinc). Recommended heat - 1200°F.

S-101 LEAK TESTING (NITROGEN OR NITROGEN-TRACED)



WARNING

To avoid the risk of fire or explosion, never use oxygen, high pressure air or flammable gases for leak testing of a refrigeration system.



WARNING

To avoid possible explosion, the line from the nitrogen cylinder must include a pressure regulator and a pressure relief valve. The pressure relief valve must be set to open at no more than 150 psig.

Pressure test the system using dry nitrogen and soapy water to locate leaks. If you wish to use a leak detector, charge the system to 10 psi using the appropriate refrigerant then use nitrogen to finish charging the system to working pressure, then apply the detector to suspect areas. If leaks are found, repair them. After repair, repeat the pressure test. If no leaks exist, proceed to system evacuation.

S-102 EVACUATION



WARNING

**REFRIGERANT UNDER PRESSURE!
Failure to follow proper procedures may cause property damage, personal injury or death.**



WARNING

Do not front seat the service valve(s) with the compressor open, with the suction line of the compressor closed or severely restricted.

IMPORTANT NOTE: Because of the potential damage to compressors, do not allow suction pressure at service valve to drop below 20 PSIG when pumping unit system down for repair. Outdoor section, depending on line set length and amount of charge in system, may not be able to hold the entire system charge.

SERVICING

This is the most important part of the entire service procedure. The life and efficiency of the equipment is dependent upon the thoroughness exercised by the serviceman when evacuating air (non-condensables) and moisture from the system. Air in a system causes high condensing temperature and pressure, resulting in increased power input and reduced performance. Moisture chemically reacts with the refrigerant oil to form corrosive acids. These acids attack motor windings and parts, causing breakdown. The equipment required to thoroughly evacuate the system is a high vacuum pump, capable of producing a vacuum equivalent to 250 microns or less and a vacuum gauge to give a true reading of the vacuum in the system.

NOTE: *Never use the Scroll compressor as a vacuum pump or run when under a high vacuum. Motor damage could occur.*

Condensing unit liquid and suction valves are closed to contain the charge within the unit. The unit is shipped with the valve stems closed and caps installed. **Do not open valves until the system is evacuated.**

1. Connect the vacuum pump with 250 micron capability to the service valves.
2. Evacuate the system to 250 microns or less using suction **and** liquid service valves. Using both valves is necessary as some compressors create a mechanical seal separating the sides of the system.
3. Close pump valve and hold vacuum for 10 minutes. Typically pressure will rise during this period.
4. If the pressure rises to 1000 microns or less and remains steady the system is considered leak free; proceed to startup.
5. If pressure rises above 1000 microns but holds steady below 2000 microns, moisture and/or non-condensibles may be present or the system may have a small leak.
6. Return to step 2: If the same result is encountered check for leaks as previously indicated and repair as necessary then repeat evacuation.
7. If pressure rises above 2000 microns, a leak is present. Check for leaks as previously indicated and repair as necessary then repeat evacuation.

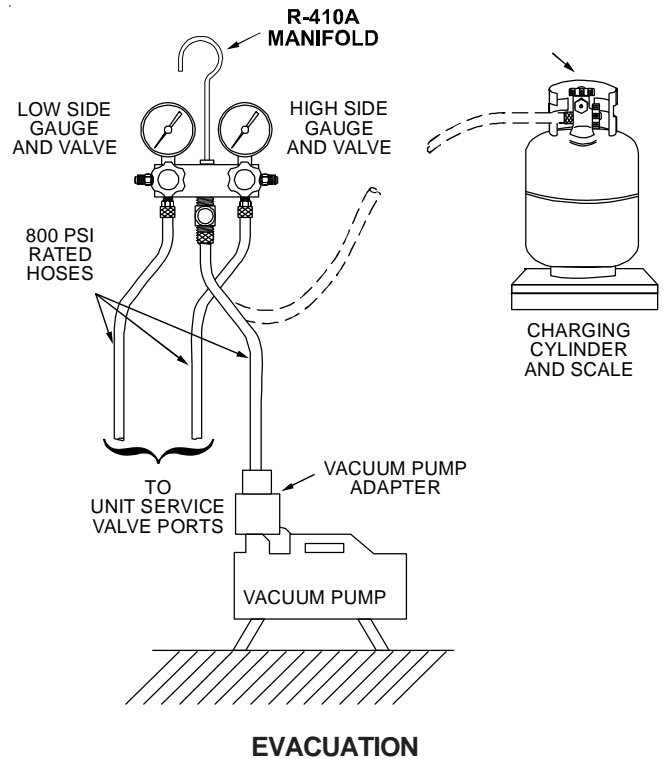

S-103 CHARGING



WARNING

REFRIGERANT UNDER PRESSURE!

* Do not overcharge system with refrigerant.

* Do not operate unit in a vacuum or at negative pressure.

Failure to follow proper procedures may cause property damage, personal injury or death.



CAUTION

Use refrigerant certified to AHRI standards. Used refrigerant may cause compressor damage and is not covered under the warranty. Most portable machines cannot clean used refrigerant to meet AHRI standards.



CAUTION

Damage to the unit caused by operating the compressor with the suction valve closed is not covered under the warranty and may cause serious compressor damage.

SERVICING

Charge the system with the exact amount of refrigerant. Refer to the specification section or check the unit nameplates for the correct refrigerant charge. An inaccurately charged system will cause future problems.

NOTE: R410A should be drawn out of the storage container or drum in liquid form due to its fractionation properties, but should be “Flashed” to its gas state before entering the system. There is commercially available restriction devices that fit into the system charging hose set to accomplish this. **DO NOT charge liquid R410A into the compressor.**

NOTE: Power must be supplied to the 18 SEER outdoor units containing ECM motors before the power is applied to the indoor unit. Sending a low voltage signal without high voltage power present at the outdoor unit can cause malfunction of the control module on the ECM motor.

Adequate refrigerant charge for the matching evaporator coil or air handler and 15 feet of line set is supplied with the condensing unit. If using evaporator coils or air handlers other than HSVTC coil it may be necessary to add or remove refrigerant to attain proper charge. If line set exceeds 15 feet in length, refrigerant should be added at .6 ounces per foot of liquid line.

NOTE: The outdoor temperature should be 60°F or higher when charging the unit. Charge should always be checked using subcooling when using TXV equipped indoor coil to verify proper charge. **Open the suction service valve first!** If the liquid service valve is opened first, oil from the compressor may be drawn into the indoor coil TXV, restricting refrigerant flow and affecting operation of the system.

When opening valves with retainers, open each valve only until the top of the stem is 1/8" from the retainer. To avoid loss of refrigerant, DO NOT apply pressure to the retainer. When opening valves without a retainer remove service valve cap and insert a hex wrench into the valve stem and back out the stem by turning the hex wrench counterclockwise. Open the valve until it contacts the rolled lip of the valve body.

NOTE: These are not back-seating valves. It is not necessary to force the stem tightly against the rolled lip.

After the refrigerant charge has bled into the system, open the liquid service valve. The service valve cap is the secondary seal for the valve and must be properly tightened to prevent leaks. Make sure cap is clean and apply refrigerant oil to threads and sealing surface on inside of cap. Tighten cap finger-tight and then tighten additional 1/6 of a turn (1 wrench flat) to properly seat the sealing surfaces.

EXPANSION VALVE SYSTEM

NOTE: Units matched with indoor coils equipped with non-adjustable TXV should be charged by subcooling only.

NOTE: The TXV should NOT be adjusted at light load conditions 55° to 60°F. Use the following guidelines and methods to check unit operation and ensure that the refrigerant charge is within limits. Charge the unit on low stage.

Units Equipped with Adjustable Expansion Valves should be charged by Subcooling and Superheat adjusted only if necessary.

1. Purge gauge lines. Connect service gauge manifold to base-valve service ports. Run the system in low stage at least 10 minutes to allow pressure to stabilize.
2. Temporarily install a thermometer on the liquid line at the liquid line service valve and 4-6" from the compressor on the suction line. Ensure the thermometer makes adequate contact and is insulated for best possible readings. Use liquid line temperature to determine subcooling and vapor temperature to determine superheat.
3. Check subcooling and superheat. Systems with TXV application should have a subcooling of 5 to 7°F and superheat of 7 to 9 °F.
 - a. If subcooling and superheat are low, adjust TXV to 7 to 9 °F superheat, and then check subcooling.

NOTE: To adjust superheat, turn the valve stem clockwise to increase and counter clockwise to decrease.

- b. If subcooling is low and superheat is high, add charge to raise subcooling to 5 to 7 °F then check superheat.
- c. If subcooling and superheat are high, adjust TXV valve to 7 to 9 °F superheat, then check subcooling.
- d. If subcooling is high and superheat is low, adjust TXV valve to 7 to 9 °F superheat and remove charge to lower the subcooling to 5 to 7 °F.

NOTE: Do NOT adjust the charge based on suction pressure unless there is a gross undercharge.

4. Disconnect manifold set, installation is complete.

SUBCOOLING FORMULA = SATURATED LIQUID TEMP. - LIQUID LINETEMP.

NOTE: Check the Schrader ports for leaks and tighten valve cores if necessary. Install caps finger-tight.

HEAT PUMP - HEATING CYCLE

The proper method of charging a heat pump in the heat mode is by weight with the additional charge adjustments for line size, line length, and other system components. For best results on outdoor units with TXVs, superheat should be 2-5°F at 4-6" from the compressor. Make final charge adjustments in the cooling cycle.

S-104 CHECKING COMPRESSOR EFFICIENCY

The reason for compressor inefficiency is broken or damaged scroll flanks on Scroll compressors, reducing the ability of the compressor to pump refrigerant vapor.

The condition of the scroll flanks is checked in the following manner.

SERVICING

1. Attach gauges to the high and low side of the system.
2. Start the system and run a "Cooling Performance Test.

If the test shows:

- a. Below normal high side pressure.
- b. Above normal low side pressure.
- c. Low temperature difference across coil.
- d. Low amp draw at compressor.

And the charge is correct. The compressor is faulty - replace the compressor.

S-106 OVERFEEDING

Overfeeding by the expansion valve results in high suction pressure, cold suction line, and possible liquid slugging of the compressor.

If these symptoms are observed:

1. Check for an overcharged unit by referring to the cooling performance charts in the servicing section.
2. Check the operation of the power element in the valve as explained in S-110 Checking Expansion Valve Operation.
3. Check for restricted or plugged equalizer tube.

S-107 UNDERFEEDING

Underfeeding by the expansion valve results in low system capacity and low suction pressures.

If these symptoms are observed:

1. Check for a restricted liquid line or drier. A restriction will be indicated by a temperature drop across the drier.
2. Check the operation of the power element of the valve as described in S-110 Checking Expansion Valve Operation.

S-108 SUPERHEAT

The expansion valves are factory adjusted to maintain 7 to 9 degrees superheat of the suction gas. Before checking the superheat or replacing the valve, perform all the procedures outlined under Air Flow, Refrigerant Charge, Expansion Valve - Overfeeding, Underfeeding. These are the most common causes for evaporator malfunction.

CHECKING SUPERHEAT

Refrigerant gas is considered superheated when its temperature is higher than the saturation temperature corresponding to its pressure. The degree of superheat equals the degrees of tempera-

ture increase above the saturation temperature at existing pressure. See Temperature - Pressure Chart on following pages.



CAUTION

To prevent personal injury, carefully connect and disconnect manifold gauge hoses. Escaping liquid refrigerant can cause burns. Do not vent refrigerant to atmosphere. Recover during system repair or final unit disposal.

1. Run system at least 10 minutes to allow pressure to stabilize.
2. For best results, temporarily install a thermometer on the liquid line at the liquid line service valve and 4-6" from the compressor on the suction line. Ensure the thermometer makes adequate contact and is insulated for best possible readings. Use liquid line temperature to determine sub-cooling and vapor temperature to determine superheat.
NOTE: An optional method is to locate the thermometer at the suction line service valve. Ensure the thermometer makes adequate contact and is insulated for best possible readings.
3. Refer to the superheat table provided for proper system superheat. Add charge to lower superheat or recover charge to raise superheat.

Superheat Formula = Suct. Line Temp. - Sat. Suct. Temp.

EXAMPLE:

- a. Suction Pressure = 143
- b. Corresponding Temp. °F. = 50
- c. Thermometer on Suction Line = 61°F.

To obtain the degrees temperature of superheat, subtract 50.0 from 61.0°F.

The difference is 11° Superheat. The 11° Superheat would fall in the ± range of allowable superheat.

SERVICING

Pressure vs. Temperature Chart							
R-410A							
PSIG	°F	PSIG	°F	PSIG	°F	PSIG	°F
12	-37.7	114.0	37.8	216.0	74.3	318.0	100.2
14	-34.7	116.0	38.7	218.0	74.9	320.0	100.7
16	-32.0	118.0	39.5	220.0	75.5	322.0	101.1
18	-29.4	120.0	40.5	222.0	76.1	324.0	101.6
20	-36.9	122.0	41.3	224.0	76.7	326.0	102.0
22	-24.5	124.0	42.2	226.0	77.2	328.0	102.4
24	-22.2	126.0	43.0	228.0	77.8	330.0	102.9
26	-20.0	128.0	43.8	230.0	78.4	332.0	103.3
28	-17.9	130.0	44.7	232.0	78.9	334.0	103.7
30	-15.8	132.0	45.5	234.0	79.5	336.0	104.2
32	-13.8	134.0	46.3	236.0	80.0	338.0	104.6
34	-11.9	136.0	47.1	238.0	80.6	340.0	105.1
36	-10.1	138.0	47.9	240.0	81.1	342.0	105.4
38	-8.3	140.0	48.7	242.0	81.6	344.0	105.8
40	-6.5	142.0	49.5	244.0	82.2	346.0	106.3
42	-4.5	144.0	50.3	246.0	82.7	348.0	106.6
44	-3.2	146.0	51.1	248.0	83.3	350.0	107.1
46	-1.6	148.0	51.8	250.0	83.8	352.0	107.5
48	0.0	150.0	52.5	252.0	84.3	354.0	107.9
50	1.5	152.0	53.3	254.0	84.8	356.0	108.3
52	3.0	154.0	54.0	256.0	85.4	358.0	108.8
54	4.5	156.0	54.8	258.0	85.9	360.0	109.2
56	5.9	158.0	55.5	260.0	86.4	362.0	109.6
58	7.3	160.0	56.2	262.0	86.9	364.0	110.0
60	8.6	162.0	57.0	264.0	87.4	366.0	110.4
62	10.0	164.0	57.7	266.0	87.9	368.0	110.8
64	11.3	166.0	58.4	268.0	88.4	370.0	111.2
66	12.6	168.0	59.0	270.0	88.9	372.0	111.6
68	13.8	170.0	59.8	272.0	89.4	374.0	112.0
70	15.1	172.0	60.5	274.0	89.9	376.0	112.4
72	16.3	174.0	61.1	276.0	90.4	378.0	112.6
74	17.5	176.0	61.8	278.0	90.9	380.0	113.1
76	18.7	178.0	62.5	280.0	91.4	382.0	113.5
78	19.8	180.0	63.1	282.0	91.9	384.0	113.9
80	21.0	182.0	63.8	284.0	92.4	386.0	114.3
82	22.1	184.0	64.5	286.0	92.8	388.0	114.7
84	23.2	186.0	65.1	288.0	93.3	390.0	115.0
86	24.3	188.0	65.8	290.0	93.8	392.0	115.5
88	25.4	190.0	66.4	292.0	94.3	394.0	115.8
90	26.4	192.0	67.0	294.0	94.8	396.0	116.2
92	27.4	194.0	67.7	296.0	95.2	398.0	116.6
94	28.5	196.0	68.3	298.0	95.7	400.0	117.0
96	29.5	198.0	68.9	300.0	96.2	402.0	117.3
98	30.5	200.0	69.5	302.0	96.6	404.0	117.7
100	31.2	202.0	70.1	304.0	97.1	406.0	118.1
102	32.2	204.0	70.7	306.0	97.5	408.0	118.5
104	33.2	206.0	71.4	308.0	98.0	410.0	118.8
106	34.1	208.0	72.0	310.0	98.4	412.0	119.2
108	35.1	210.0	72.6	312.0	98.9	414.0	119.6
110	35.5	212.0	73.2	314.0	99.3	416.0	119.9
112	36.9	214.0	73.8	316.0	99.7	418.0	120.3
						520.0	137.3

*Based on ALLIED SIGNAL Data

SERVICING

REQUIRED LIQUID LINE TEMPERATURE						
LIQUID PRESSURE AT SERVICE VALVE (PSIG)	REQUIRED SUBCOOLING TEMPERATURE (°F)					
	8	10	12	14	16	18
189	58	56	54	52	50	48
195	60	58	56	54	52	50
202	62	60	58	56	54	52
208	64	62	60	58	56	54
215	66	64	62	60	58	56
222	68	66	64	62	60	58
229	70	68	66	64	62	60
236	72	70	68	66	64	62
243	74	72	70	68	66	64
251	76	74	72	70	68	66
259	78	76	74	72	70	68
266	80	78	76	74	72	70
274	82	80	78	76	74	72
283	84	82	80	78	76	74
291	86	84	82	80	78	76
299	88	86	84	82	80	78
308	90	88	86	84	82	80
317	92	90	88	86	84	82
326	94	92	90	88	86	84
335	96	94	92	90	88	86
345	98	96	94	92	90	88
354	100	98	96	94	92	90
364	102	100	98	96	94	92
374	104	102	100	98	96	94
384	106	104	102	100	98	96
395	108	106	104	102	100	98
406	110	108	106	104	102	100
416	112	110	108	106	104	102
427	114	112	110	108	106	104
439	116	114	112	110	108	106
450	118	116	114	112	110	108
462	120	118	116	114	112	110
474	122	120	118	116	114	112
486	124	122	120	118	116	114
499	126	124	122	120	118	116
511	128	126	124	122	120	118

SERVICING

S-109 CHECKING SUBCOOLING

Refrigerant liquid is considered subcooled when its temperature is lower than the saturation temperature corresponding to its pressure. The degree of subcooling equals the degrees of temperature decrease below the saturation temperature at the existing pressure.

1. Attach an accurate thermometer or preferably a thermocouple type temperature tester to the liquid line as it leaves the condensing unit.
2. Install a high side pressure gauge on the high side (liquid) service valve at the front of the unit.
3. Record the gauge pressure and the temperature of the line.
4. Review the technical information manual or specification sheet for the model being serviced to obtain the design subcooling.
5. Compare the hi-pressure reading to the "Required Liquid Line Temperature" chart (page 108). Find the hi-pressure value on the left column. Follow that line right to the column under the design subcooling value. Where the two intersect is the required liquid line temperature.

Alternately you can convert the liquid line pressure gauge reading to temperature by finding the gauge reading in Temperature - Pressure Chart and reading to the left, find the temperature in the °F. Column.

6. The difference between the thermometer reading and pressure to temperature conversion is the amount of subcooling.

Add charge to raise subcooling. Recover charge to lower subcooling.

Subcooling Formula = Sat. Liquid Temp. - Liquid Line Temp.

EXAMPLE:

- a. Liquid Line Pressure = 417
- b. Corresponding Temp. °F. = 120°
- c. Thermometer on Liquid line = 109°F.

To obtain the amount of subcooling subtract 109°F from 120°F.

The difference is 11° subcooling. See the specification sheet or technical information manual for the design subcooling range for your unit.

S-110 CHECKING EXPANSION VALVE OPERATION

1. Remove the remote bulb of the expansion valve from the suction line.
2. Start the system and cool the bulb in a container of ice water, closing the valve. As you cool the bulb, the suction pressure should fall and the suction temperature will rise.
3. Next warm the bulb in your hand. As you warm the bulb, the suction pressure should rise and the suction temperature will fall.
4. If a temperature or pressure change is noticed, the expansion valve is operating. If no change is noticed, the valve is

restricted, the power element is faulty, or the equalizer tube is plugged.

5. Capture the charge, replace the valve and drier, evacuate and recharge.

S-112 CHECKING RESTRICTED LIQUID LINE

When the system is operating, the liquid line is warm to the touch. If the liquid line is restricted, a definite temperature drop will be noticed at the point of restriction. In severe cases, frost will form at the restriction and extend down the line in the direction of the flow.

Discharge and suction pressures will be low, giving the appearance of an undercharged unit. However, the unit will have normal to high subcooling.

Locate the restriction, replace the restricted part, replace drier, evacuate and recharge.

S-113 OVERCHARGE OF REFRIGERANT

An overcharge of refrigerant is normally indicated by an excessively high head pressure.

An evaporator coil, using an expansion valve metering device, will basically modulate and control a flooded evaporator and prevent liquid return to the compressor.

An evaporator coil, using a capillary tube metering device, could allow refrigerant to return to the compressor under extreme overcharge conditions. Also with a capillary tube metering device, extreme cases of insufficient indoor air can cause icing of the indoor coil and liquid return to the compressor, but the head pressure would be lower.

There are other causes for high head pressure which may be found in the "Service Problem Analysis Guide."

If other causes check out normal, an overcharge or a system containing non-condensables would be indicated.

If this system is observed:

1. Start the system.
2. Remove and capture small quantities of gas from the suction line dill valve until the head pressure is reduced to normal.
3. Observe the system while running a cooling performance test. If a shortage of refrigerant is indicated, then the system contains non-condensables.

SERVICING

S-114 NON-CONDENSABLES

If non-condensables are suspected, shut down the system and allow the pressures to equalize. Wait at least 15 minutes. Compare the pressure to the temperature of the coldest coil since this is where most of the refrigerant will be. If the pressure indicates a higher temperature than that of the coil temperature, non-condensables are present.

Non-condensables are removed from the system by first removing the refrigerant charge, replacing and/or installing liquid line drier, evacuating and recharging.

CHECKING COMPRESSOR EFFICIENCY

The reason for compressor inefficiency is broken or damaged scroll flanks on Scroll compressors, reducing the ability of the compressor to pump refrigerant vapor. The condition of the scroll flanks is checked in the following manner.

1. Attach gauges to the high and low side of the system.
2. Start the system and run a "Cooling Performance Test. If the test shows:
 - a. Below normal high side pressure.
 - b. Above normal low side pressure.
 - c. Low temperature difference across coil.
 - d. Low amp draw at compressor.

And the charge is correct. The compressor is faulty – replace the compressor.

S-115 COMPRESSOR BURNOUT

When a compressor burns out, high temperature develops causing the refrigerant, oil and motor insulation to decompose forming acids and sludge.

If a compressor is suspected of being burned-out, attach a refrigerant hose to the liquid line dill valve and properly remove and dispose of the refrigerant.



NOTICE

Violation of EPA regulations may result in fines or other penalties.

Now determine if a burn out has actually occurred. Confirm by analyzing an oil sample using a Sporlan Acid Test Kit, AK-3 or its equivalent.

Remove the compressor and obtain an oil sample from the suction stub. If the oil is not acidic, either a burnout has not occurred or the burnout is so mild that a complete clean-up is not necessary.

If acid level is unacceptable, the system must be cleaned by using the clean-up drier method.



CAUTION

Do not allow the sludge or oil to contact the skin. Severe burns may result.

NOTE: The Flushing Method using R-11 refrigerant is no longer approved by Amana® Brand Heating-Cooling.

Suction Line Drier Clean-Up Method

The POE oils used with R410A refrigerant is an excellent solvent. In the case of a burnout, the POE oils will remove any burnout residue left in the system. If not captured by the refrigerant filter, they will collect in the compressor or other system components, causing a failure of the replacement compressor and/or spread contaminants throughout the system, damaging additional components.

Install a field supplied suction line drier. This drier should be installed as close to the compressor suction fitting as possible. The filter must be accessible and be rechecked for pressure drop after the system has operated for a time. It may be necessary to use new tubing and form as required.

NOTE: At least twelve (12) inches of the suction line immediately out of the compressor stub must be discarded due to burned residue and contaminates.

1. Remove compressor discharge line strainer.
2. Remove the liquid line drier and expansion valve.
3. Purge all remaining components with dry nitrogen or carbon dioxide until clean.
4. Install new components **including** liquid line drier.
5. Braze all joints, leak test, evacuate, and recharge system.
6. Start up the unit and record the pressure drop across the drier.
7. Continue to run the system for a minimum of twelve (12) hours and recheck the pressure drop across the drier. Pressure drop should not exceed 6 PSIG.
8. Continue to run the system for several days, repeatedly checking pressure drop across the suction line drier. If the pressure drop never exceeds the 6 PSIG, the drier has trapped the contaminants. Remove the suction line drier from the system.
9. If the pressure drop becomes greater, then it must be replaced and steps 5 through 9 repeated until it does not exceed 6 PSIG.

NOTICE: Regardless, the cause for burnout must be determined and corrected before the new compressor is started.

SERVICING

S-120 REFRIGERANT PIPING

The piping of a refrigeration system is very important in relation to system capacity, proper oil return to compressor, pumping rate of compressor and cooling performance of the evaporator.

POE oils maintain a consistent viscosity over a large temperature range which aids in the oil return to the compressor; however, there will be some installations which require oil return traps. These installations should be avoided whenever possible, as adding oil traps to the refrigerant lines also increases the opportunity for debris and moisture to be introduced into the system. Avoid long running traps in horizontal suction line.

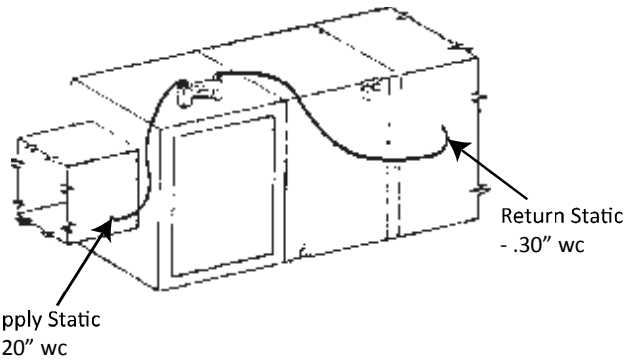

S-201 CLEANING ALUMINUM COILS

This unit is equipped with an aluminum tube evaporator coil. The safest way to clean the evaporator coil is to simply flush the coil with water. This cleaning practice remains as the recommended cleaning method for both copper tube and aluminum tube residential cooling coils.

An alternate cleaning method is to use one of the products listed in the technical publication **TP-109 (shipped in the literature bag with the unit)** to clean the coils. The cleaners listed are the only agents deemed safe and approved for use to clean round tube aluminum coils. TP-109 is available on the web site in Partner Link > Service Toolkit.

NOTE: Ensure coils are rinsed well after use of any chemical cleaners.

S-202 DUCT STATIC PRESSURES AND/OR STATIC PRESSURE DROP ACROSS COILS

This minimum and maximum allowable duct static pressure for the indoor sections are found in the specifications section.

Tables are also provided for each coil, listing quantity of air (CFM) versus static pressure drop across the coil.

Too great an external static pressure will result in insufficient air that can cause icing of the coil. Too much air can cause poor humidity control and condensate to be pulled off the evaporator coil causing condensate leakage. Too much air can also cause motor overloading and in many cases this constitutes a poorly designed system.

S-203 SINGLE PIECE AIR HANDLER EXTERNAL STATIC

To determine proper airflow, proceed as follows:

1. Using a Inclined Manometer or Magnehelic gauge , measure the static pressure of the return duct at the inlet of the air handler, this will be a negative pressure (for example-.30"wc)
2. Measure the static pressure of the supply duct at the outlet of the air handler, this should be a positive pressure (for example .20"wc).
3. Add the two readings together (for example -.30"wc + .20"wc = .50"wc total external static pressure.

NOTE: Both readings may be taken simultaneously and read directly on the manometer if so desired.

4. Consult proper air handler airflow chart for quantity of air (CFM) at the measured external static pressure.

S-203A TWO PIECE AIR HANDLER EXTERNAL STATIC PRESSURE

To determine proper airflow, proceed as follows:

1. Using a Inclined Manometer or Magnehelic gauge, measure the static pressure between the outlet of the evaporator coil and the inlet of the air handler, this will be a negative pressure (for example -.30"wc)
 2. Measure the static pressure of the supply duct at the outlet of the unit, this should be a positive pressure (for example .20"wc).
 3. Add the two readings together (for example -.30"wc + .20"wc = .50"wc total static pressure.
- NOTE:** Both readings may be taken simultaneously and read directly on the manometer if so desired.
4. Consult proper air handler airflow chart for quantity of air (CFM) at the measured external static pressure.

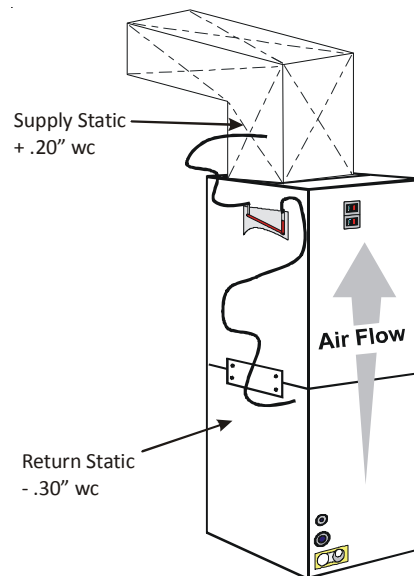

SERVICING

S-204 COIL STATIC PRESSURE DROP

1. Using a draft gauge (inclined manometer), connect the positive probe underneath the coil and the negative probe above the coil.
2. A direct reading can be taken of the static pressure drop across the coil.
3. Consult proper table for quantity of air.

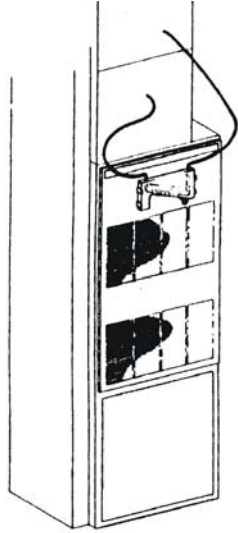

STATIC PRESSURE DROP

If the total external static pressure and/or static pressure drop exceeds the maximum or minimum allowable statics, check for closed dampers, dirty filters, undersized or poorly laid out duct work.

ACCESSORIES WIRING DIAGRAMS



WARNING

HIGH VOLTAGE!
DISCONNECT ALL POWER BEFORE SERVICING OR INSTALLING THIS UNIT. MULTIPLE POWER SOURCES MAY BE PRESENT. FAILURE TO DO SO MAY CAUSE PROPERTY DAMAGE, PERSONAL INJURY OR DEATH.



ALL FUEL SYSTEM AFE18-60A CONTROL BOARD

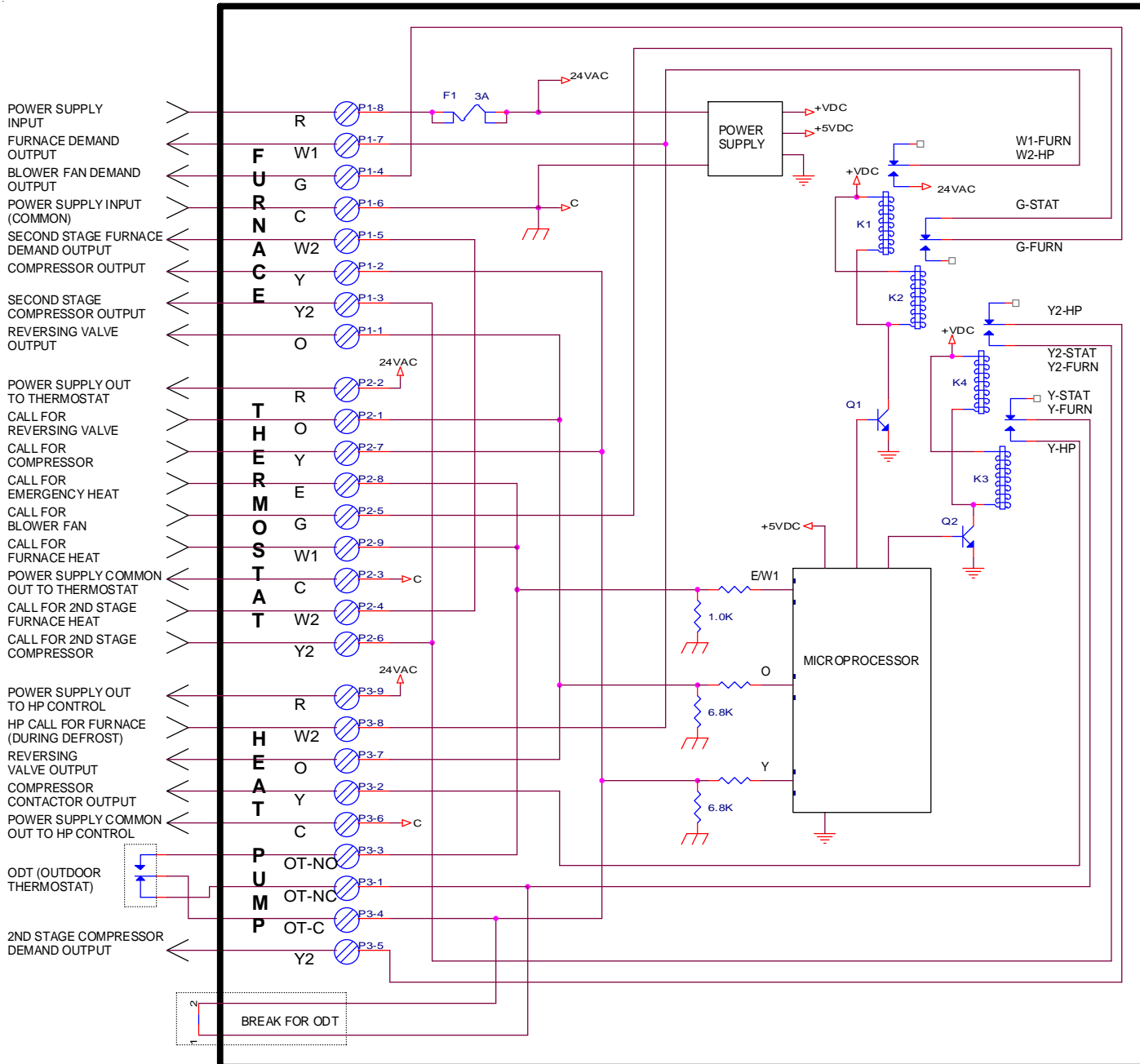

ALL FUEL CONTROL BOARD - AFE18-60A

This wiring diagram is for reference only. Not all wiring is as shown above.

Refer to the appropriate wiring diagram for the unit being serviced.

(For use with Heat Pumps in conjunction with 80% or 90% Single-Stage or Two-Stage Furnaces)

ACCESSORIES WIRING DIAGRAMS

WARNING

HIGH VOLTAGE!
 DISCONNECT ALL POWER BEFORE SERVICING OR INSTALLING THIS UNIT. MULTIPLE POWER SOURCES MAY BE PRESENT. FAILURE TO DO SO MAY CAUSE PROPERTY DAMAGE, PERSONAL INJURY OR DEATH.

10kw and Below, One Stage Electric Heat

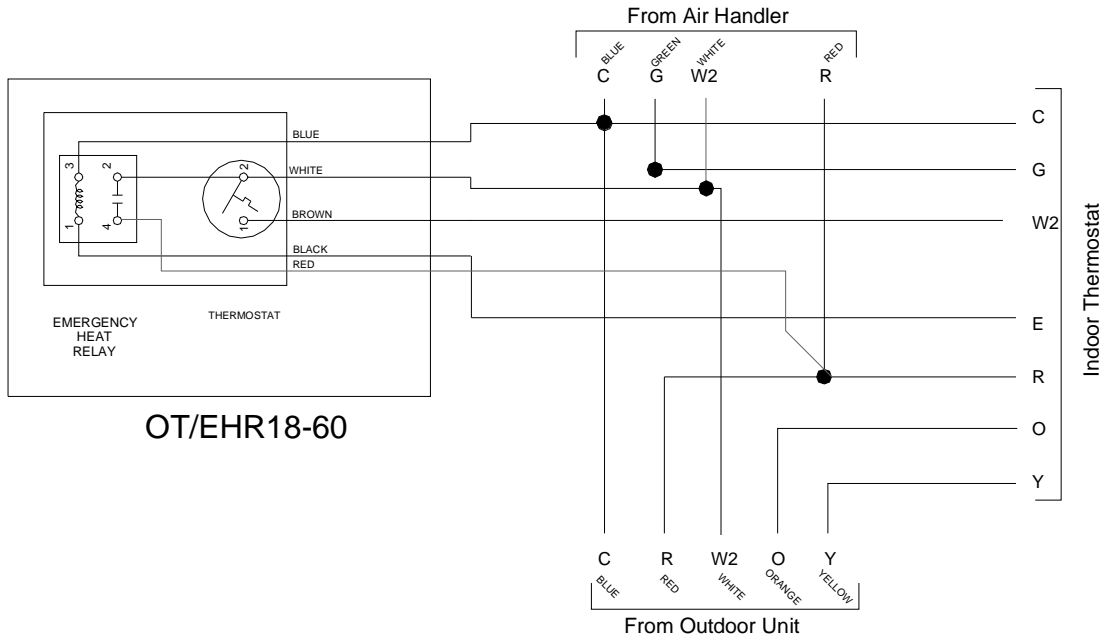

15kw and Above, Two Stage Electric Heat

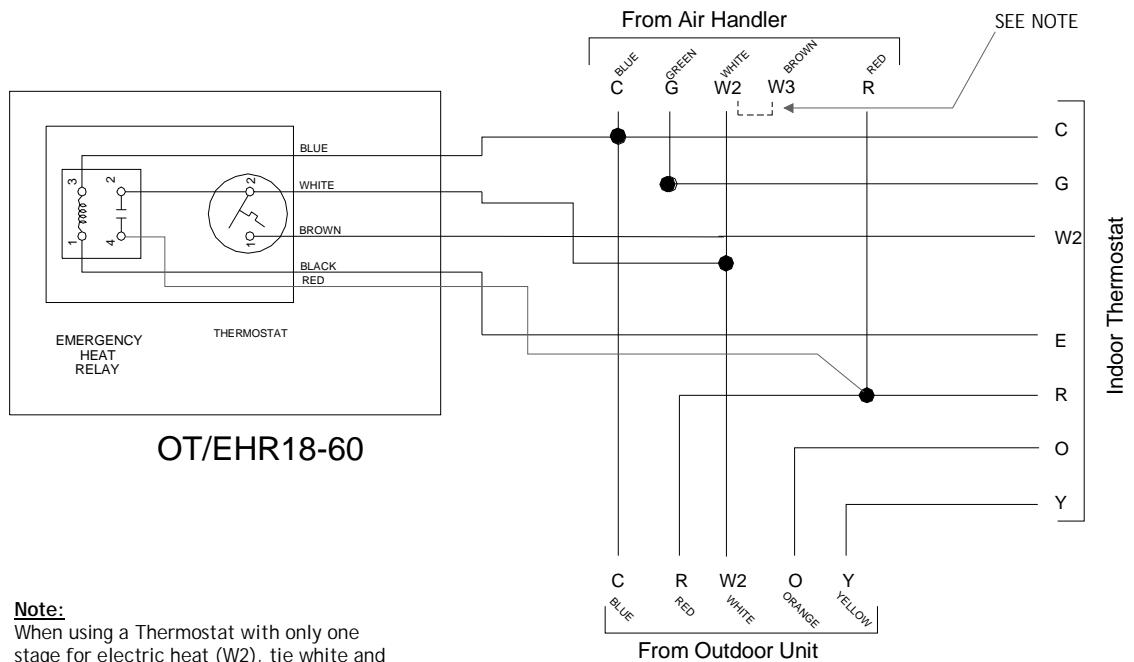

Note:
 When using a Thermostat with only one stage for electric heat (W2), tie white and brown wires from air handler together.

Typical Wiring Schematics for OT/EHR18-60 (Outdoor Thermostat & Emergency Heat Relay).
 This wiring diagram is for reference only. Not all wiring is as shown above.
 Refer to the appropriate wiring diagram for the unit being serviced.

ACCESSORIES WIRING DIAGRAMS



WARNING

HIGH VOLTAGE!
DISCONNECT ALL POWER BEFORE SERVICING OR INSTALLING THIS UNIT. MULTIPLE POWER SOURCES MAY BE PRESENT. FAILURE TO DO SO MAY CAUSE PROPERTY DAMAGE, PERSONAL INJURY OR DEATH.



15kw and Above with Two OT/EHR18-60's, Two Stage Electric Heat and Two Stage Thermostat

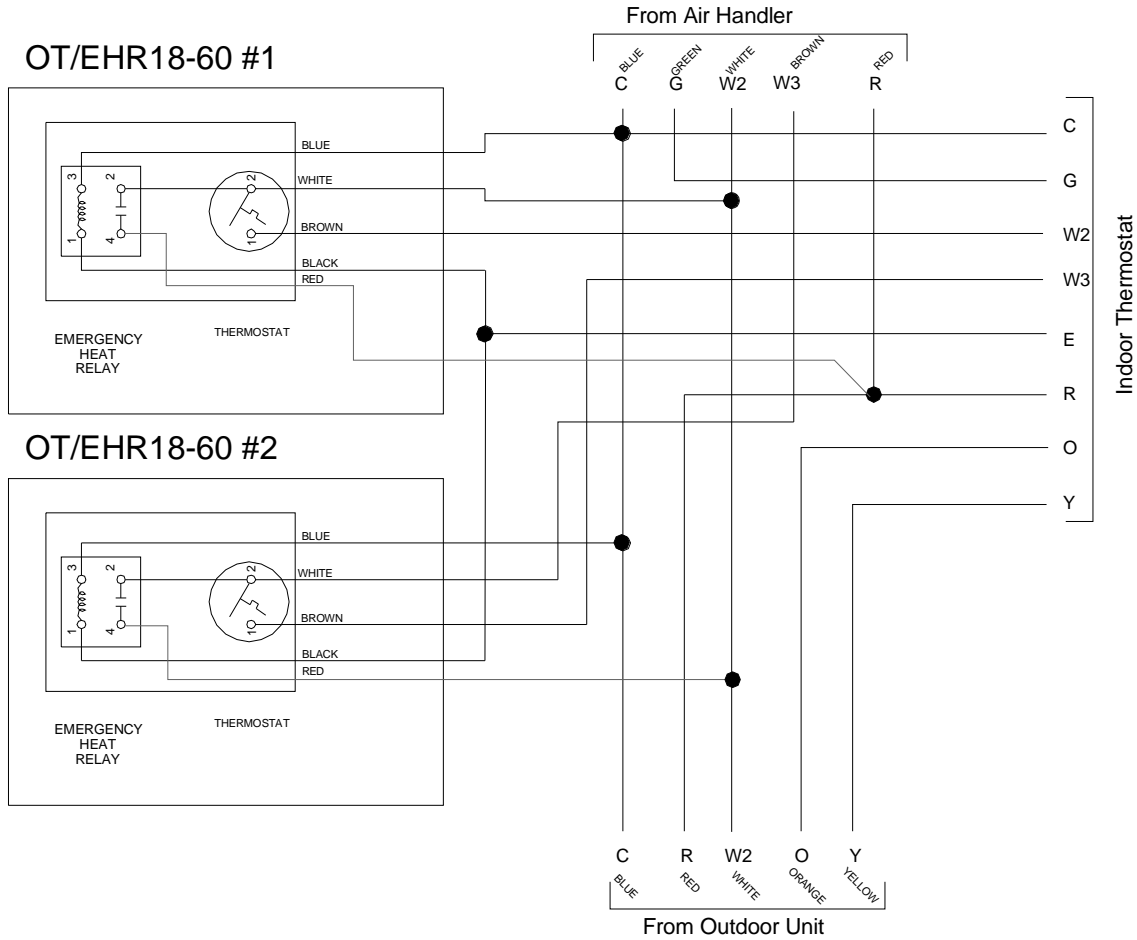

Typical Wiring Schematics for OT/EHR18-60 (Outdoor Thermostat & Emergency Heat Relay).
 This wiring diagram is for reference only. Not all wiring is as shown above.
 Refer to the appropriate wiring diagram for the unit being serviced.

ACCESSORIES WIRING DIAGRAMS

WARNING

HIGH VOLTAGE!
DISCONNECT ALL POWER BEFORE SERVICING OR INSTALLING THIS UNIT. MULTIPLE POWER SOURCES MAY BE PRESENT. FAILURE TO DO SO MAY CAUSE PROPERTY DAMAGE, PERSONAL INJURY OR DEATH.

3-Phase Heat Kit

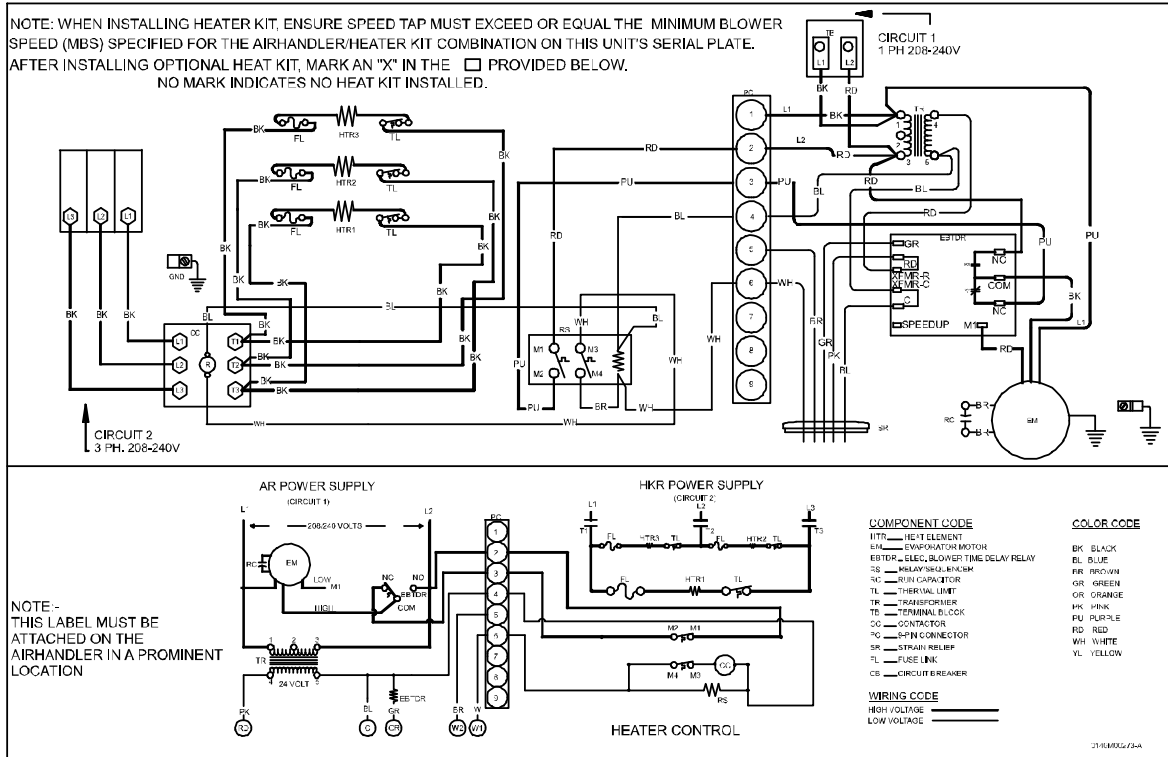

25kW Heat Kit

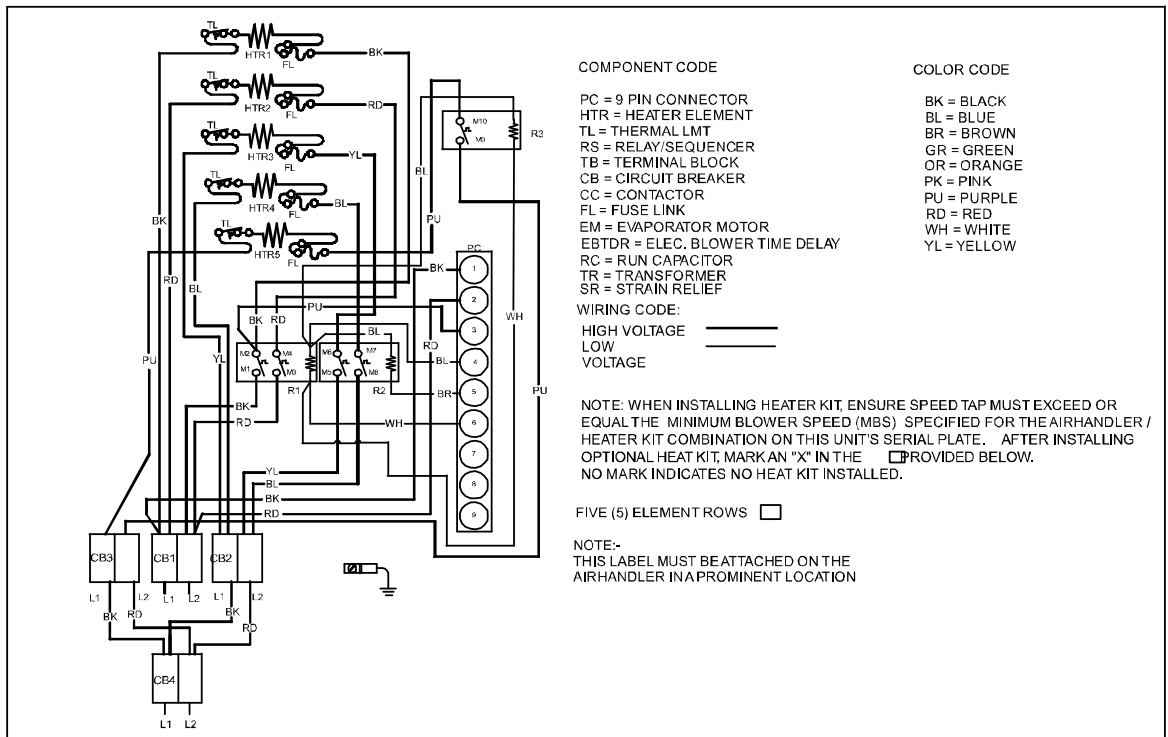

Wiring is subject to change. Always refer to the wiring diagram on the unit for the most up-to-date wiring.

AIRHANDLERS

WIRING DIAGRAMS

EFFECTIVE 12/24/14

ADPF, ARPF, ARUF, ATUF

HIGH VOLTAGE!
DISCONNECT ALL POWER BEFORE SERVICING OR INSTALLING THIS UNIT. MULTIPLE POWER SOURCES MAY BE PRESENT. FAILURE TO DO SO MAY CAUSE PROPERTY DAMAGE, PERSONAL INJURY OR DEATH.
WARNING

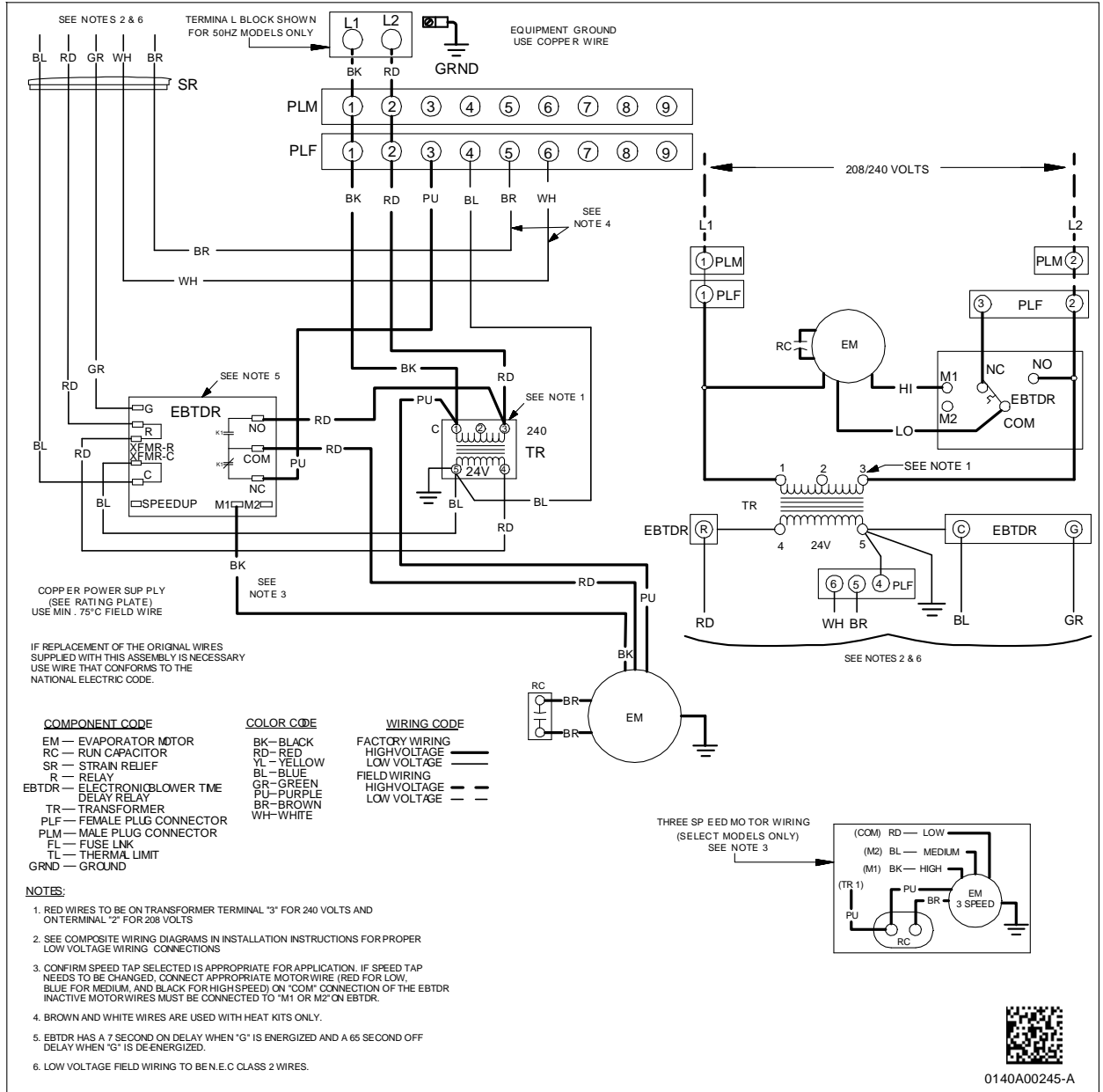

0140A00245-A

Wiring is subject to change. Always refer to the wiring diagram on the unit for the most up-to-date wiring.



HIGH VOLTAGE!
DISCONNECT ALL POWER BEFORE SERVICING OR INSTALLING THIS UNIT. MULTIPLE POWER SOURCES MAY BE PRESENT. FAILURE TO DO SO MAY CAUSE PROPERTY DAMAGE, PERSONAL INJURY OR DEATH.

WARNING

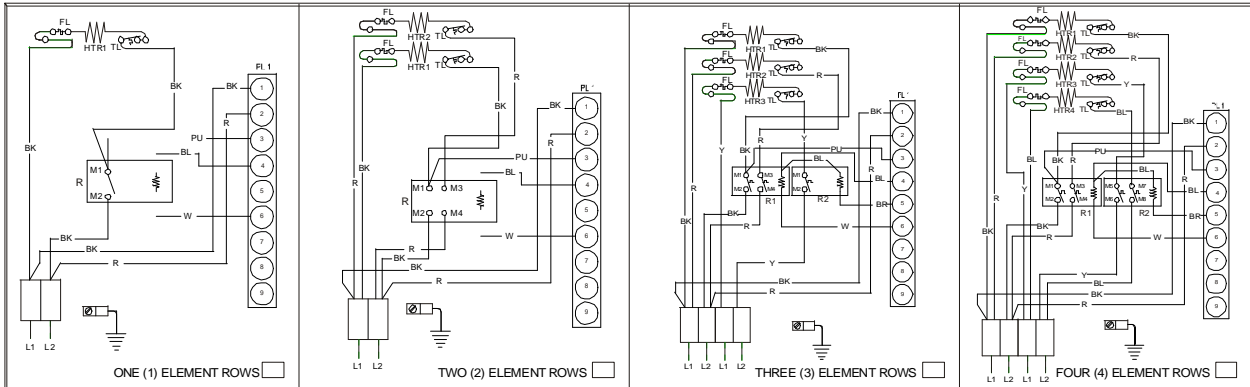

AFTER INSTALLING OPTIONAL HEAT KIT, MARK AN "X" IN THE PROVIDED ABOVE.
MARK ACCORDING TO NUMBER OF HEATER ELEMENT ROWS INSTALLED
NO MARK INDICATES NO HEAT KIT INSTALLED

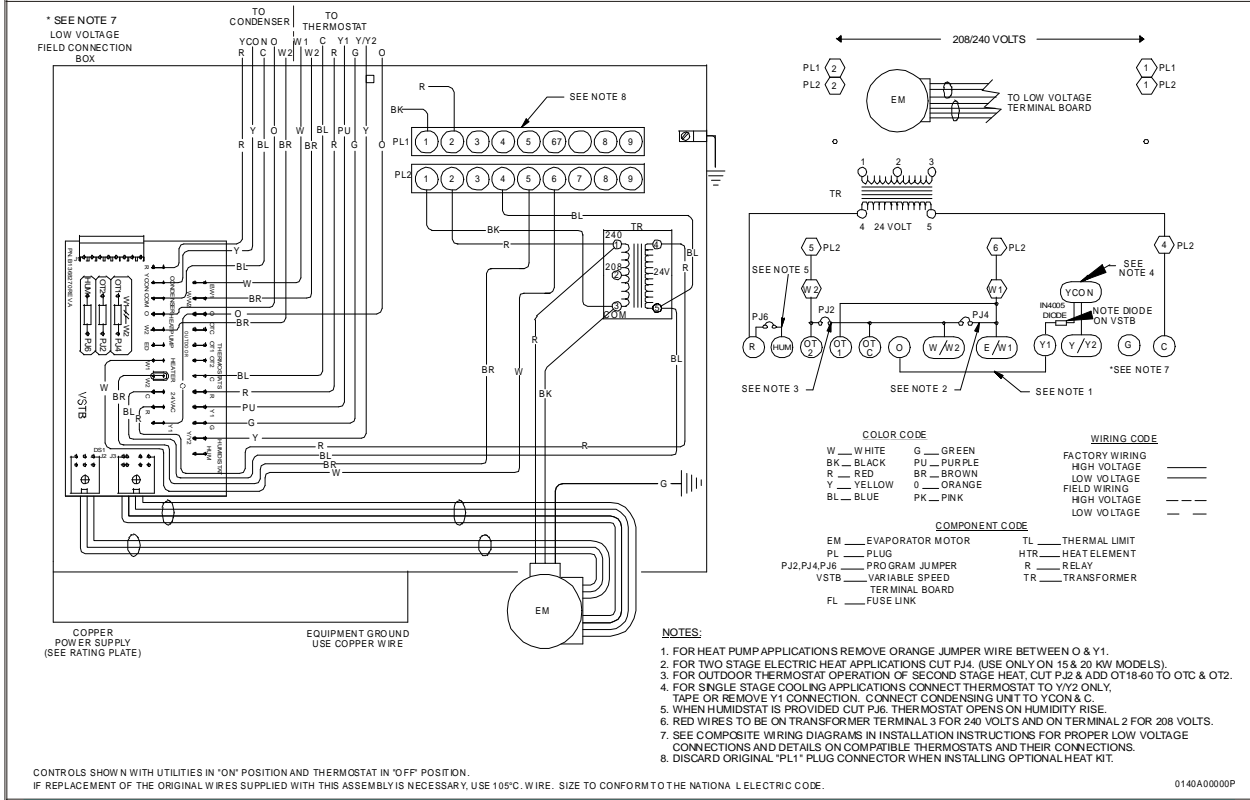



HIGH VOLTAGE!
 DISCONNECT ALL POWER BEFORE SERVICING OR INSTALLING THIS UNIT. MULTIPLE POWER SOURCES MAY BE PRESENT. FAILURE TO DO SO MAY CAUSE PROPERTY DAMAGE, PERSONAL INJURY OR DEATH.

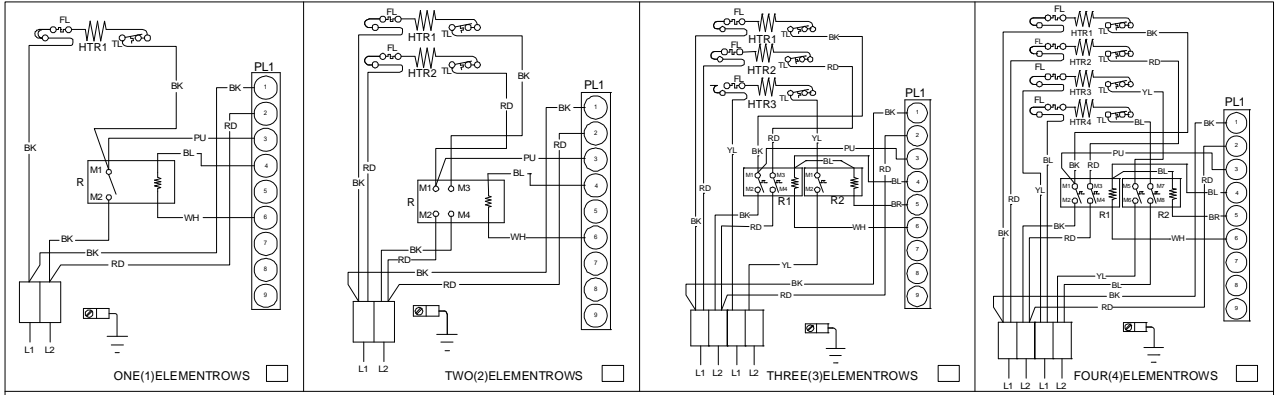

AFTER INSTALLING OPTIONAL HEAT KIT, MARK "X" IN THE PROVIDED ABOVE.
 MARK ACCORDING TO NUMBER OF HEATER ELEMENT ROWS INSTALLED.
 NO MARK INDICATES NO HEAT KIT INSTALLED.

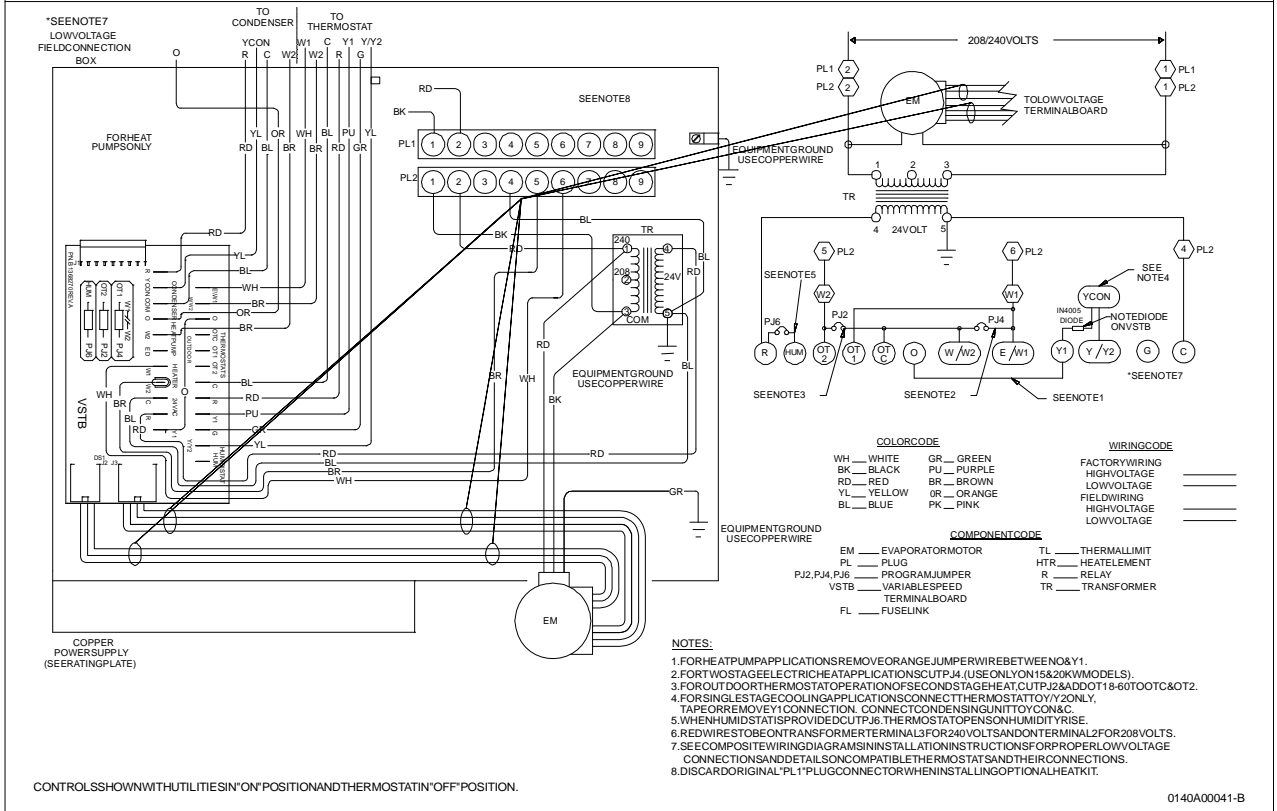



HIGH VOLTAGE!
 DISCONNECT ALL POWER BEFORE SERVICING OR INSTALLING THIS UNIT. MULTIPLE POWER SOURCES MAY BE PRESENT. FAILURE TO DO SO MAY CAUSE PROPERTY DAMAGE, PERSONAL INJURY OR DEATH.

WARNING

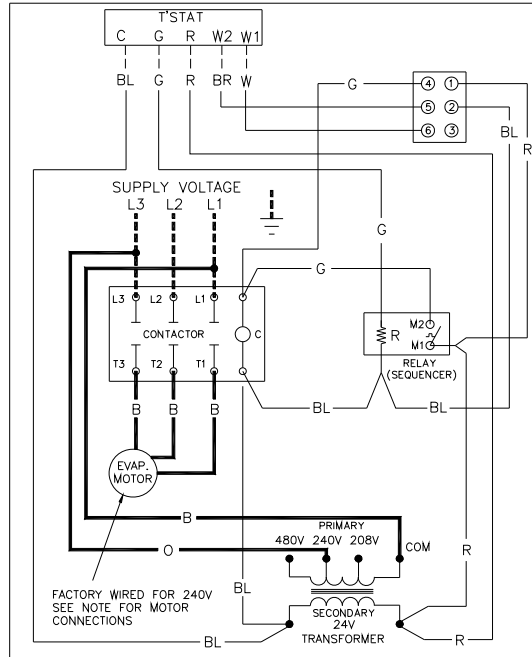

- NOTES**
- 1) ALL REPLACEMENT WIRES MUST BE SAME GAUGE AND TYPE.
 - 2) TO CHANGE VOLTAGE FROM 240V TO 208V, MOVE WIRE FROM 240V TAP TO 208V TAP AT TRANSFORMER PRIMARY.
 - 3) TO CONVERT VOLTAGE FROM 240V TO 480V:
 - a) MOVE WIRE FROM 240V TAP TO 480V TAP AT TRANSFORMER PRIMARY.
 - b) IDENTIFY MODEL (i.e. AR090 OR AR120) AND REWIRE MOTOR FROM LOW VOLTAGE (240V) TO HIGH VOLTAGE (480V) ACCORDING TO INSTRUCTION BELOW.
- COLOR CODE**
- | | |
|----|--------|
| B | BLACK |
| BL | BLUE |
| BR | BROWN |
| G | GREEN |
| O | ORANGE |
| R | RED |
| W | WHITE |
- WIRING CODE**
- | | |
|-------|----------------|
| ————— | FACTORY WIRING |
| ————— | HIGH VOLTAGE |
| ————— | LOW VOLTAGE |
| ----- | FIELD WIRING |
| ----- | HIGH VOLTAGE |
| ----- | LOW VOLTAGE |

A.O. SMITH MOTORS

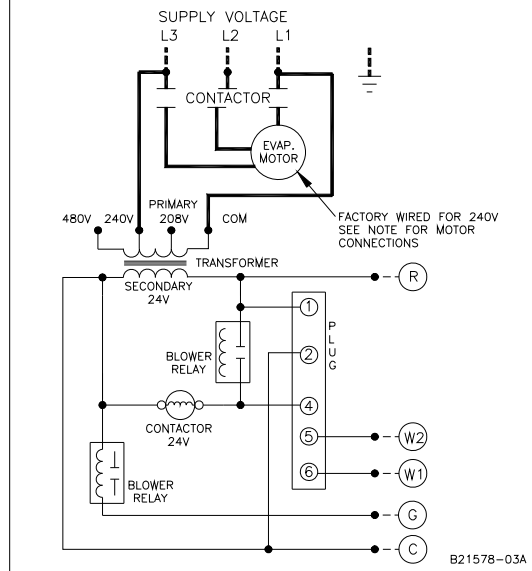
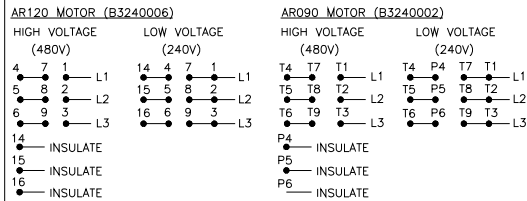

B21578-03A

Wiring is subject to change. Always refer to the wiring diagram on the unit for the most up-to-date wiring.



WARNING
HIGH VOLTAGE!
 DISCONNECT ALL POWER BEFORE SERVICING OR INSTALLING THIS UNIT. MULTIPLE POWER SOURCES MAY BE PRESENT. FAILURE TO DO SO MAY CAUSE PROPERTY DAMAGE, PERSONAL INJURY OR DEATH.

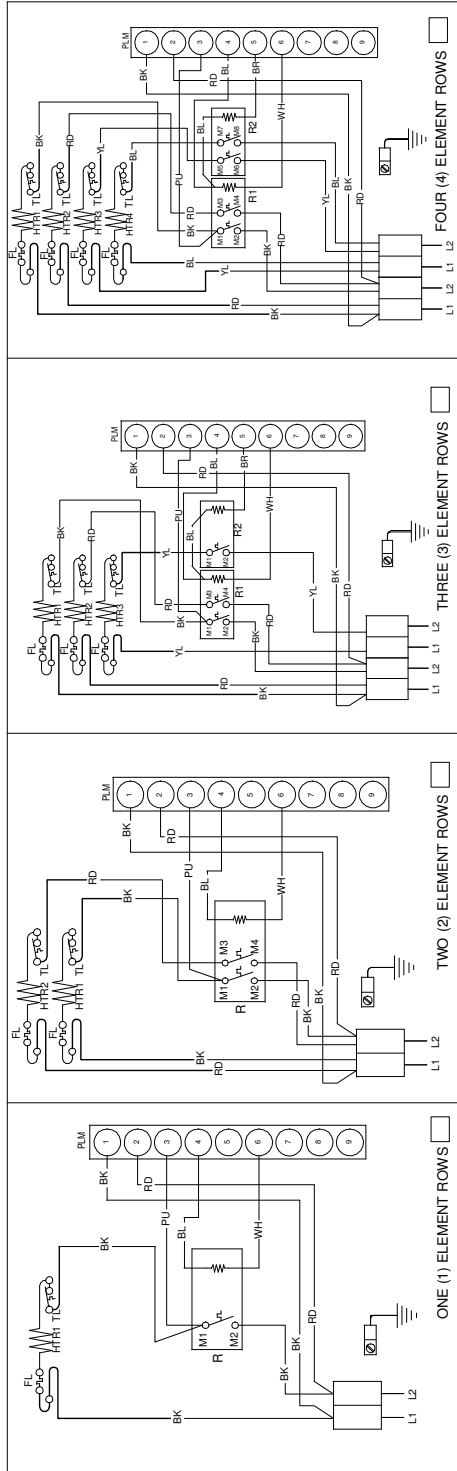

NOTE: WHEN INSTALLING HEATER KIT, ENSURE SPEED TAP DOES NOT EXCEED MINIMUM BLOWER SPEED (MBS) SPECIFIED FOR THE AIRHANDLER/HEATER KIT COMBINATION ON THIS UNIT'S S&R PLATE. AFTER INSTALLING OPTIONAL HEAT KIT, MARK AN "X" IN THE PROVIDED ABOVE. MARK ACCORDING TO NUMBER OF HEATER ELEMENT ROWS INSTALLED. NO MARK INDICATES NO HEAT KIT INSTALLED.

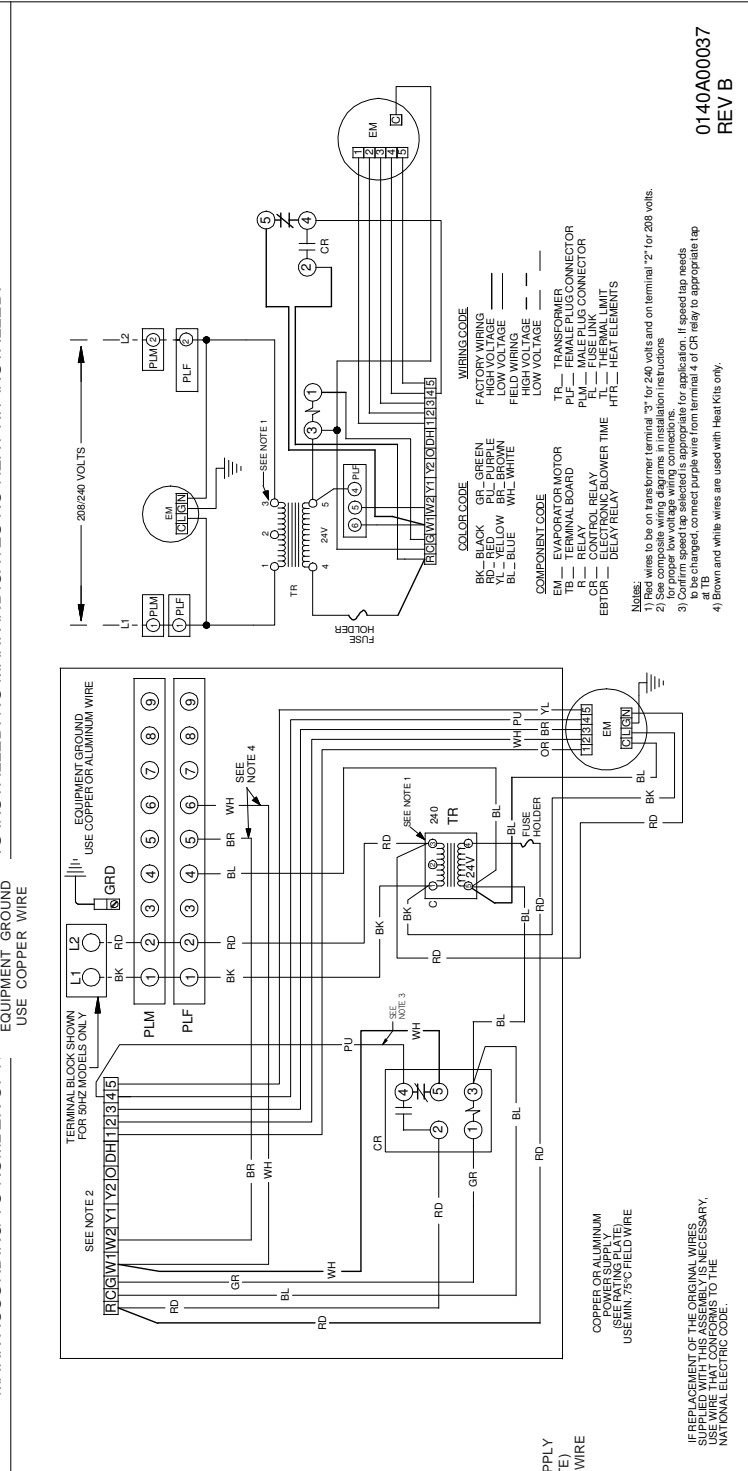

0140A00037
 REV B

COPPER POWER SUPPLY
 (SEE RATING PLATE)
 USE MIN. 75°C FIELD WIRE

IF BEAM RESISTANT OR TIE OR GALVANIZING WIRE IS SUPPLIED WITH THIS ASSEMBLY, USE WIRE THAT CONFORMS TO THE NATIONAL ELECTRIC CODE.



WARNING
HIGH VOLTAGE!
 DISCONNECT ALL POWER BEFORE SERVICING OR INSTALLING THIS UNIT. MULTIPLE POWER SOURCES MAY BE PRESENT. FAILURE TO DO SO MAY CAUSE PROPERTY DAMAGE, PERSONAL INJURY OR DEATH.

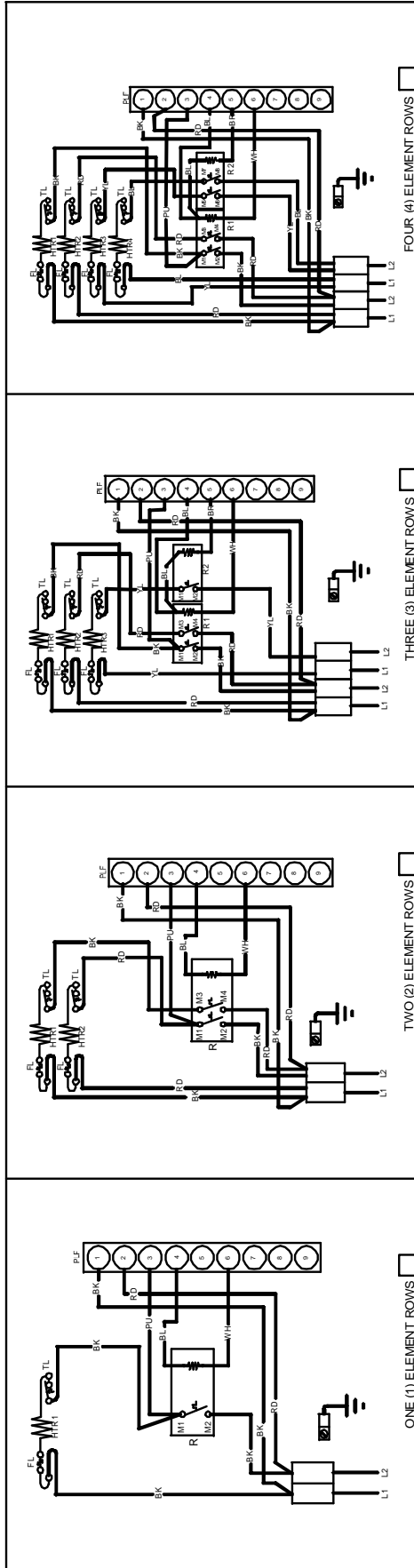

NOTE: WHEN INSTALLING HEATER KIT, ENSURE SPEED TAP DOES NOT EXCEED MINIMUM BLOWER SPEED (MBS) SPECIFIED FOR THE AIRHANDLER/HEATER KIT COMBINATION ON THIS UNIT'S S&R PLATE. AFTER INSTALLING OPTIONAL HEAT KIT, MARKA "X" IN THE BOX PROVIDED ABOVE. MARK ACCORDING TO NUMBER OF HEATER ELEMENT ROWS INSTALLED. NO MARK INDICATES NO HEAT KIT INSTALLED.

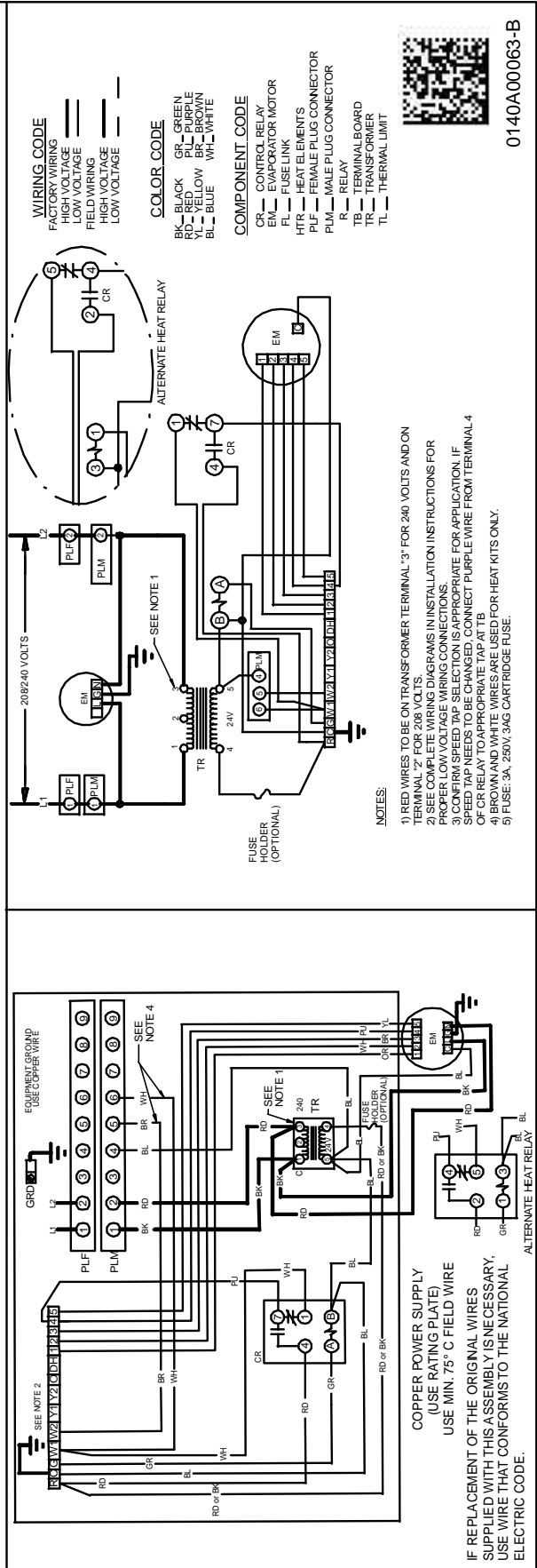

- WIRING CODE**
 FACTORY WIRING
 HIGH VOLTAGE
 LOW VOLTAGE
 FIELD WIRING
 HIGH VOLTAGE
 LOW VOLTAGE
- COLOR CODE**
 BK _ BLACK
 RD _ RED
 YL _ YELLOW
 BL _ BLUE
 GR _ GREEN
 PL _ PURPLE
 BR _ BROWN
 WH _ WHITE
- COMPONENT CODE**
 CR _ CONTROL RELAY
 EM _ EVAPORATOR MOTOR
 FL _ FUSE LINK
 HTR _ HEAT ELEMENTS
 PLF _ FEMALE PLUG CONNECTOR
 PLM _ MALE PLUG CONNECTOR
 R _ RELAY
 TB _ TERMINAL BOARD
 TR _ TRANSFORMER
 TL _ THERMAL LIMIT

- NOTES:**
- 1) RED WIRES TO BE ON TRANSFORMER TERMINAL "3" FOR 240 VOLTS AND ON TERMINAL "2" FOR 208 VOLTS
 - 2) SEE COMPLETE WIRING DIAGRAMS IN INSTALLATION INSTRUCTIONS FOR PROPER LOW VOLTAGE WIRING CONNECTIONS.
 - 3) CONFIRM SPEED TAP SELECTION IS APPROPRIATE FOR APPLICATION. IF SPEED TAP NEEDS TO BE CHANGED, CONNECT PURPLE WIRE FROM TERMINAL 4 OF CR RELAY TO APPROPRIATE TAP AT TB
 - 4) BROWN AND WHITE WIRES ARE USED FOR HEAT KITS ONLY.
 - 5) FUSE: 3A, 250V, 3/4G CARTRIDGE FUSE.



0140A00063-B

WARNING

HIGH VOLTAGE!
 DISCONNECT ALL POWER BEFORE SERVICING OR INSTALLING THIS UNIT. MULTIPLE POWER SOURCES MAY BE PRESENT. FAILURE TO DO SO MAY CAUSE PROPERTY DAMAGE, PERSONAL INJURY OR DEATH.

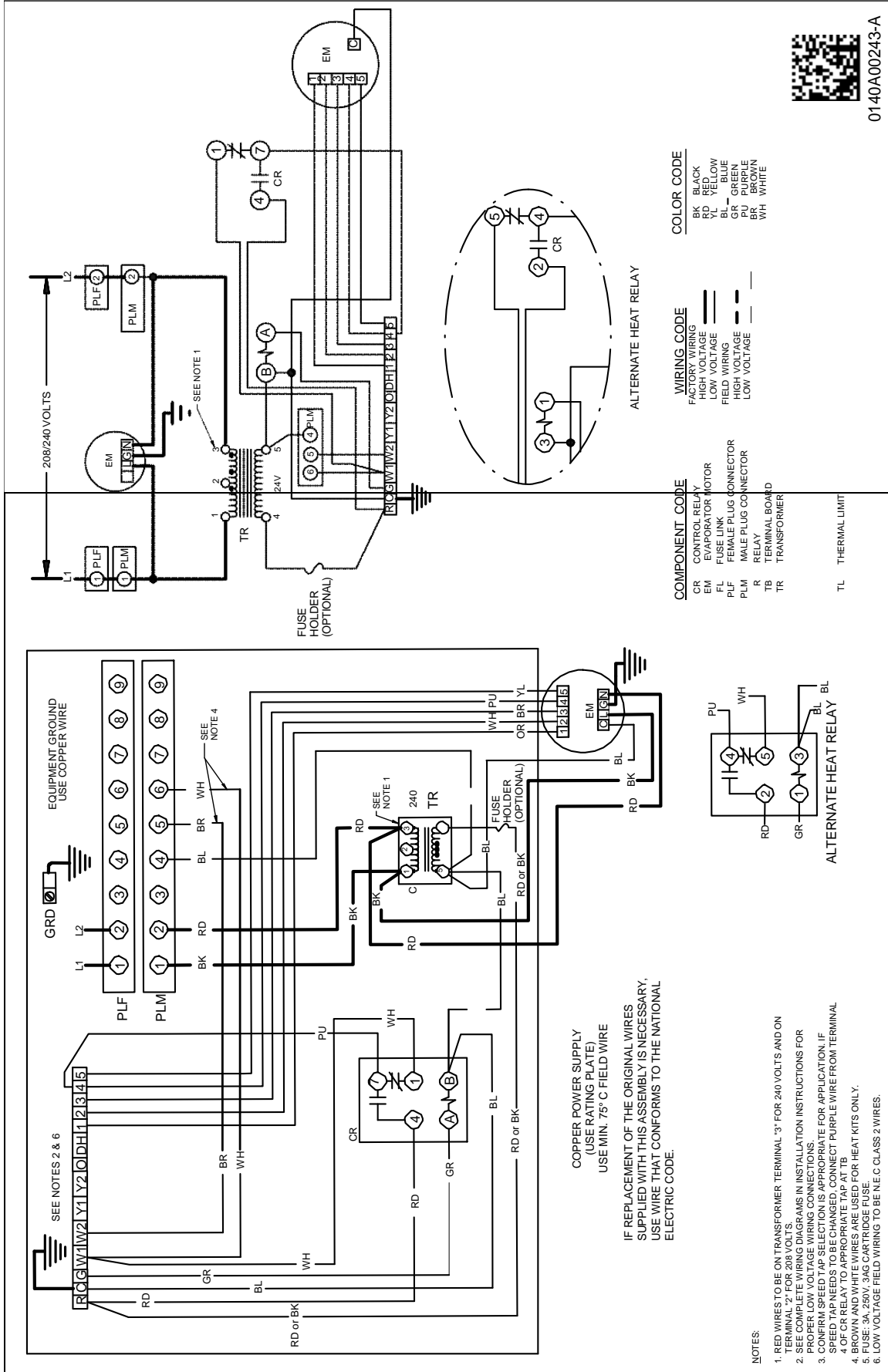

- NOTES:
1. RED WIRES TO BE ON TRANSFORMER TERMINAL "3" FOR 240 VOLTS AND ON TERMINAL "2" FOR 208 VOLTS.
 2. SEE COMPLETE WIRING DIAGRAMS IN INSTALLATION INSTRUCTIONS FOR PROPER LOW VOLTAGE WIRING CONNECTIONS.
 3. CONFIRM SPEED TAP SELECTION IS APPROPRIATE FOR APPLICATION. IF SPEED TAP NEEDS TO BE CHANGED, CONNECT PURPLE WIRE FROM TERMINAL 4 OF CR RELAY TO APPROPRIATE TAP AT TB.
 4. BROWN AND WHITE WIRES ARE USED FOR HEAT KITS ONLY.
 5. FUSE: 3A, 250V, 5AG CARTRIDGE FUSE.
 6. LOW VOLTAGE FIELD WIRING TO BE N.E.C. CLASS 2 WIRES.

Wiring is subject to change. Always refer to the wiring diagram on the unit for the most up-to-date wiring.

WIRING DIAGRAMS

ASPT**14**/ASUF**14**

3-Phase Heat Kit



WARNING
 HIGH VOLTAGE!
 DISCONNECT ALL POWER BEFORE SERVICING OR INSTALLING THIS UNIT. MULTIPLE POWER SOURCES MAY BE PRESENT. FAILURE TO DO SO MAY CAUSE PROPERTY DAMAGE, PERSONAL INJURY OR DEATH.

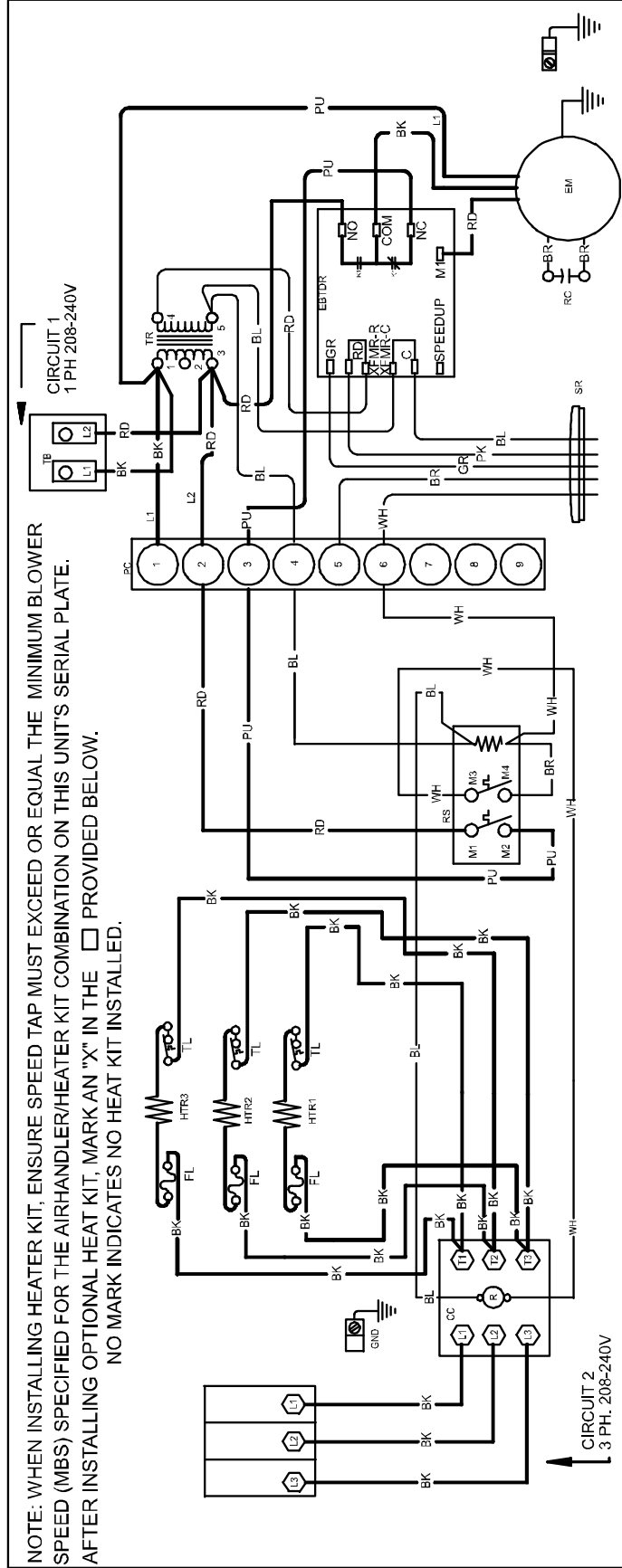

NOTE: WHEN INSTALLING HEATER KIT, ENSURE SPEED TAP MUST EXCEED OR EQUAL THE MINIMUM BLOWER SPEED (MBS) SPECIFIED FOR THE AIRHANDLER/HEATER KIT COMBINATION ON THIS UNIT'S SERIAL PLATE. AFTER INSTALLING OPTIONAL HEAT KIT, MARK AN "X" IN THE PROVIDED BELOW. NO MARK INDICATES NO HEAT KIT INSTALLED.

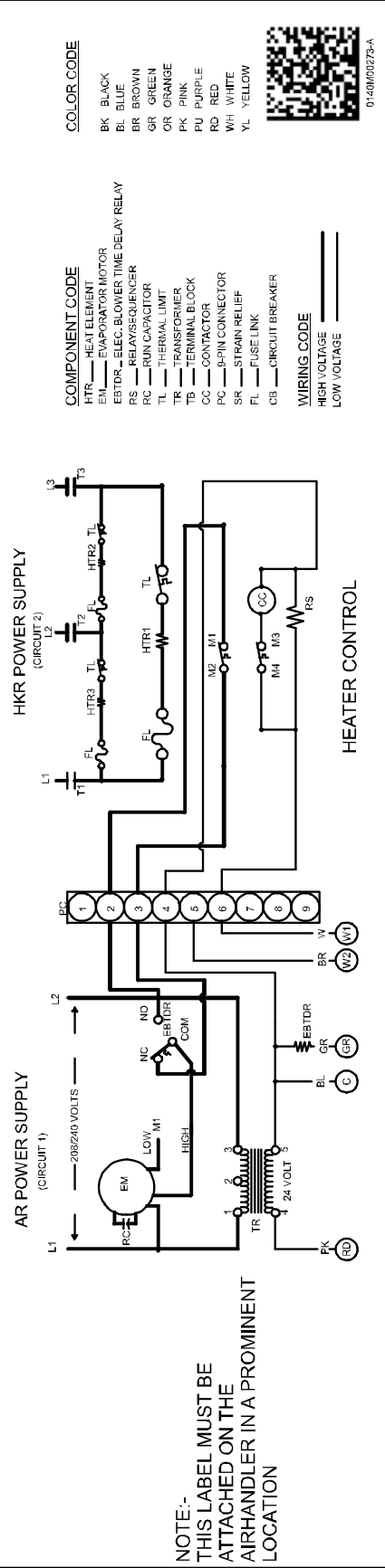

- COMPONENT CODE**
- HTR — HEAT ELEMENT
 - EM — EVAPORATOR MOTOR
 - EBTDR — ELEC. BLOWER TIME DELAY RELAY
 - RS — RELAYS/SEQUENCER
 - RC — RUN CAPACITOR
 - TL — THERMAL LIMIT
 - TR — TRANSFORMER
 - TB — TERMINAL BLOCK
 - CC — CONTACTOR
 - PC — 9-PIN CONNECTOR
 - SR — STRAIN RELIEF
 - FL — FUSE LINK
 - CB — CIRCUIT BREAKER
- WIRING CODE**
- HIGH VOLTAGE — _____
 - LOW VOLTAGE — _____
- COLOR CODE**
- BK — BLACK
 - BL — BLUE
 - BR — BROWN
 - GR — GREEN
 - OR — ORANGE
 - PK — PINK
 - PU — PURPLE
 - RD — RED
 - WH — WHITE
 - YL — YELLOW



NOTE:- THIS LABEL MUST BE ATTACHED ON THE AIRHANDLER IN A PROMINENT LOCATION

WIRING DIAGRAMS

WARNING

HIGH VOLTAGE!
DISCONNECT ALL POWER BEFORE SERVICING OR INSTALLING THIS UNIT. MULTIPLE POWER SOURCES MAY BE PRESENT. FAILURE TO DO SO MAY CAUSE PROPERTY DAMAGE, PERSONAL INJURY OR DEATH.

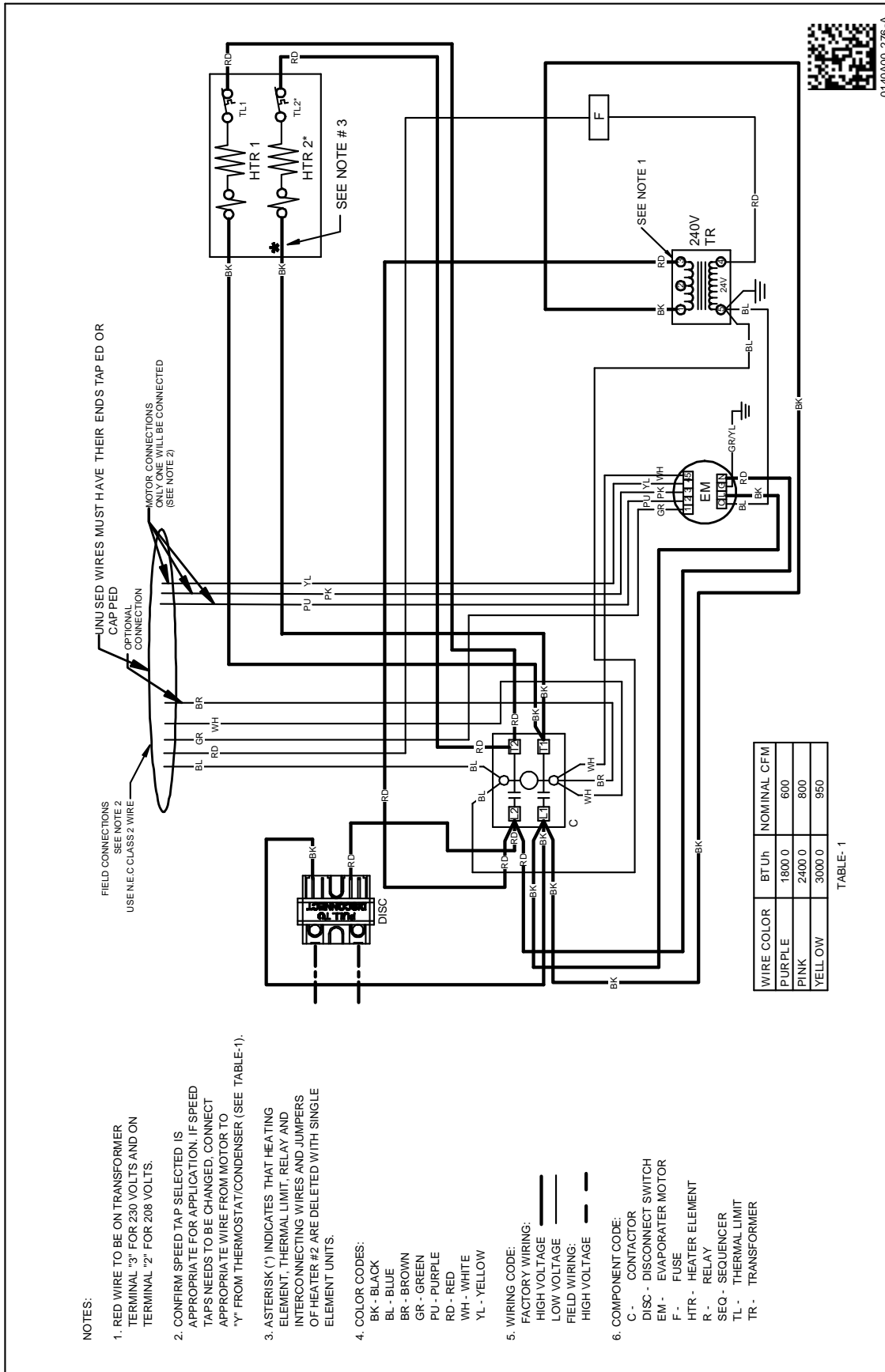

Wiring is subject to change. Always refer to the wiring diagram on the unit for the most up-to-date wiring.



HIGH VOLTAGE!
DISCONNECT ALL POWER BEFORE SERVICING OR INSTALLING THIS UNIT. MULTIPLE POWER SOURCES MAY BE PRESENT. FAILURE TO DO SO MAY CAUSE PROPERTY DAMAGE, PERSONAL INJURY OR DEATH.

WARNING

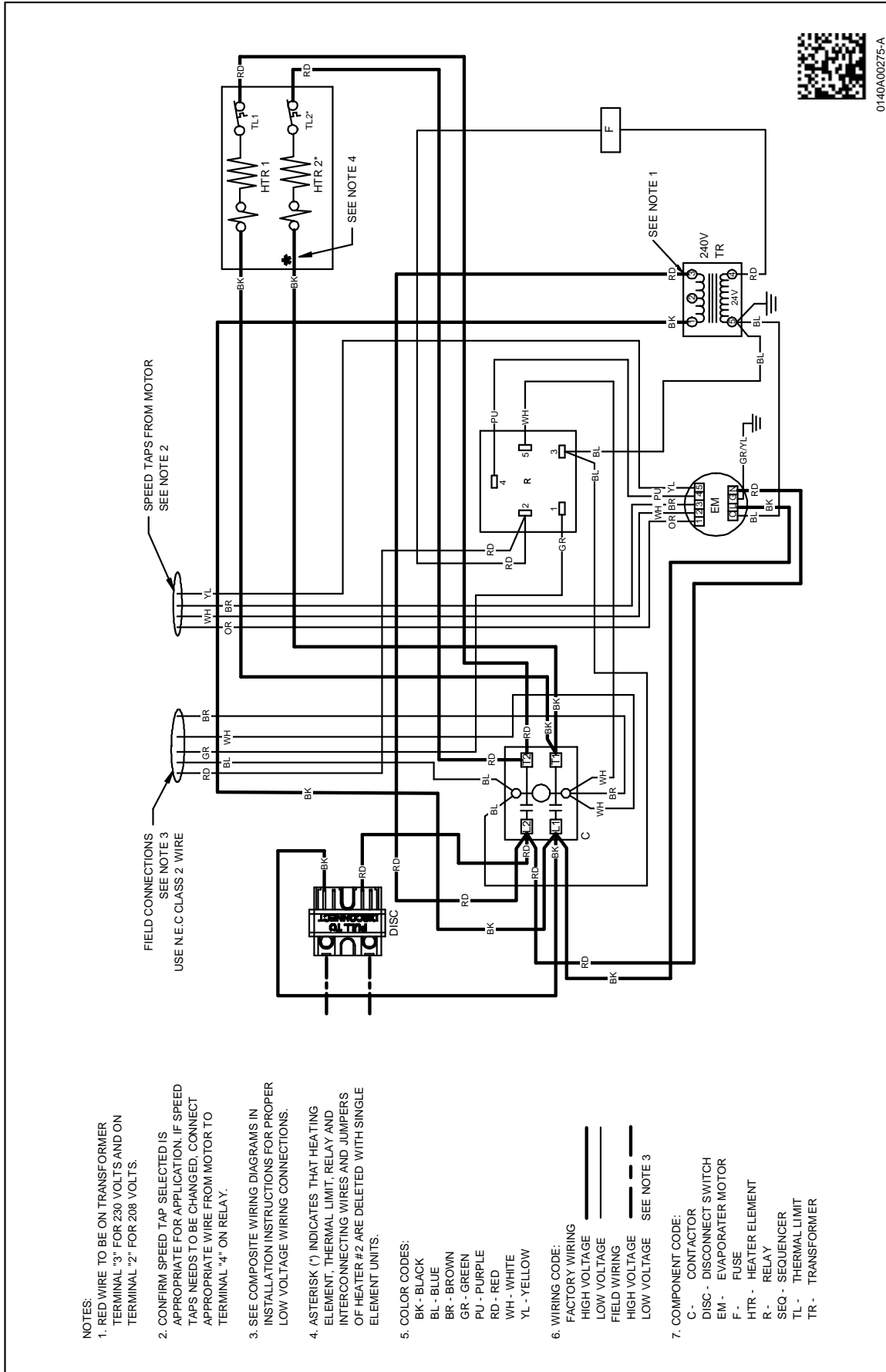

0140A00275-A

- NOTES:**
- RED WIRE TO BE ON TRANSFORMER TERMINAL "3" FOR 230 VOLTS AND ON TERMINAL "2" FOR 208 VOLTS.
 - CONFIRM SPEED TAP SELECTED IS APPROPRIATE FOR APPLICATION. IF SPEED TAPS NEEDS TO BE CHANGED, CONNECT APPROPRIATE WIRE FROM MOTOR TO TERMINAL "4" ON RELAY.
 - SEE COMPOSITE WIRING DIAGRAMS IN INSTALLATION INSTRUCTIONS FOR PROPER LOW VOLTAGE WIRING CONNECTIONS.
 - ASTERISK (*) INDICATES THAT HEATING ELEMENT, THERMAL LIMIT, RELAY AND INTERCONNECTING WIRES AND JUMPERS OF HEATER #2 ARE DELETED WITH SINGLE ELEMENT UNITS.
 - COLOR CODES:**
BK - BLACK
BL - BLUE
BR - BROWN
GR - GREEN
PU - PURPLE
RD - RED
WH - WHITE
YL - YELLOW
 - WIRING CODE:**
FACTORY WIRING
HIGH VOLTAGE
LOW VOLTAGE
FIELD WIRING
HIGH VOLTAGE
LOW VOLTAGE
SEE NOTE 3
 - COMPONENT CODE:**
C - CONTACTOR
DISC - DISCONNECT SWITCH
EM - EVAPORATOR MOTOR
F - FUSE
HTR - HEATER ELEMENT
R - RELAY
SEQ - SEQUENCER
TL - THERMAL LIMIT
TR - TRANSFORMER

Wiring is subject to change. Always refer to the wiring diagram on the unit for the most up-to-date wiring.

WARNING
 HIGH VOLTAGE!
 DISCONNECT ALL POWER BEFORE SERVICING OR INSTALLING THIS UNIT. MULTIPLE POWER SOURCES MAY BE PRESENT. FAILURE TO DO SO MAY CAUSE PROPERTY DAMAGE, PERSONAL INJURY OR DEATH.

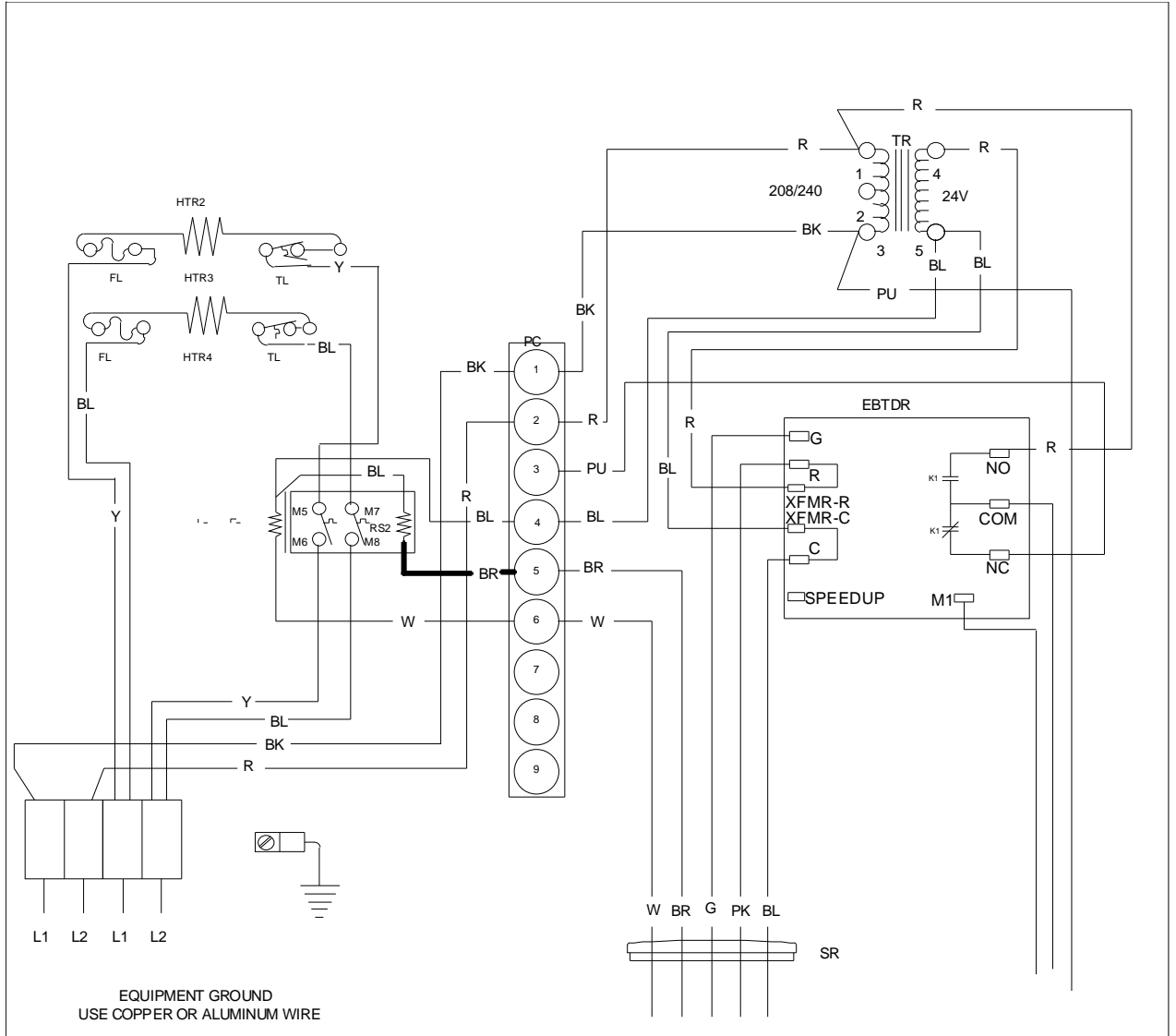

USE COPPER WIRE

Typical Wiring Schematic MBR Blower with Electric Heat.
 This wiring diagram is for reference only. Not all wiring is as shown above.
 Refer to the appropriate wiring diagram for the unit being serviced.

Wiring is subject to change. Always refer to the wiring diagram on the unit for the most up-to-date wiring.



HIGH VOLTAGE!
 DISCONNECT ALL POWER BEFORE SERVICING OR INSTALLING THIS UNIT. MULTIPLE POWER SOURCES MAY BE PRESENT. FAILURE TO DO SO MAY CAUSE PROPERTY DAMAGE, PERSONAL INJURY OR DEATH.

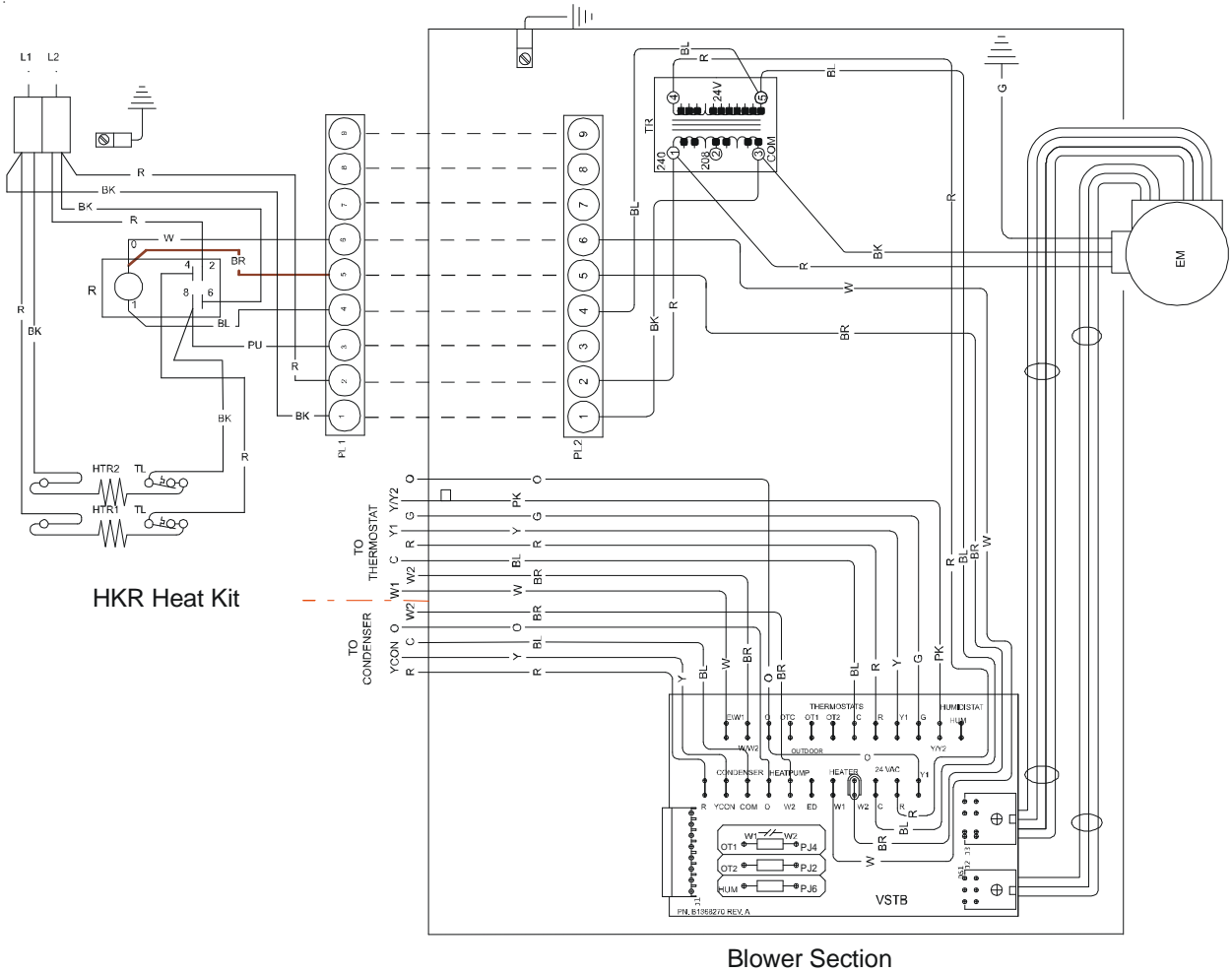

Typical Wiring Schematic MBE Blower with Electric Heat.
 This wiring diagram is for reference only.
 Not all wiring is as shown above.

Wiring is subject to change. Always refer to the wiring diagram on the unit for the most up-to-date wiring.

WIRING DIAGRAMS

WARNING
HIGH VOLTAGE!
DISCONNECT ALL POWER BEFORE SERVICING OR INSTALLING THIS UNIT. MULTIPLE POWER SOURCES MAY BE PRESENT. FAILURE TO DO SO MAY CAUSE PROPERTY DAMAGE, PERSONAL INJURY OR DEATH.

REMOTE - SPLITS A/C



WARNING
HIGH VOLTAGE!
 DISCONNECT ALL POWER BEFORE SERVICING OR INSTALLING THIS UNIT. MULTIPLE POWER SOURCES MAY BE PRESENT. FAILURE TO DO SO MAY CAUSE PROPERTY DAMAGE, PERSONAL INJURY OR DEATH.

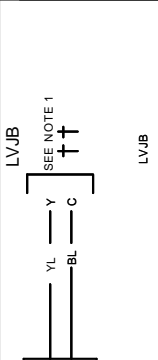
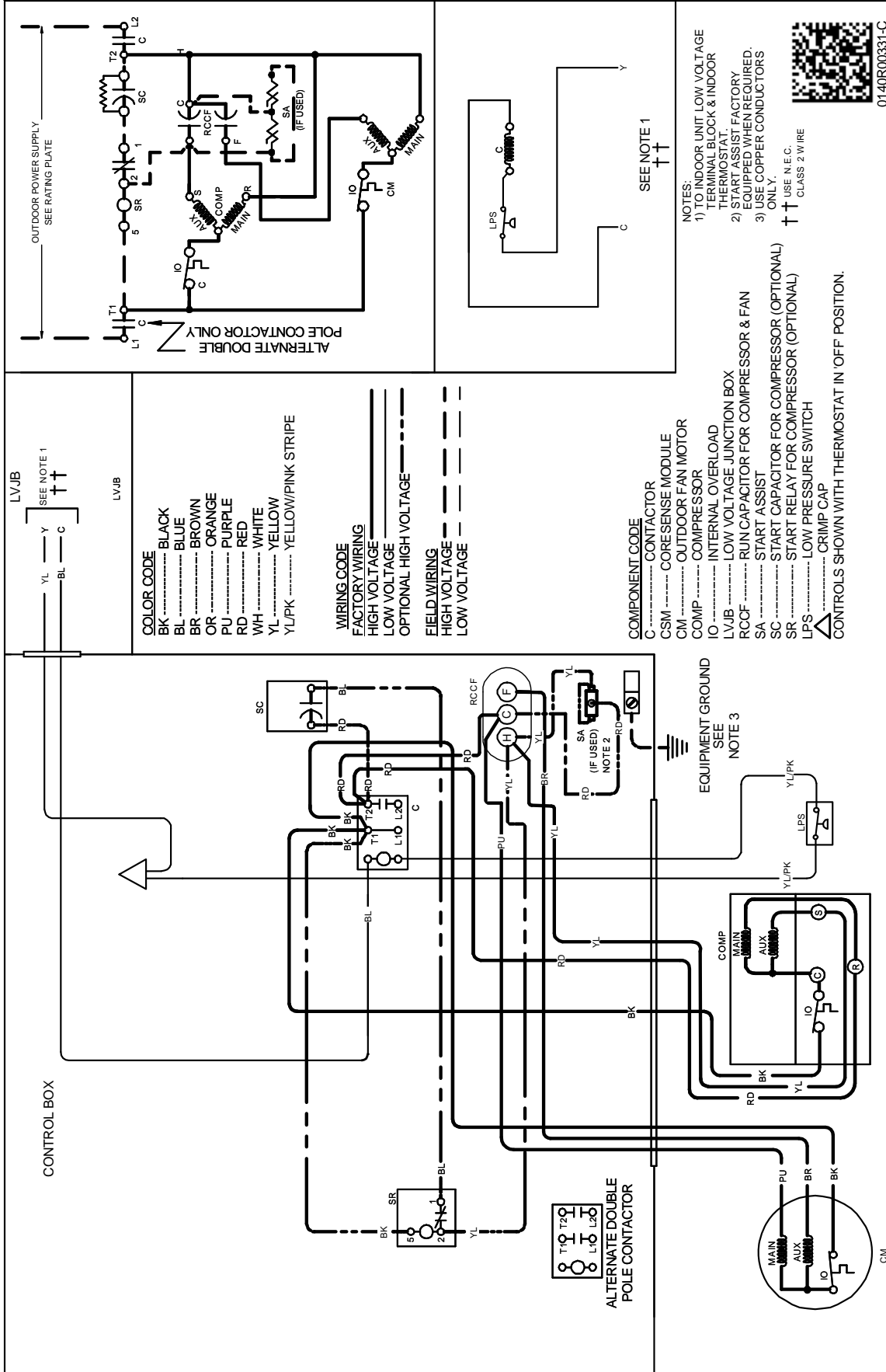

- COLOR CODE**
- BK BLACK
 - BL BLUE
 - BR BROWN
 - OR ORANGE
 - PU PURPLE
 - RD RED
 - WH WHITE
 - YL YELLOW
 - YL/PK YELLOW/PINK STRIPE

- WIRING CODE**
- FACTORY WIRING
 - HIGH VOLTAGE
 - LOW VOLTAGE
 - OPTIONAL HIGH VOLTAGE
 - FIELD WIRING
 - HIGH VOLTAGE
 - LOW VOLTAGE

- COMPONENT CODE**
- C CONTACTOR
 - CSM CORESENSE MODULE
 - CM OUTDOOR FAN MOTOR
 - COMP COMPRESSOR
 - IO INTERNAL OVERLOAD
 - LVJB LOW VOLTAGE JUNCTION BOX
 - RCCF RUN CAPACITOR FOR COMPRESSOR & FAN
 - SA START ASSIST
 - SC START CAPACITOR FOR COMPRESSOR (OPTIONAL)
 - SR START RELAY FOR COMPRESSOR (OPTIONAL)
 - LPS LOW PRESSURE SWITCH
 - CRIMP CAP CRIMP CAP
- CONTROLS SHOWN WITH THERMOSTAT IN OFF POSITION.

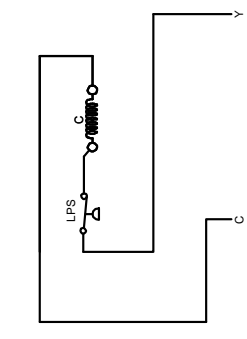
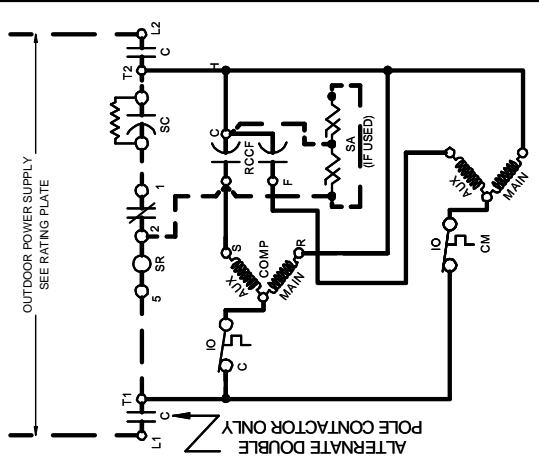

SEE NOTE 1

- NOTES:**
- 1) TO INDOOR UNIT, LOW VOLTAGE TERMINAL BLOCK & INDOOR THERMOSTAT.
 - 2) START ASSIST FACTORY EQUIPPED WHEN REQUIRED.
 - 3) USE COPPER CONDUCTORS ONLY.
- ↑↑ USE N.E.C. CLASS 2 WIRE



0140R00331-C

Wiring is subject to change. Always refer to the wiring diagram on the unit for the most up-to-date wiring.

WIRING DIAGRAMS

ANX130[30-61]1A*
ANX140[18-60]1A*



WARNING
HIGH VOLTAGE!
DISCONNECT ALL POWER BEFORE SERVICING OR INSTALLING THIS UNIT. MULTIPLE POWER SOURCES MAY BE PRESENT. FAILURE TO DO SO MAY CAUSE PROPERTY DAMAGE, PERSONAL INJURY OR DEATH.

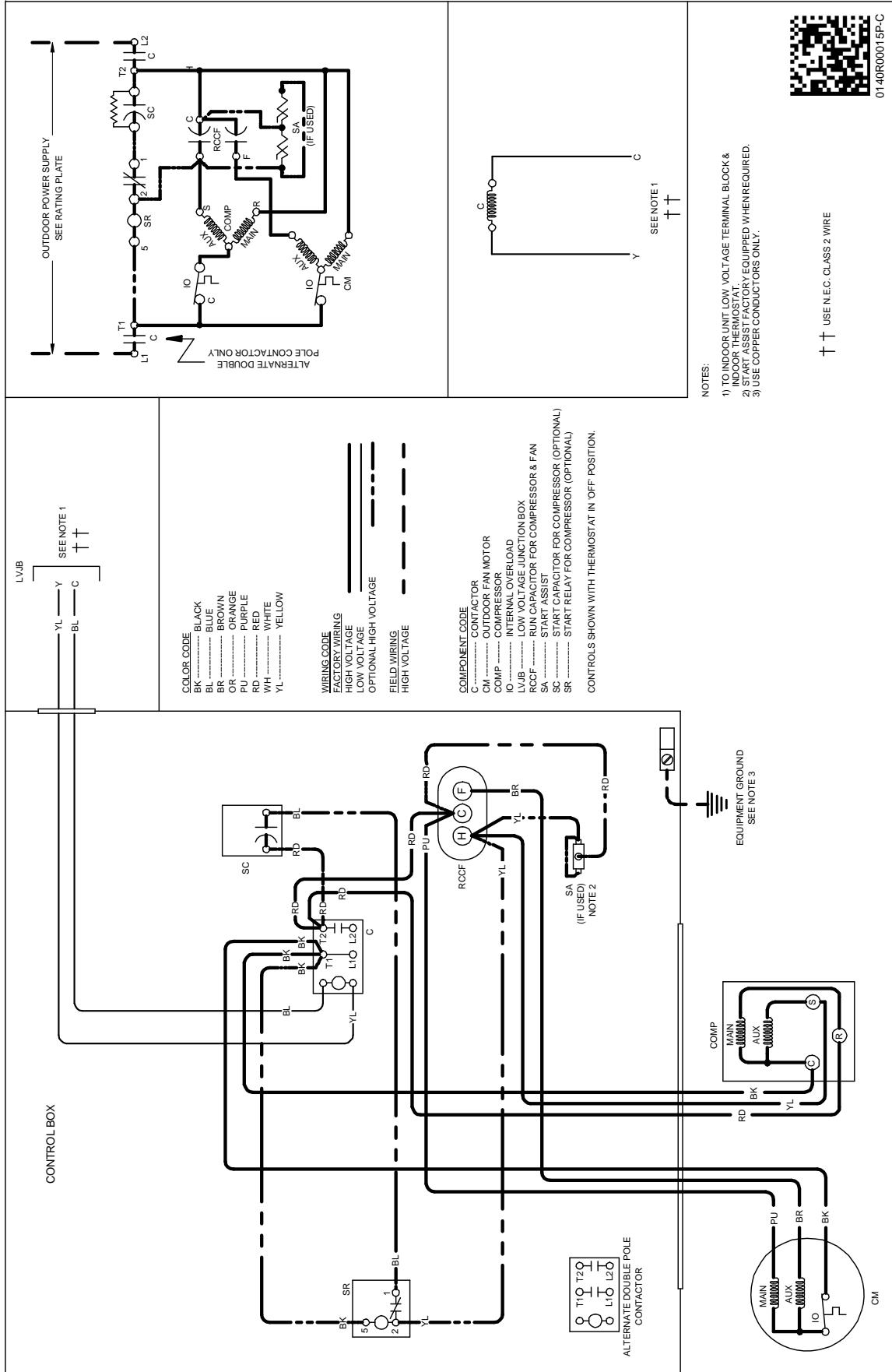

01-40R00019P-C

Wiring is subject to change. Always refer to the wiring diagram on the unit for the most up-to-date wiring.



WARNING
 HIGH VOLTAGE!
 DISCONNECT ALL POWER BEFORE SERVICING OR INSTALLING THIS UNIT. MULTIPLE POWER SOURCES MAY BE PRESENT. FAILURE TO DO SO MAY CAUSE PROPERTY DAMAGE, PERSONAL INJURY OR DEATH.

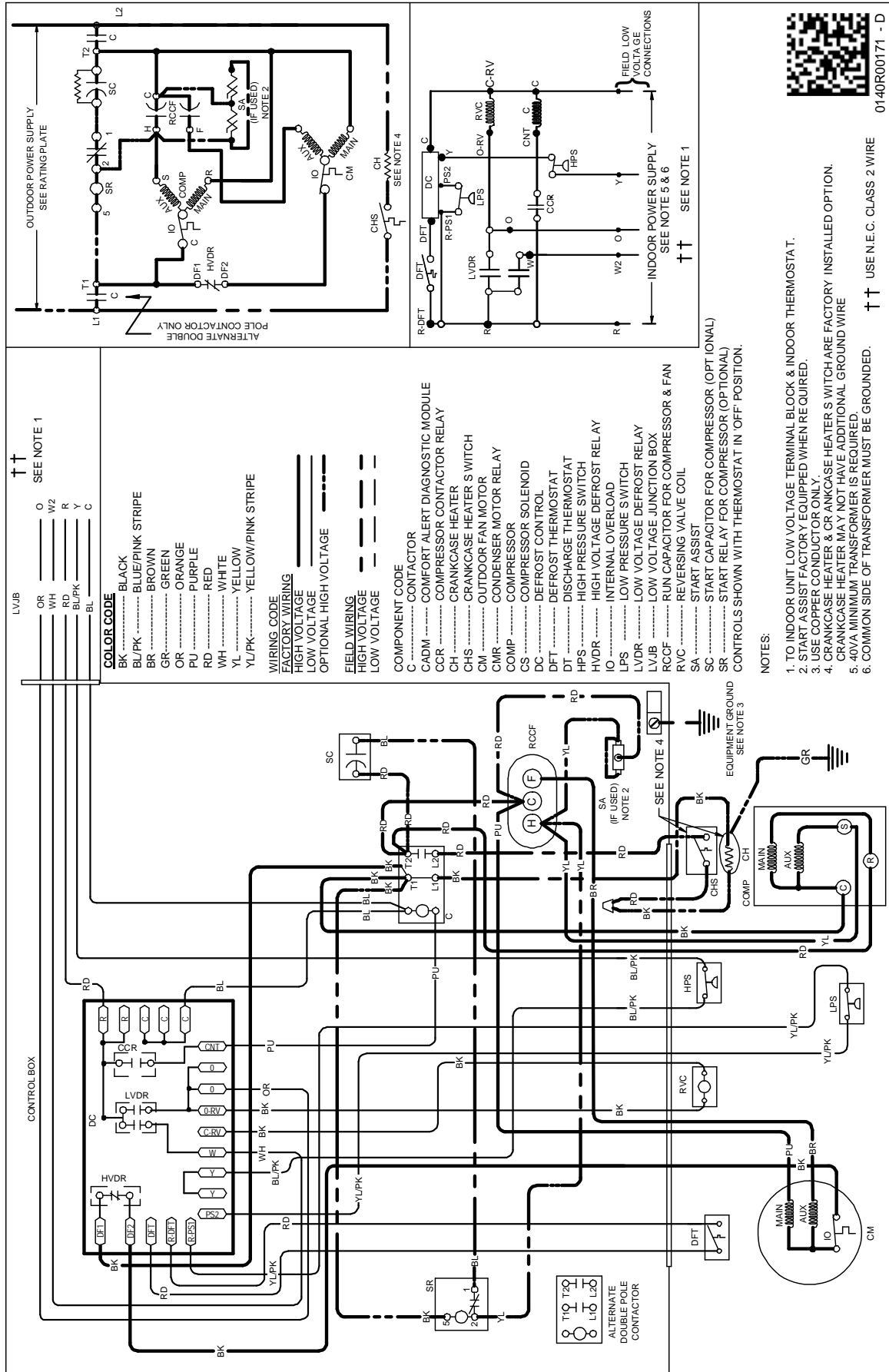

Wiring is subject to change. Always refer to the wiring diagram on the unit for the most up-to-date wiring.



0140R00171 - D

USE N.E.C. CLASS 2 WIRE

ASX130181D* / ASX130[24, 30, 48]1CC-CE ASX130361[CC,CD]/D*

WIRING DIAGRAMS



WARNING
HIGH VOLTAGE!
DISCONNECT ALL POWER BEFORE SERVICING OR INSTALLING THIS UNIT. MULTIPLE POWER SOURCES MAY BE PRESENT. FAILURE TO DO SO MAY CAUSE PROPERTY DAMAGE, PERSONAL INJURY OR DEATH.

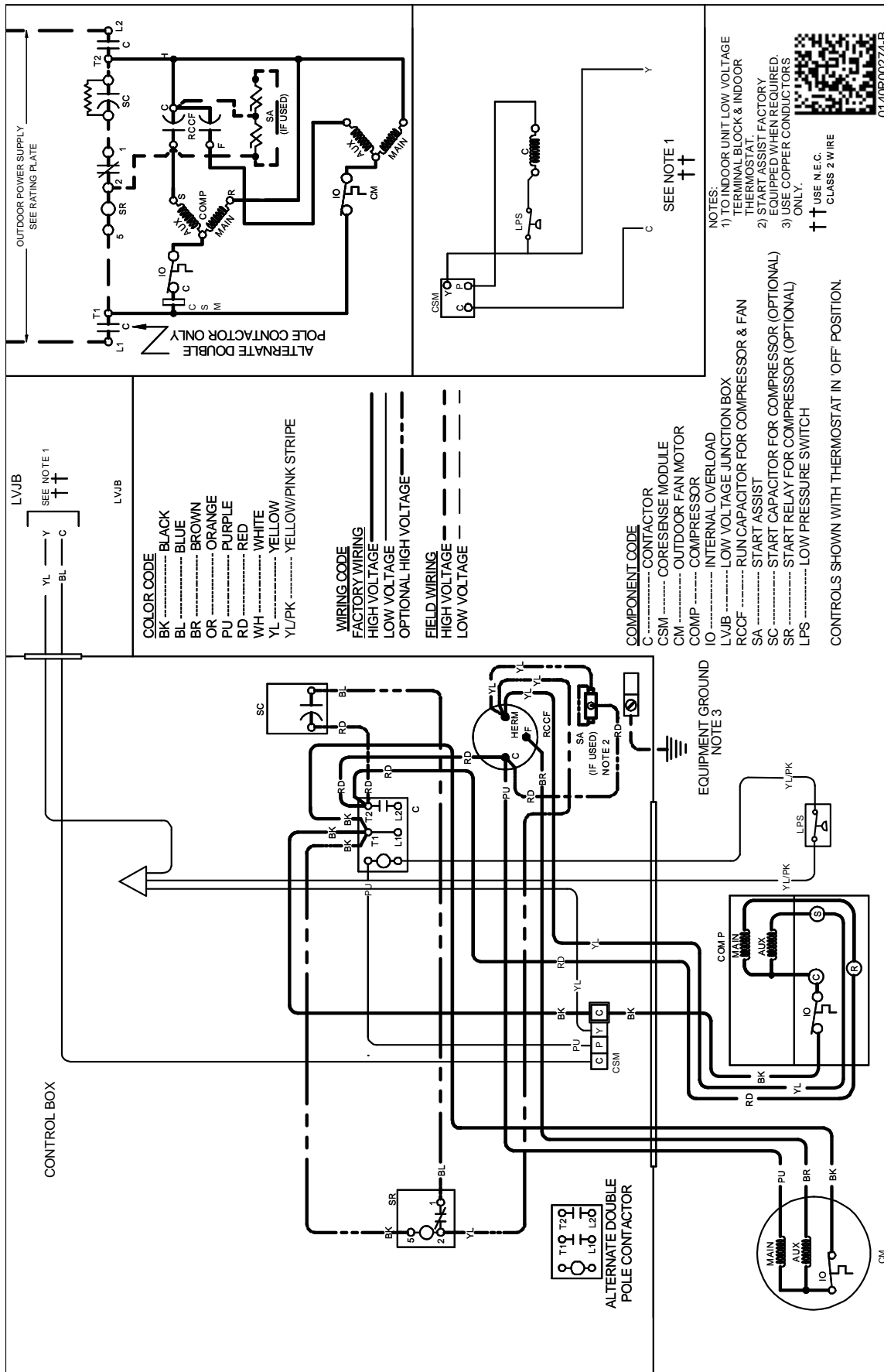

Wiring is subject to change. Always refer to the wiring diagram on the unit for the most up-to-date wiring.

WIRING DIAGRAMS

ASX140[18-36/48]1C[A/B] ASX140421D[A/B] / ASX140[48-60]1[BA/B]



WARNING
HIGH VOLTAGE!
DISCONNECT ALL POWER BEFORE SERVICING OR INSTALLING THIS UNIT. MULTIPLE POWER SOURCES MAY BE PRESENT. FAILURE TO DO SO MAY CAUSE PROPERTY DAMAGE, PERSONAL INJURY OR DEATH.

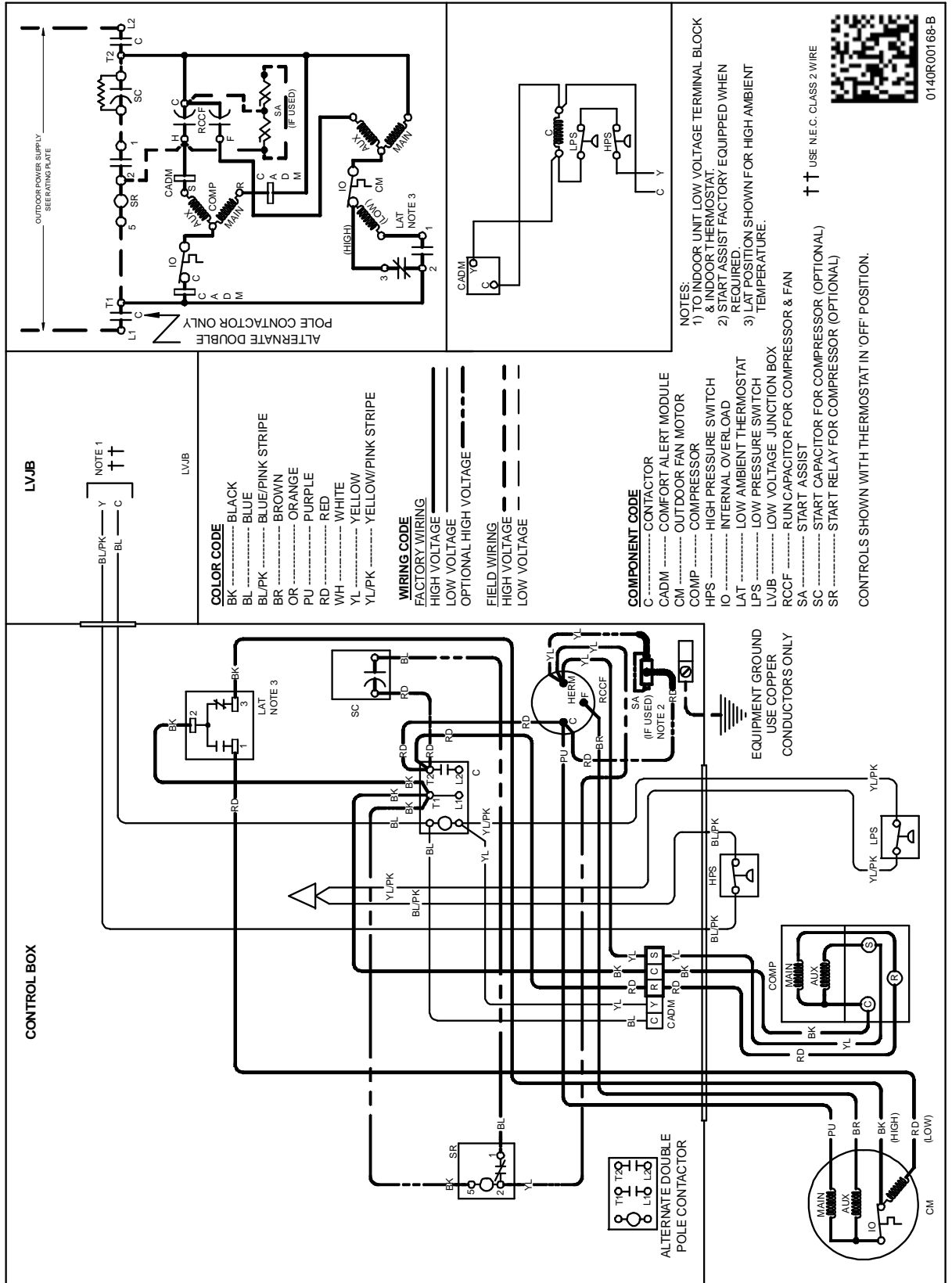

Wiring is subject to change. Always refer to the wiring diagram on the unit for the most up-to-date wiring.

WIRING DIAGRAMS



WARNING
HIGH VOLTAGE!
DISCONNECT ALL POWER BEFORE SERVICING OR INSTALLING THIS UNIT. MULTIPLE POWER SOURCES MAY BE PRESENT. FAILURE TO DO SO MAY CAUSE PROPERTY DAMAGE, PERSONAL INJURY OR DEATH.

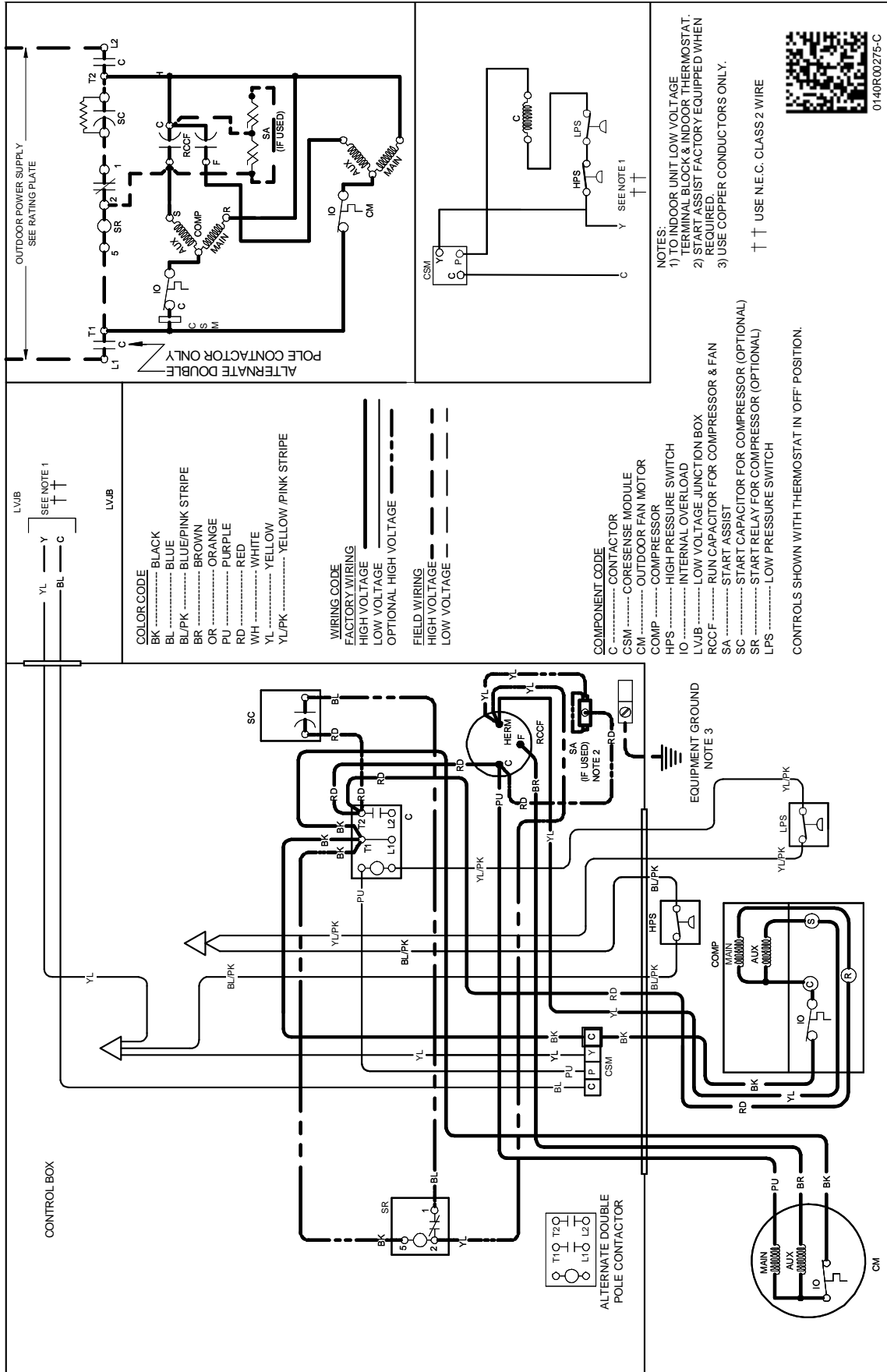

Wiring is subject to change. Always refer to the wiring diagram on the unit for the most up-to-date wiring.



WARNING
 HIGH VOLTAGE!
 DISCONNECT ALL POWER BEFORE SERVICING OR INSTALLING THIS UNIT. MULTIPLE POWER SOURCES MAY BE PRESENT. FAILURE TO DO SO MAY CAUSE PROPERTY DAMAGE, PERSONAL INJURY OR DEATH.

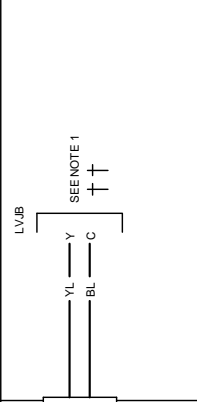
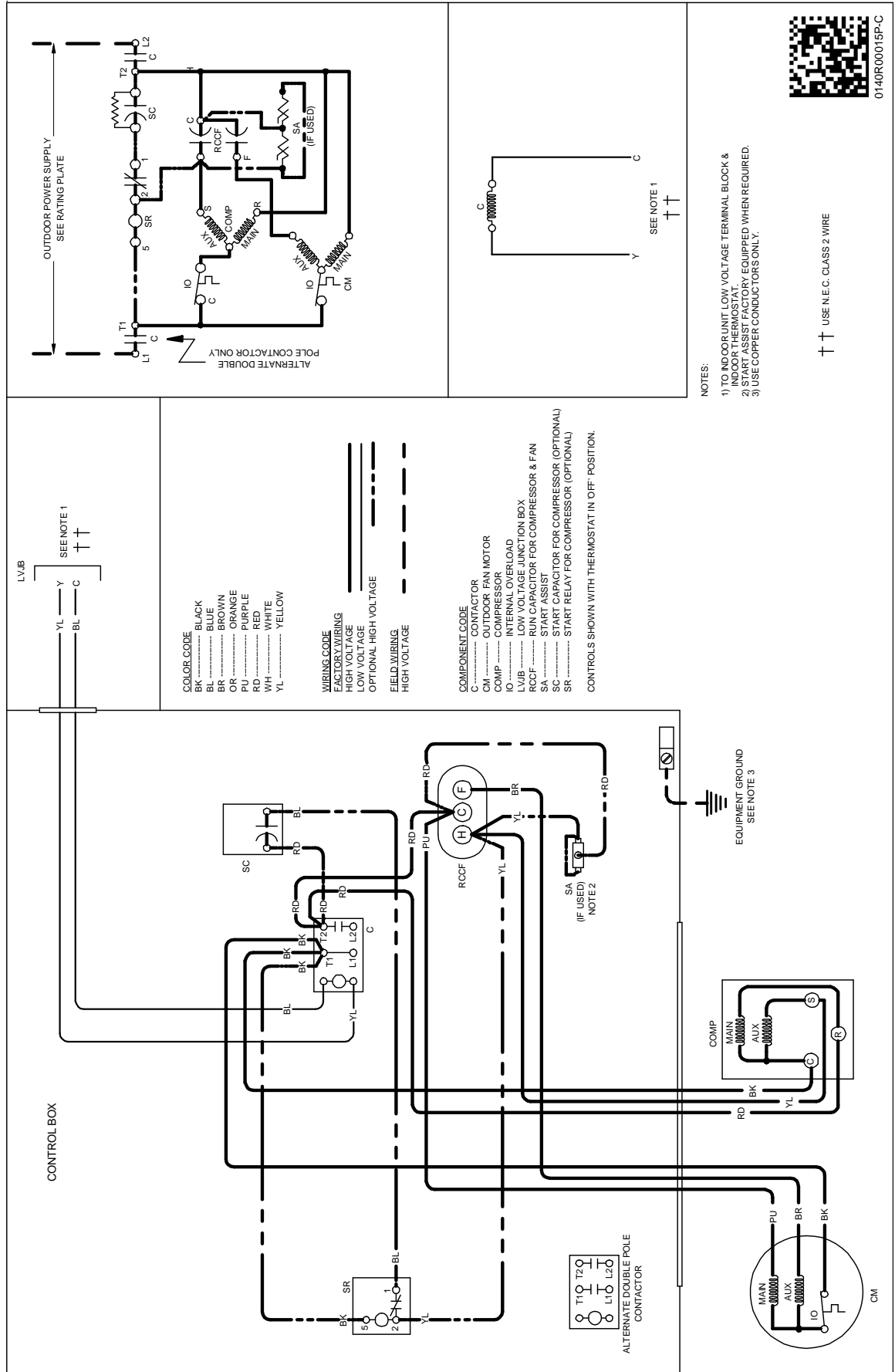

- COLOR CODE**
 BK BLACK
 BL BLUE
 BR BROWN
 OR ORANGE
 PU PURPLE
 RD RED
 WH WHITE
 YL YELLOW

- WIRING CODE**
 FACTORY WIRING
 HIGH VOLTAGE
 LOW VOLTAGE
 OPTIONAL HIGH VOLTAGE
 FIELD WIRING
 HIGH VOLTAGE

- COMPONENT CODE**
 C CONTACTOR
 CM OUTDOOR FAN MOTOR
 COMP COMPRESSOR
 IO INTERNAL OVERLOAD
 LVJB LOW VOLTAGE JUNCTION BOX
 RCCF RUN CAPACITOR FOR COMPRESSOR & FAN
 SA START CAPACITOR FOR COMPRESSOR (OPTIONAL)
 SR START RELAY FOR COMPRESSOR (OPTIONAL)
- CONTROLS SHOWN WITH THERMOSTAT IN OFF POSITION.

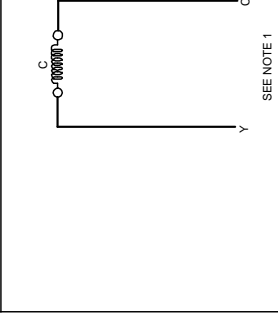

- NOTES:**
 1) TO INDOOR UNIT LOW VOLTAGE TERMINAL BLOCK & INDOOR THERMOSTAT
 2) START ASSIST FACTORY EQUIPPED WHEN REQUIRED.
 3) USE COPPER CONDUCTORS ONLY.



0140R00015P-C

↑↑ USE N.E.C. CLASS 2 WIRE

Wiring is subject to change. Always refer to the wiring diagram on the unit for the most up-to-date wiring.



WARNING
HIGH VOLTAGE!
 DISCONNECT ALL POWER BEFORE SERVICING OR INSTALLING THIS UNIT. MULTIPLE POWER SOURCES MAY BE PRESENT. FAILURE TO DO SO MAY CAUSE PROPERTY DAMAGE, PERSONAL INJURY OR DEATH.

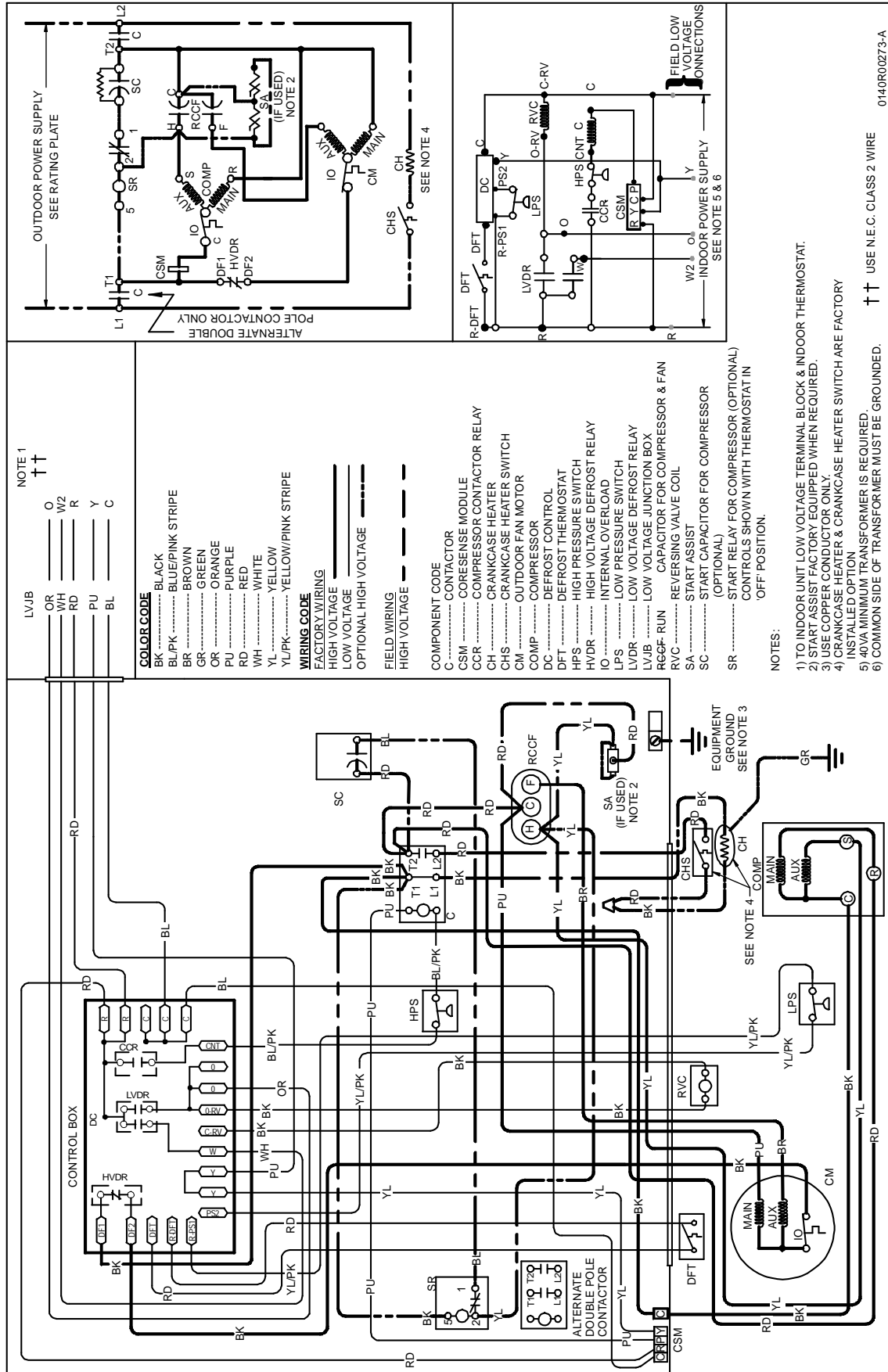

NOTE 1
 ††

LVJB	OR	O
	WH	W2
	RD	R
	PU	Y
	BL	C

COLOR CODE
 BK BLACK
 BL/PK BLUE/PINK STRIPE
 BR BROWN
 GR GREEN
 OR ORANGE
 PU PURPLE
 RD RED
 WH WHITE
 YL YELLOW
 YL/PK YELLOW/PINK STRIPE

WIRING CODE
 FACTORY WIRING
 HIGH VOLTAGE
 LOW VOLTAGE
 OPTIONAL HIGH VOLTAGE
 FIELD WIRING
 HIGH VOLTAGE

COMPONENT CODE
 C CONTACTOR
 CSM CORESENSE MODULE
 DC COMPRESSOR CONTACTOR RELAY
 DFT CRANKCASE HEATER
 CHS CRANKCASE HEATER SWITCH
 CM OUTDOOR FAN MOTOR
 COMP COMPRESSOR
 DFT DEFROST CONTROL
 DFT DEFROST THERMOSTAT
 HPS HIGH PRESSURE SWITCH
 HVDR HIGH VOLTAGE DEFROST RELAY
 IO INTERNAL OVERLOAD
 LPS LOW PRESSURE SWITCH
 LVDR LOW VOLTAGE DEFROST RELAY
 LVJB LOW VOLTAGE DEFROST RELAY
 RGGF RUN CAPACITOR FOR COMPRESSOR & FAN
 RVC REVERSING VALVE COIL
 SA START ASSIST (OPTIONAL)
 SC START CAPACITOR FOR COMPRESSOR (OPTIONAL)
 SR START RELAY FOR COMPRESSOR (OPTIONAL)
 CONTROLS SHOWN WITH THERMOSTAT IN 'OFF' POSITION.

NOTES:

- 1) TO INDOOR UNIT LOW VOLTAGE TERMINAL BLOCK & INDOOR THERMOSTAT.
- 2) START ASSIST FACTORY EQUIPPED WHEN REQUIRED.
- 3) USE COPPER CONDUCTOR ONLY.
- 4) CRANKCASE HEATER & CRANKCASE HEATER SWITCH ARE FACTORY INSTALLED OPTION.
- 5) 40VA MINIMUM TRANSFORMER IS REQUIRED.
- 6) COMMON SIDE OF TRANSFORMER MUST BE GROUNDED.

0140R00273-A

Wiring is subject to change. Always refer to the wiring diagram on the unit for the most up-to-date wiring.

WIRING DIAGRAMS



WARNING
 HIGH VOLTAGE!
 DISCONNECT ALL POWER BEFORE SERVICING OR INSTALLING THIS UNIT. MULTIPLE POWER SOURCES MAY BE PRESENT. FAILURE TO DO SO MAY CAUSE PROPERTY DAMAGE, PERSONAL INJURY OR DEATH.

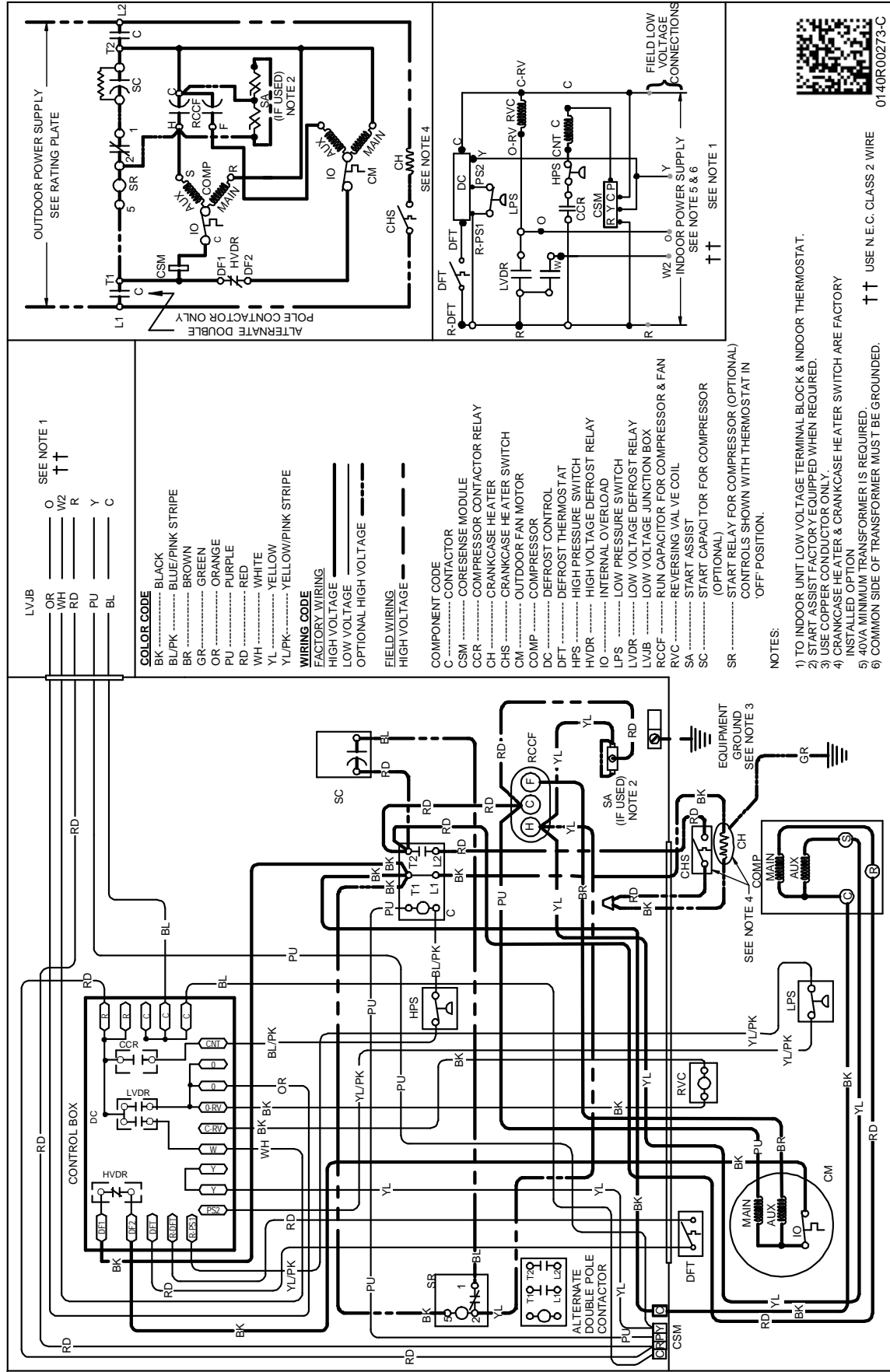

LVJB	O	SEE NOTE 1
OR	W2	↑↑
WH	R	
RD	Y	
PU	C	
BL		

- COLOR CODE**
 BK BLACK
 BL/PK BLUE/PINK STRIPE
 BR BROWN
 GR GREEN
 OR ORANGE
 PU PURPLE
 RD RED
 WH WHITE
 YL YELLOW
 YL/PK YELLOW/PINK STRIPE
- WIRING CODE**
 FACTORY WIRING
 HIGH VOLTAGE
 LOW VOLTAGE
 OPTIONAL HIGH VOLTAGE
 FIELD WIRING
 HIGH VOLTAGE
 LOW VOLTAGE
- COMPONENT CODE**
 C CONTACTOR
 CSM CORESENE MODULE
 CCR COMPRESSOR CONTACTOR RELAY
 CH CRANKCASE HEATER
 CHS CRANKCASE HEATER SWITCH
 CM OUTDOOR FAN MOTOR
 COMP COMPRESSOR
 DC DEFROST CONTROL
 DFT DEFROST THERMOSTAT
 HPS HIGH PRESSURE SWITCH
 HVDR HIGH VOLTAGE DEFROST RELAY
 IO INTERNAL OVERLOAD
 LPS LOW PRESSURE SWITCH
 LVDR LOW VOLTAGE DEFROST RELAY
 LVJB LOW VOLTAGE JUNCTION BOX
 RVC REVERSING VALVE COIL
 SA START ASSIST
 SC START CAPACITOR FOR COMPRESSOR (OPTIONAL)
 SR START RELAY FOR COMPRESSOR (OPTIONAL)
 CONTROLS SHOWN WITH THERMOSTAT IN 'OFF' POSITION.

- NOTES:**
- 1) TO INDOOR UNIT LOW VOLTAGE TERMINAL BLOCK & INDOOR THERMOSTAT.
 - 2) START ASSIST FACTORY EQUIPPED WHEN REQUIRED.
 - 3) USE COPPER CONDUCTOR ONLY.
 - 4) CRANKCASE HEATER & CRANKCASE HEATER SWITCH ARE FACTORY INSTALLED OPTION.
 - 5) 40VA MINIMUM TRANSFORMER IS REQUIRED.
 - 6) COMMON SIDE OF TRANSFORMER MUST BE GROUNDED.
- ↑↑ USE N.E.C. CLASS 2 WIRE



0140R00273-C

Wiring is subject to change. Always refer to the wiring diagram on the unit for the most up-to-date wiring.



WARNING
 HIGH VOLTAGE!
 DISCONNECT ALL POWER BEFORE SERVICING OR INSTALLING THIS UNIT. MULTIPLE POWER SOURCES MAY BE PRESENT. FAILURE TO DO SO MAY CAUSE PROPERTY DAMAGE, PERSONAL INJURY OR DEATH.

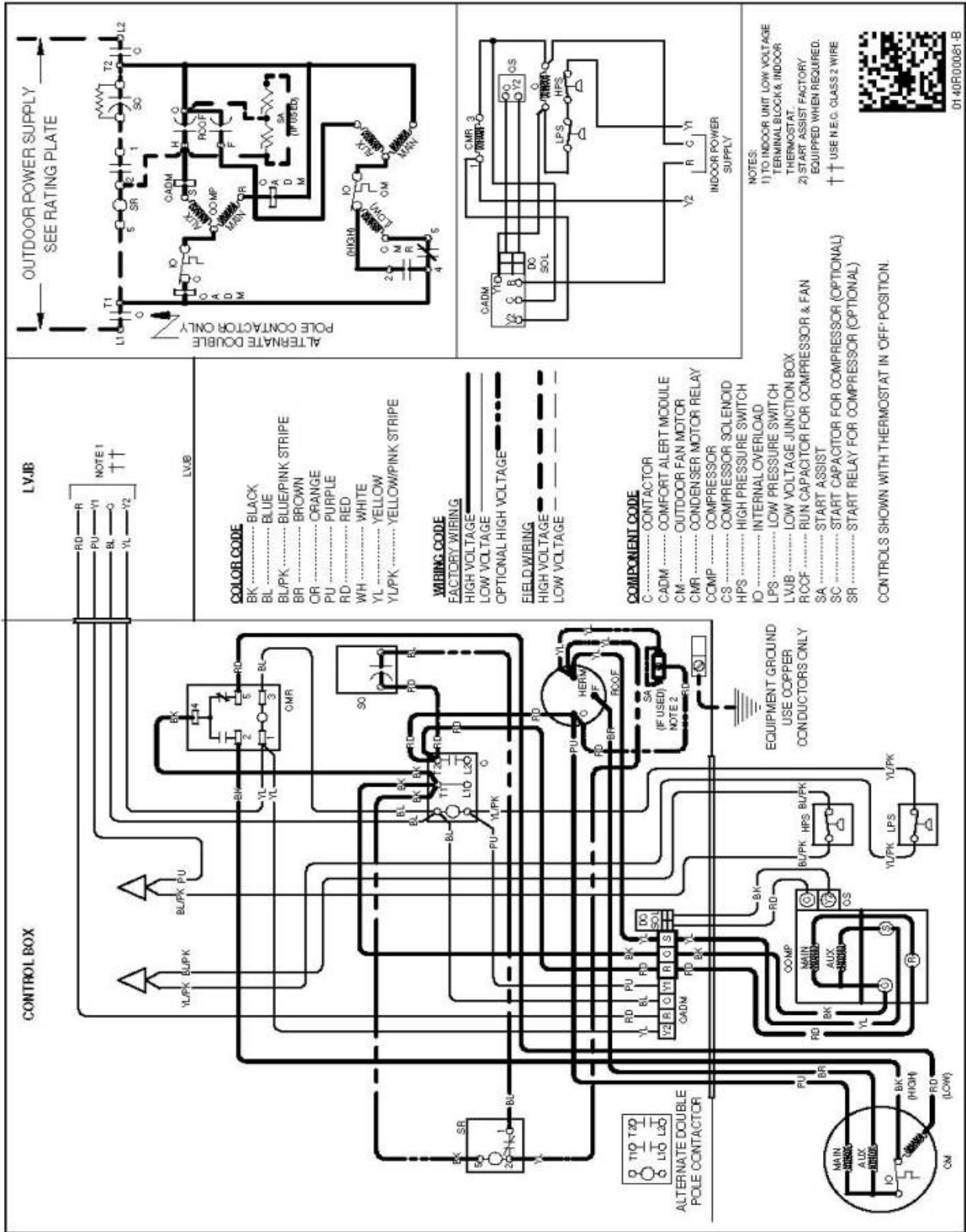

Wiring is subject to change. Always refer to the wiring diagram on the unit for the most up-to-date wiring.



WARNING
 HIGH VOLTAGE!
 DISCONNECT ALL POWER BEFORE SERVICING OR INSTALLING THIS UNIT. MULTIPLE POWER SOURCES MAY BE PRESENT. FAILURE TO DO SO MAY CAUSE PROPERTY DAMAGE, PERSONAL INJURY OR DEATH.

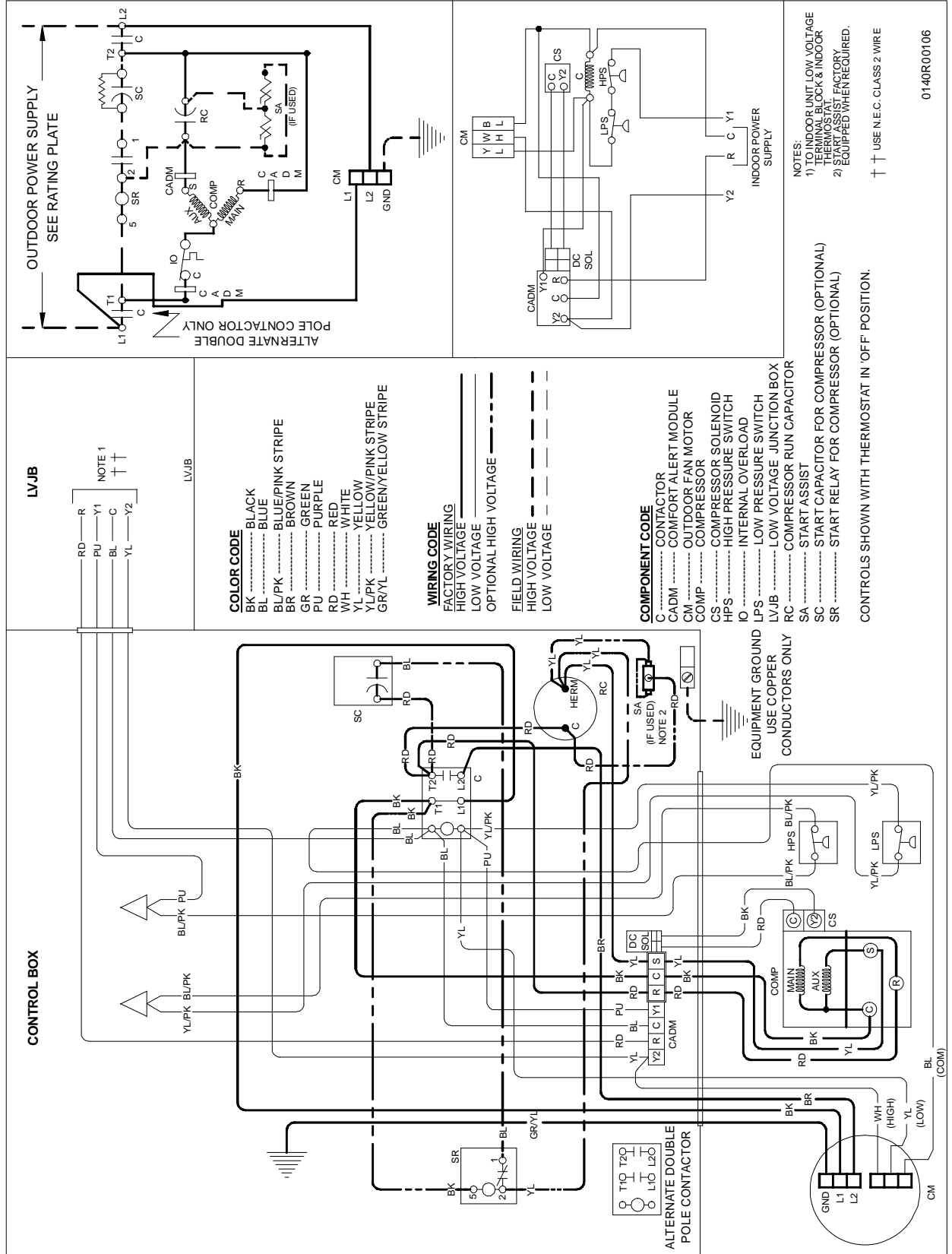

0140R00106

Wiring is subject to change. Always refer to the wiring diagram on the unit for the most up-to-date wiring.



WARNING
 HIGH VOLTAGE!
 DISCONNECT ALL POWER BEFORE SERVICING OR INSTALLING THIS UNIT. MULTIPLE POWER SOURCES MAY BE PRESENT. FAILURE TO DO SO MAY CAUSE PROPERTY DAMAGE, PERSONAL INJURY OR DEATH.

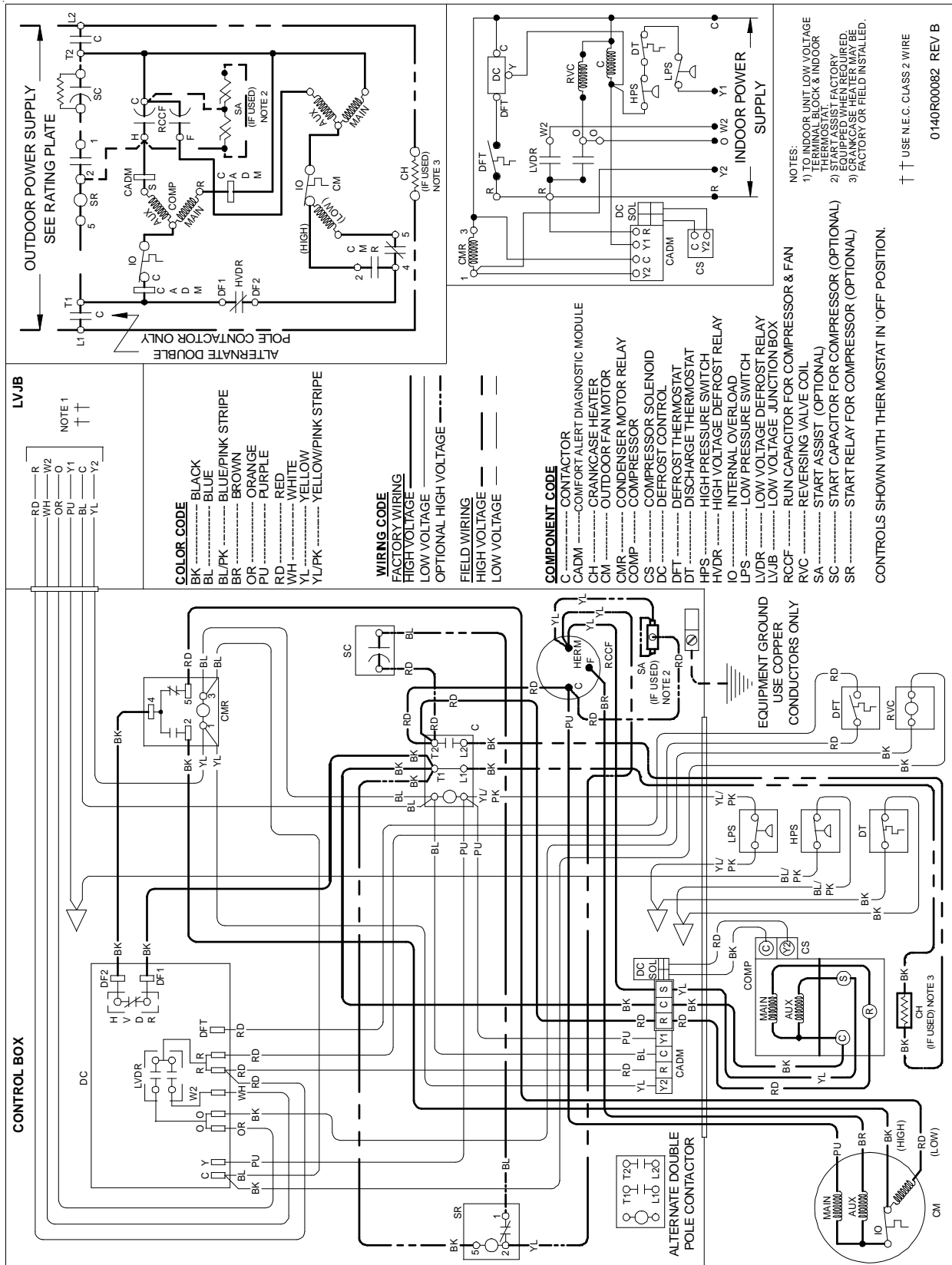

Wiring is subject to change. Always refer to the wiring diagram on the unit for the most up-to-date wiring.

WARNING
HIGH VOLTAGE!
 DISCONNECT ALL POWER BEFORE SERVICING OR INSTALLING THIS UNIT. MULTIPLE POWER SOURCES MAY BE PRESENT. FAILURE TO DO SO MAY CAUSE PROPERTY DAMAGE, PERSONAL INJURY OR DEATH.

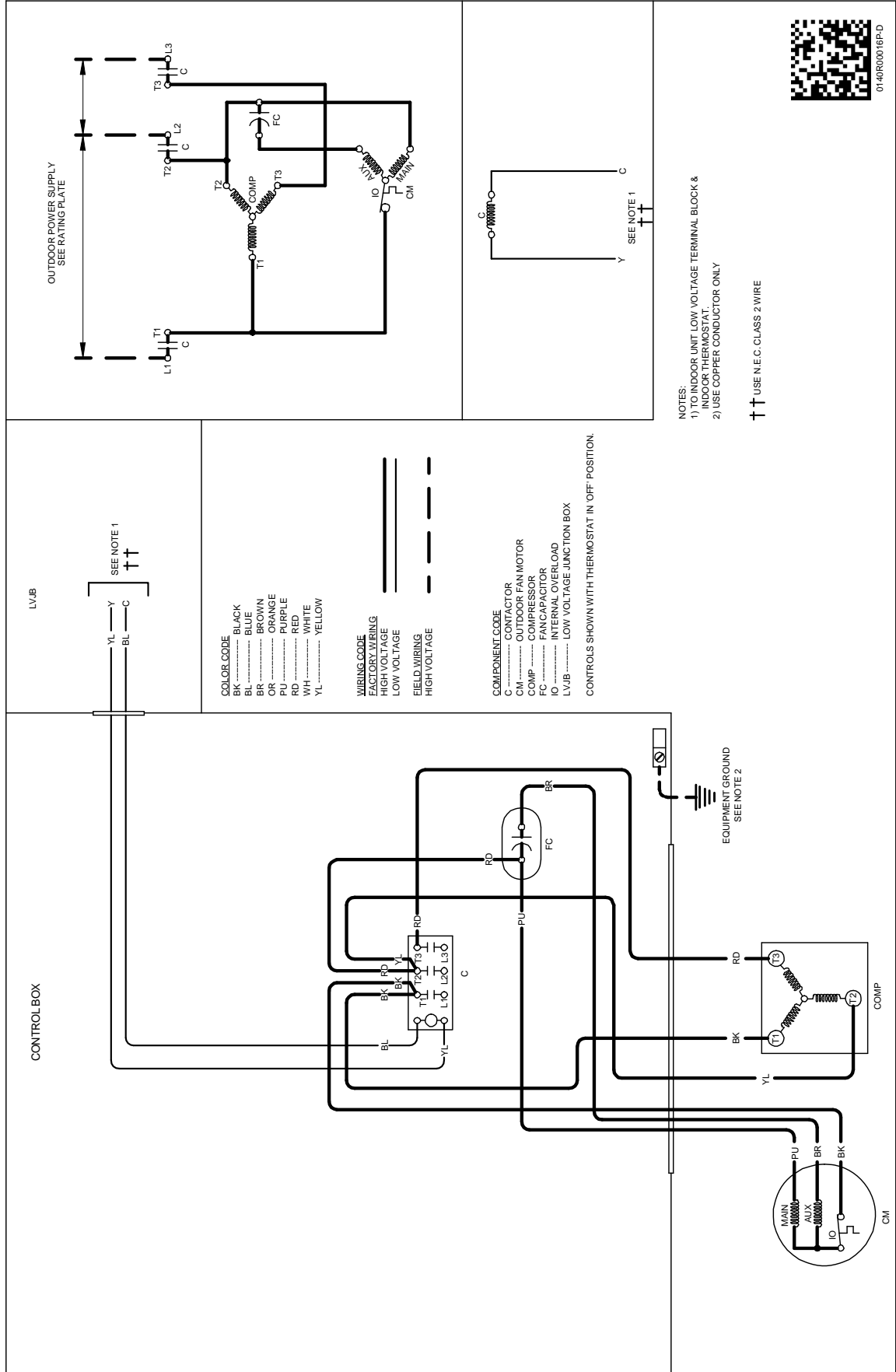

01-40R00016PFD

Wiring is subject to change. Always refer to the wiring diagram on the unit for the most up-to-date wiring.

WIRING DIAGRAMS

GSX140[18-60]1K*, GSX160[18-48, 611]1F*



WARNING
HIGH VOLTAGE!
DISCONNECT ALL POWER BEFORE SERVICING OR INSTALLING THIS UNIT. MULTIPLE POWER SOURCES MAY BE PRESENT. FAILURE TO DO SO MAY CAUSE PROPERTY DAMAGE, PERSONAL INJURY OR DEATH.

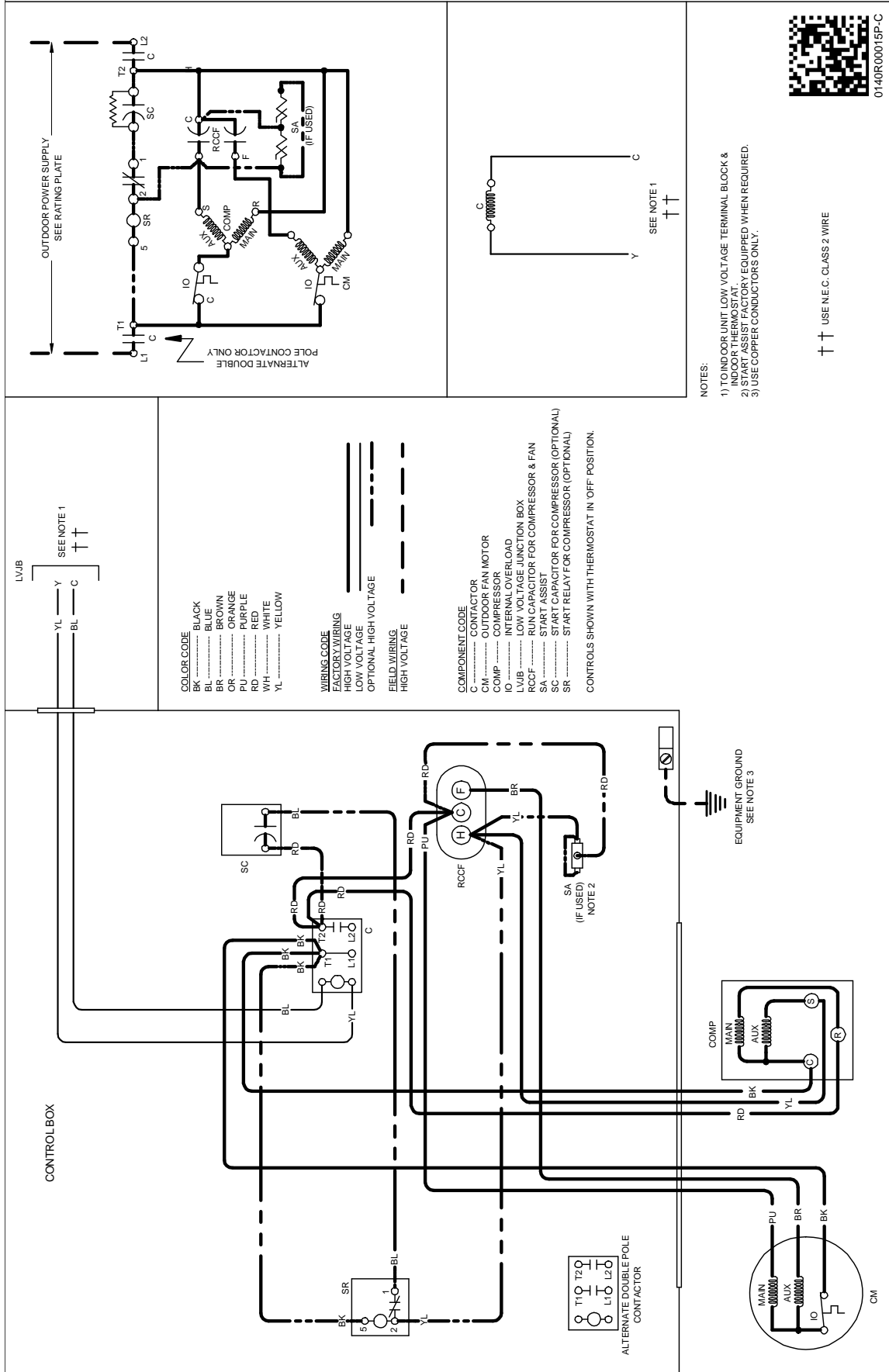

Wiring is subject to change. Always refer to the wiring diagram on the unit for the most up-to-date wiring.

WARNING
HIGH VOLTAGE!
 DISCONNECT ALL POWER BEFORE SERVICING OR INSTALLING THIS UNIT. MULTIPLE POWER SOURCES MAY BE PRESENT. FAILURE TO DO SO MAY CAUSE PROPERTY DAMAGE, PERSONAL INJURY OR DEATH.

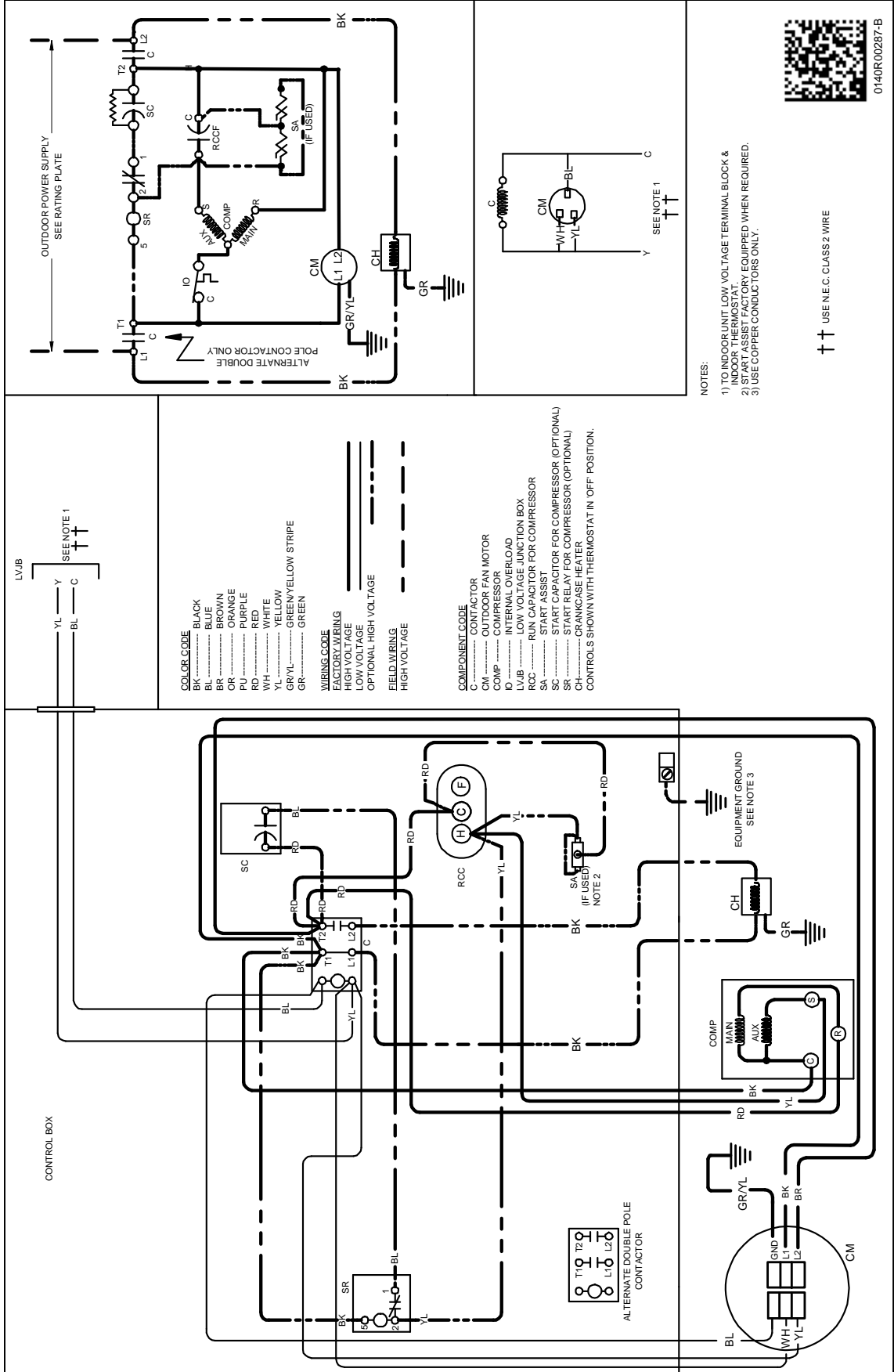

0140R00287-B

Wiring is subject to change. Always refer to the wiring diagram on the unit for the most up-to-date wiring.



WARNING
 HIGH VOLTAGE!
 DISCONNECT ALL POWER BEFORE SERVICING OR INSTALLING THIS UNIT. MULTIPLE POWER SOURCES MAY BE PRESENT. FAILURE TO DO SO MAY CAUSE PROPERTY DAMAGE, PERSONAL INJURY OR DEATH.

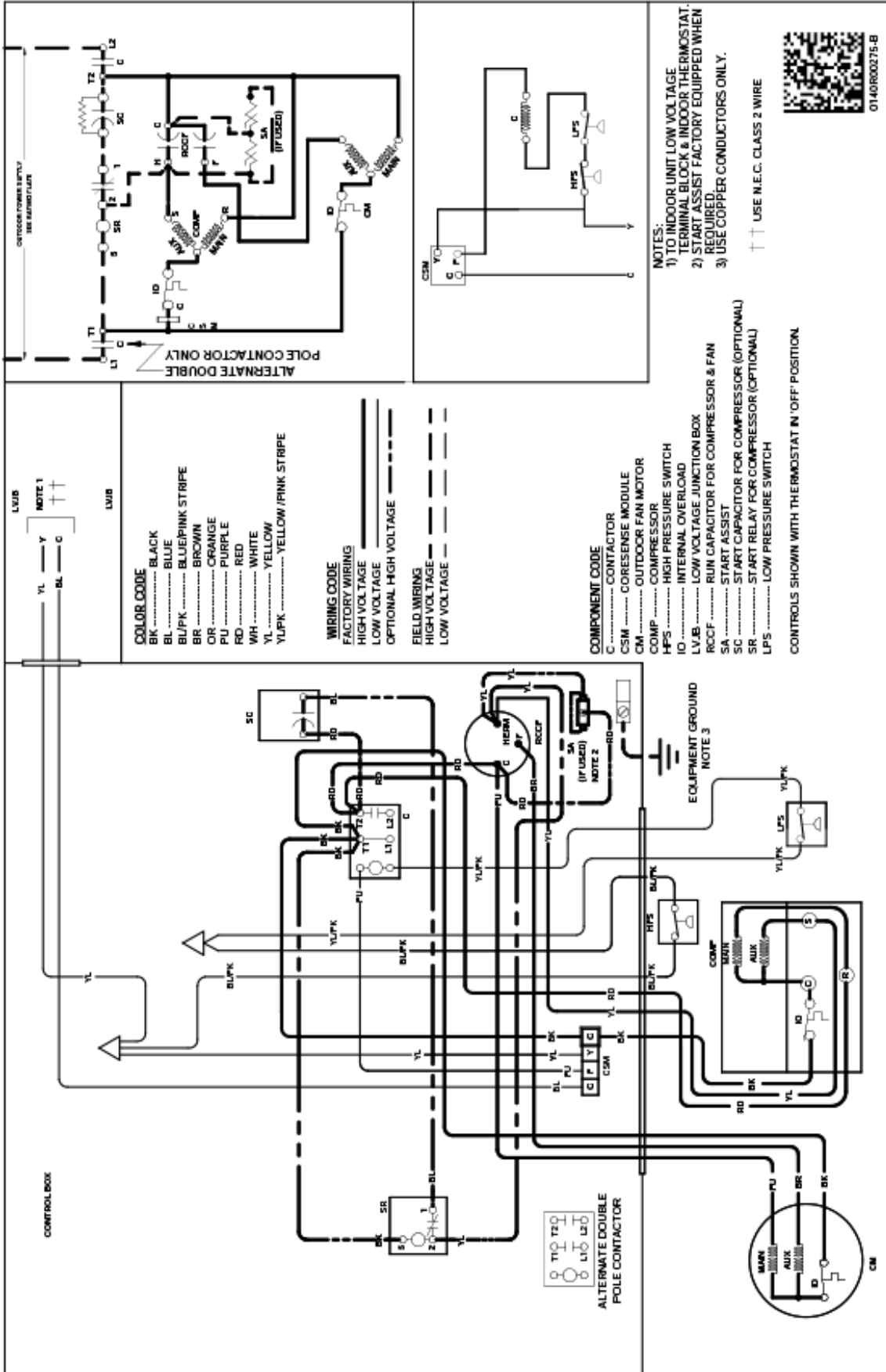

Wiring is subject to change. Always refer to the wiring diagram on the unit for the most up-to-date wiring.



WARNING
HIGH VOLTAGE!
 DISCONNECT ALL POWER BEFORE SERVICING OR INSTALLING THIS UNIT. MULTIPLE POWER SOURCES MAY BE PRESENT. FAILURE TO DO SO MAY CAUSE PROPERTY DAMAGE, PERSONAL INJURY OR DEATH.

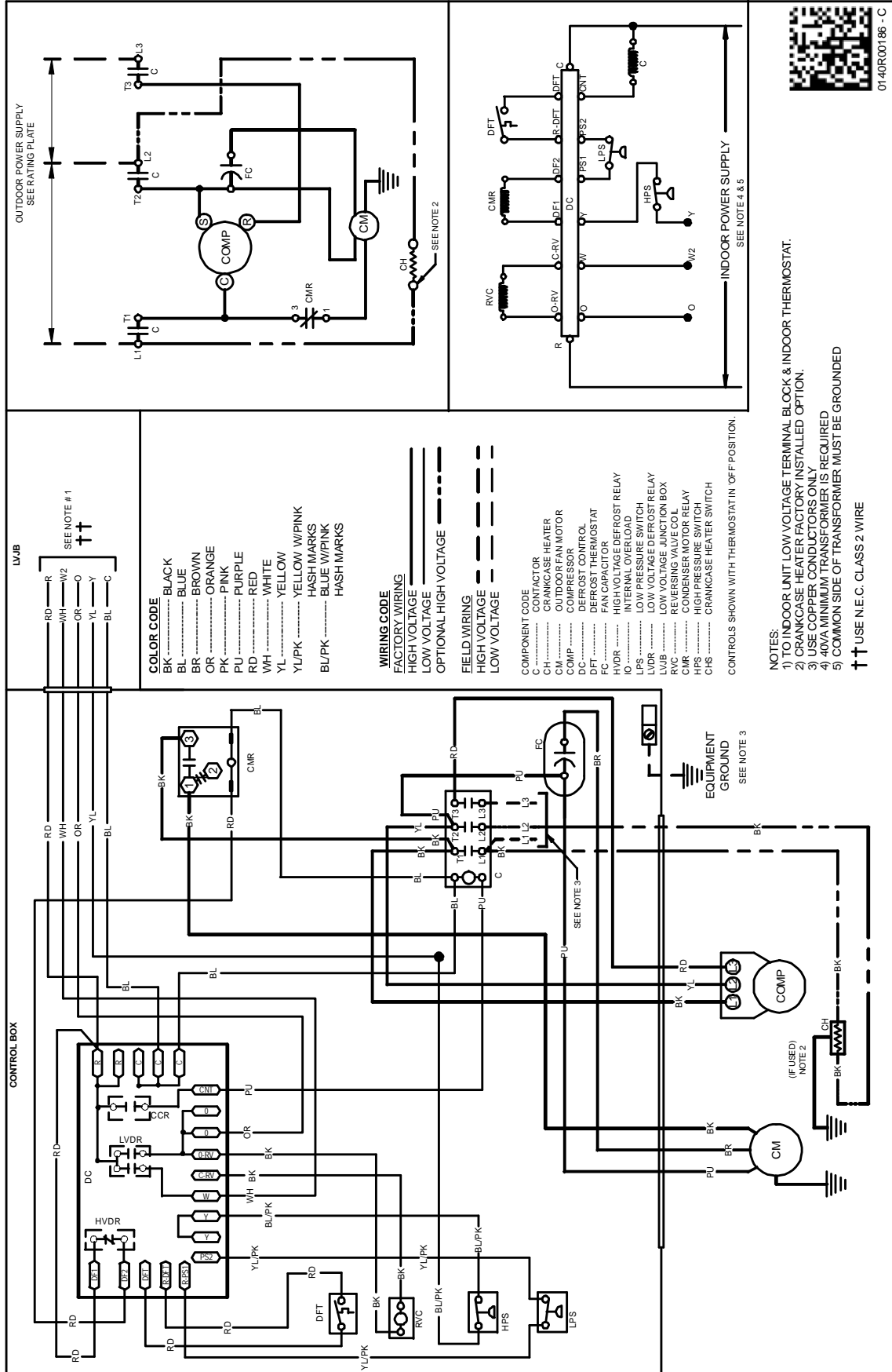

LVJB

RD	R
WH	W2
OR	O
YL	Y
BL	C

SEE NOTE #1
 ††

COLOR CODE

BK	BLACK
BL	BLUE
BR	BROWN
OR	ORANGE
PK	PINK
PU	PURPLE
RD	RED
WH	WHITE
YL	YELLOW
YL/PK	YELLOW W/PINK
WH	WHITE
BL/PK	BLUE W/PINK

HASH MARKS

 HASH MARKS

WIRING CODE

—————	FACTORY WIRING
—————	HIGH VOLTAGE
—————	LOW VOLTAGE
-----	OPTIONAL HIGH VOLTAGE
-----	FIELD WIRING
-----	HIGH VOLTAGE
-----	LOW VOLTAGE

COMPONENT CODE

C	CONTACTOR
CH	CRANKCASE HEATER
CM	OUTDOOR FAN MOTOR
COMP	COMPRESSOR
DC	DEFROST CONTROL
DFT	DEFROST THERMOSTAT
FC	FAN CAPACITOR
HVDR	HIGH VOLTAGE DEFROST RELAY
CR	CRANKCASE HEATER RELAY
LPS	LOW PRESSURE SWITCH
LVDR	LOW VOLTAGE DEFROST RELAY
LVJB	LOW VOLTAGE JUNCTION BOX
RVC	REVERSING VALVE COIL
CMR	CONDENSER MOTOR RELAY
HPS	HIGH PRESSURE SWITCH
CHS	CRANKCASE HEATER SWITCH

CONTROLS SHOWN WITH THERMOSTAT IN "OFF" POSITION.

- NOTES:**
- 1) TO INDOOR UNIT LOW VOLTAGE TERMINAL BLOCK & INDOOR THERMOSTAT.
 - 2) CRANKCASE HEATER FACTORY INSTALLED OPTION.
 - 3) USE COPPER CONDUCTORS ONLY.
 - 4) 40VA MINIMUM TRANSFORMER IS REQUIRED
 - 5) COMMON SIDE OF TRANSFORMER MUST BE GROUNDED
- †† USE N.E.C. CLASS 2 WIRE



0140R00186 - C

Wiring is subject to change. Always refer to the wiring diagram on the unit for the most up-to-date wiring.

WIRING DIAGRAMS



WARNING
 HIGH VOLTAGE!
 DISCONNECT ALL POWER BEFORE SERVICING OR INSTALLING THIS UNIT. MULTIPLE POWER SOURCES MAY BE PRESENT. FAILURE TO DO SO MAY CAUSE PROPERTY DAMAGE, PERSONAL INJURY OR DEATH.

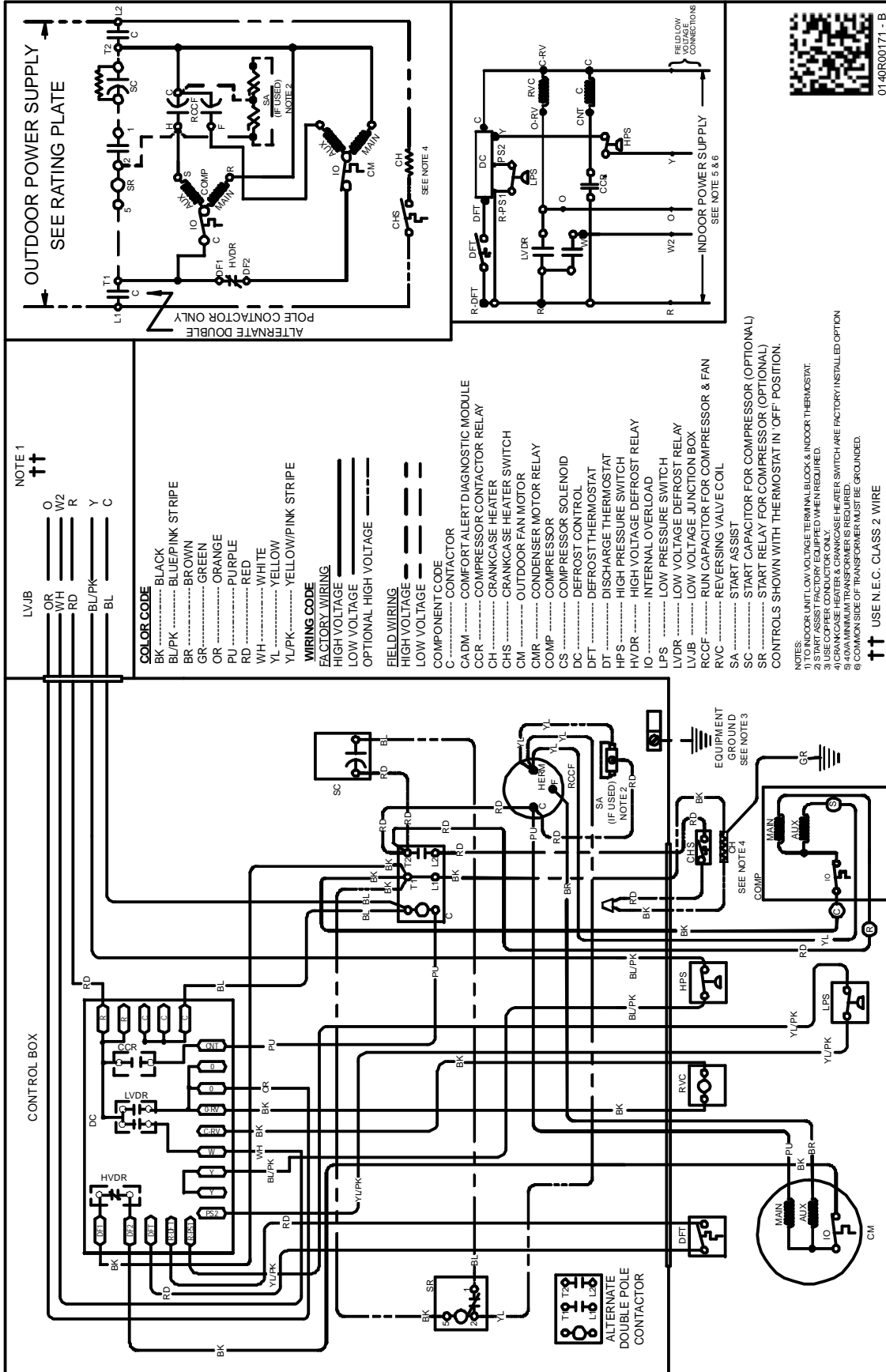

01-40R00171 - B

Wiring is subject to change. Always refer to the wiring diagram on the unit for the most up-to-date wiring.



WARNING
 HIGH VOLTAGE!
 DISCONNECT ALL POWER BEFORE SERVICING OR INSTALLING THIS UNIT. MULTIPLE POWER SOURCES MAY BE PRESENT. FAILURE TO DO SO MAY CAUSE PROPERTY DAMAGE, PERSONAL INJURY OR DEATH.

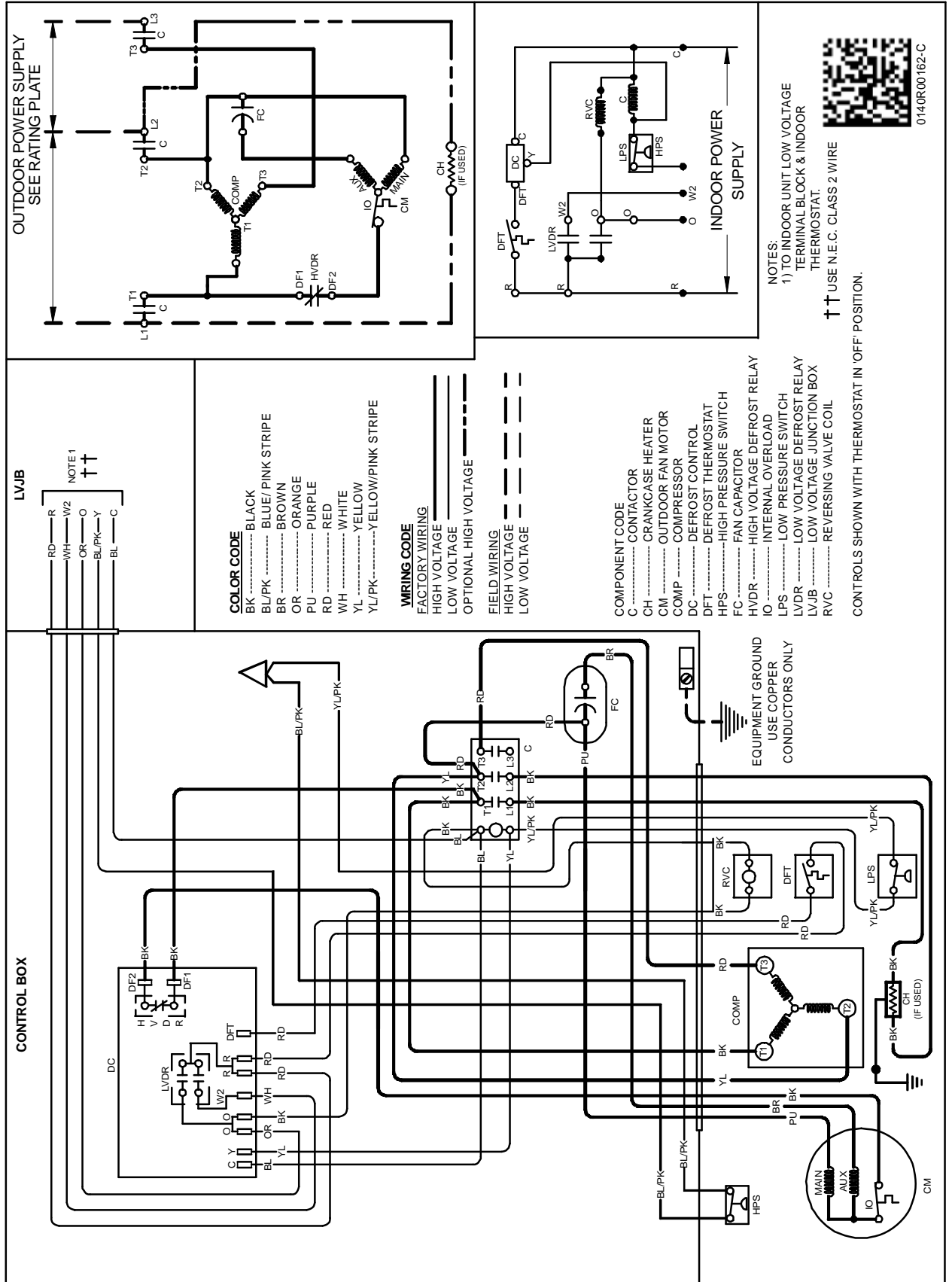

LVJB

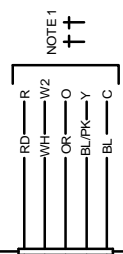

NOTE 1
 ††

- COLOR CODE**
- BK BLACK
 - BL/PK BLUE/PINK STRIPE
 - BR BROWN
 - OR ORANGE
 - PU PURPLE
 - RD RED
 - WH WHITE
 - YL YELLOW
 - YL/PK YELLOW/PINK STRIPE

- WIRING CODE**
- SOLID LINE FACTORY WIRING
 - DASHED LINE HIGH VOLTAGE
 - DASHED LINE WITH DIAGONAL STRIPE LOW VOLTAGE
 - DASHED LINE WITH WAVE STRIPE OPTIONAL HIGH VOLTAGE
 - DASHED LINE WITH DOTTED STRIPE FIELD WIRING
 - DASHED LINE WITH HORIZONTAL STRIPE HIGH VOLTAGE
 - DASHED LINE WITH VERTICAL STRIPE LOW VOLTAGE

- COMPONENT CODE**
- C CONTACTOR
 - CH CRANKCASE HEATER
 - CM OUTDOOR FAN MOTOR
 - COMP COMPRESSOR
 - DC DEFROST CONTROL
 - DFT DEFROST THERMOSTAT
 - HPS HIGH PRESSURE SWITCH
 - FC FAN CAPACITOR
 - HVDR HIGH VOLTAGE DEFROST RELAY
 - IO INTERNAL OVERLOAD
 - LPS LOW PRESSURE SWITCH
 - LVDR LOW VOLTAGE DEFROST RELAY
 - LVJB LOW VOLTAGE JUNCTION BOX
 - RVC REVERSING VALVE COIL

CONTROLS SHOWN WITH THERMOSTAT IN 'OFF' POSITION.

NOTES:
 1) TO INDOOR UNIT LOW VOLTAGE TERMINAL BLOCK & INDOOR THERMOSTAT.
 †† USE N.E.C. CLASS 2 WIRE



014OR00162-C

Wiring is subject to change. Always refer to the wiring diagram on the unit for the most up-to-date wiring.



WARNING
HIGH VOLTAGE!
 DISCONNECT ALL POWER BEFORE SERVICING OR INSTALLING THIS UNIT. MULTIPLE POWER SOURCES MAY BE PRESENT. FAILURE TO DO SO MAY CAUSE PROPERTY DAMAGE, PERSONAL INJURY OR DEATH.

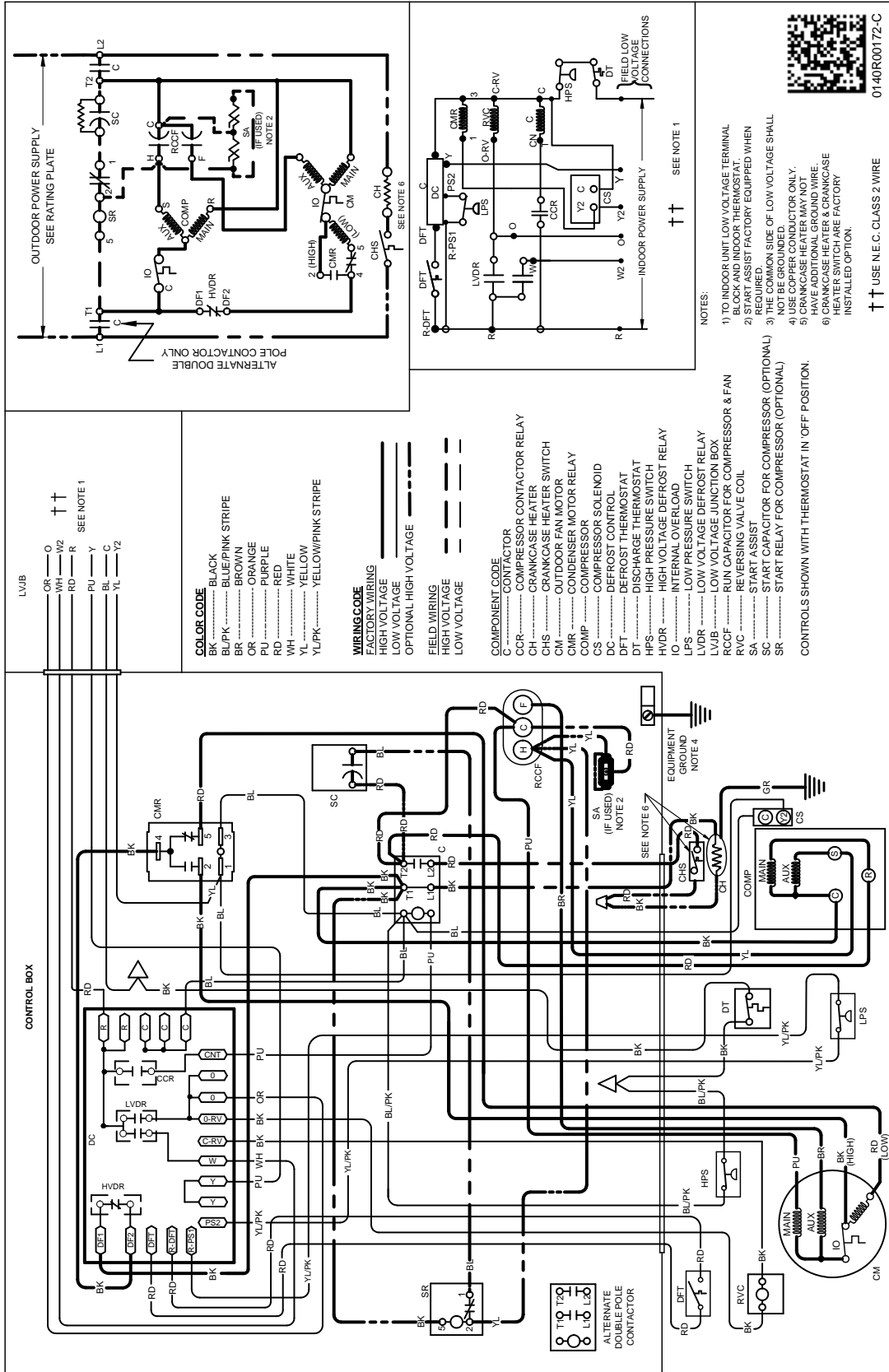

Wiring is subject to change. Always refer to the wiring diagram on the unit for the most up-to-date wiring.

WARNING
 HIGH VOLTAGE!
 DISCONNECT ALL POWER BEFORE SERVICING OR INSTALLING THIS UNIT. MULTIPLE POWER SOURCES MAY BE PRESENT. FAILURE TO DO SO MAY CAUSE PROPERTY DAMAGE, PERSONAL INJURY OR DEATH.

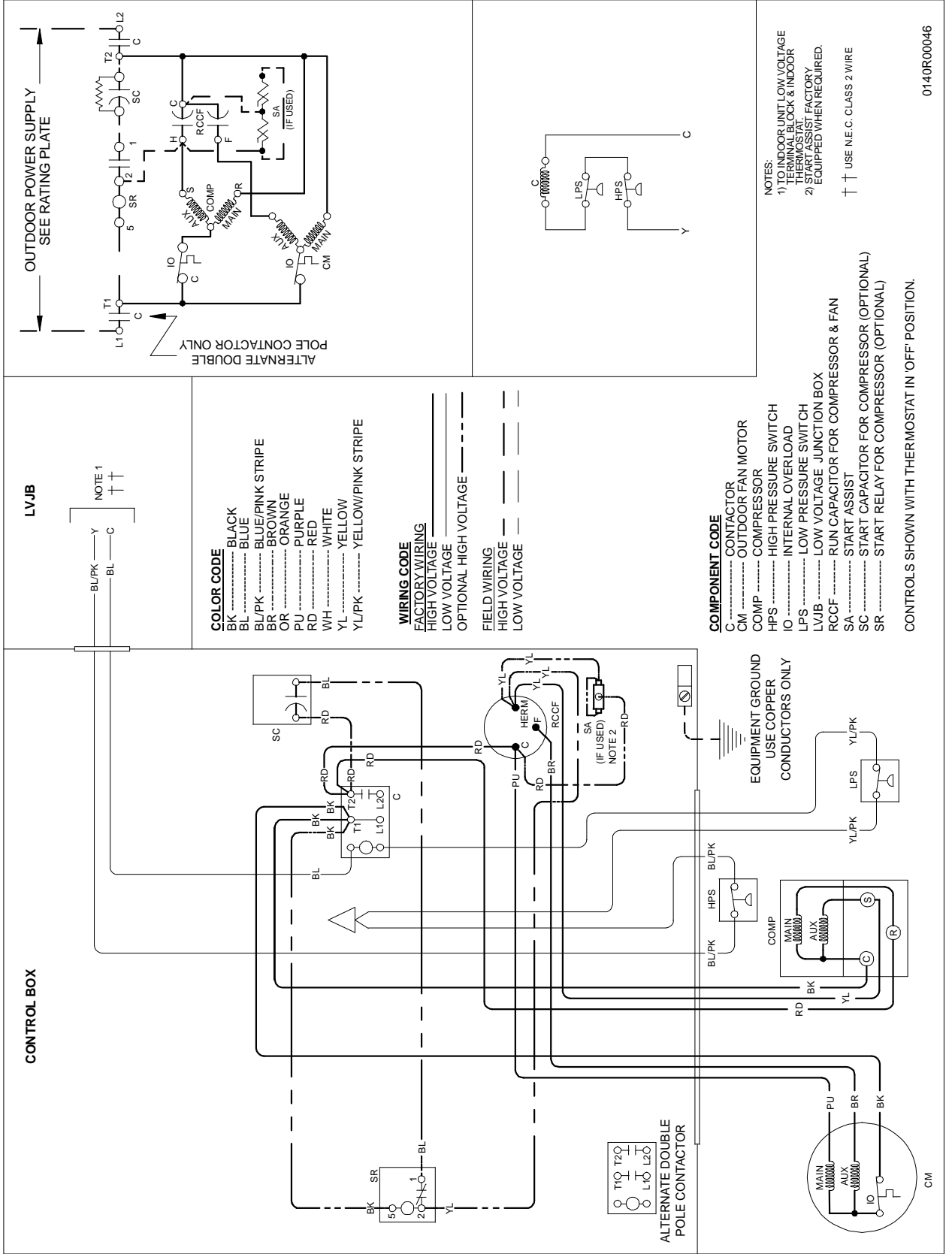

Wiring is subject to change. Always refer to the wiring diagram on the unit for the most up-to-date wiring.

WIRING DIAGRAMS

SSX160[24-48]1A*/B* ; SSX160591AA

WARNING

HIGH VOLTAGE!

DISCONNECT ALL POWER BEFORE SERVICING OR INSTALLING THIS UNIT. MULTIPLE POWER SOURCES MAY BE PRESENT. FAILURE TO DO SO MAY CAUSE PROPERTY DAMAGE, PERSONAL INJURY OR DEATH.

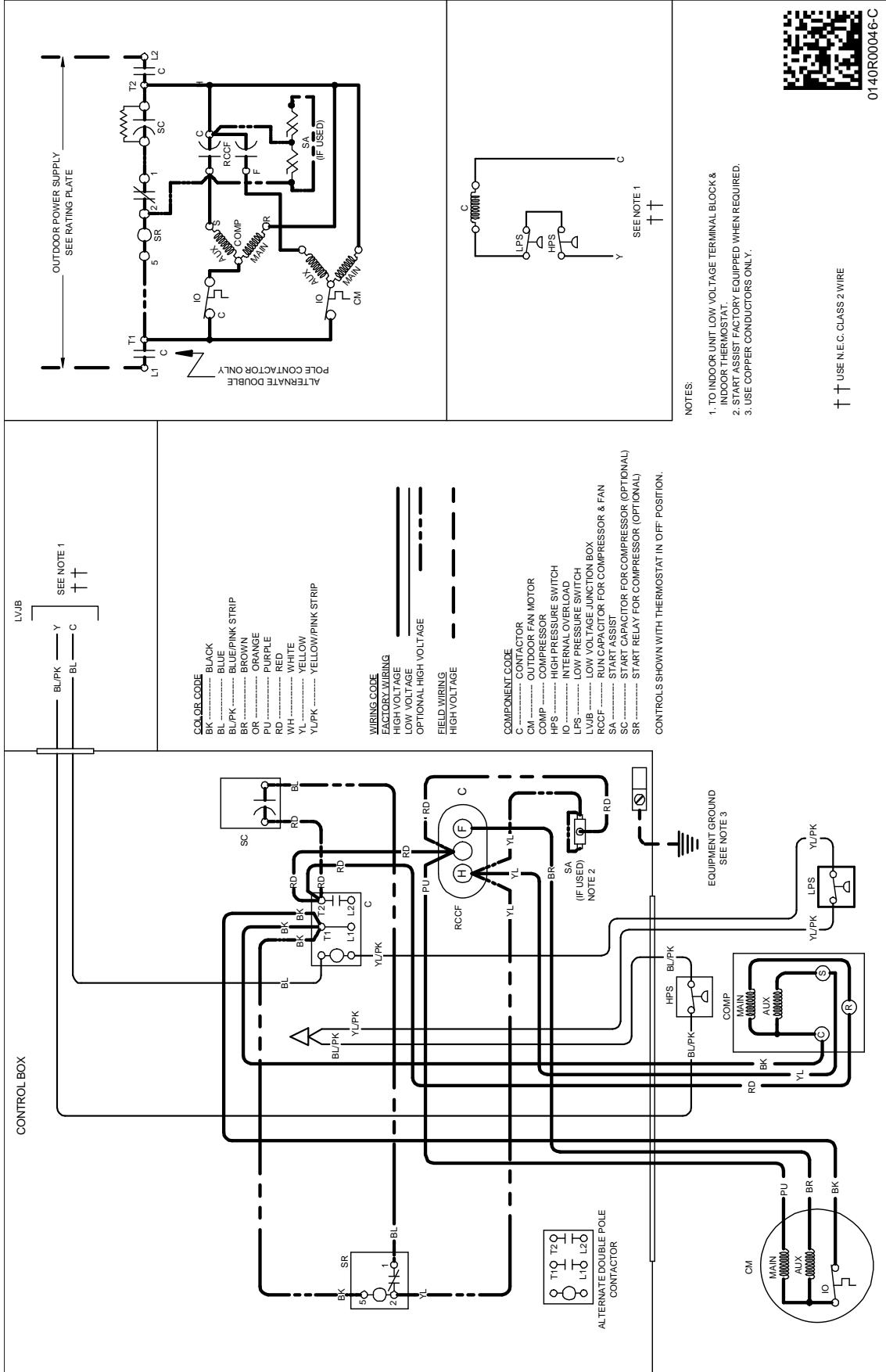

Wiring is subject to change. Always refer to the wiring diagram on the unit for the most up-to-date wiring.



WARNING
HIGH VOLTAGE!
 DISCONNECT ALL POWER BEFORE SERVICING OR INSTALLING THIS UNIT. MULTIPLE POWER SOURCES MAY BE PRESENT. FAILURE TO DO SO MAY CAUSE PROPERTY DAMAGE, PERSONAL INJURY OR DEATH.

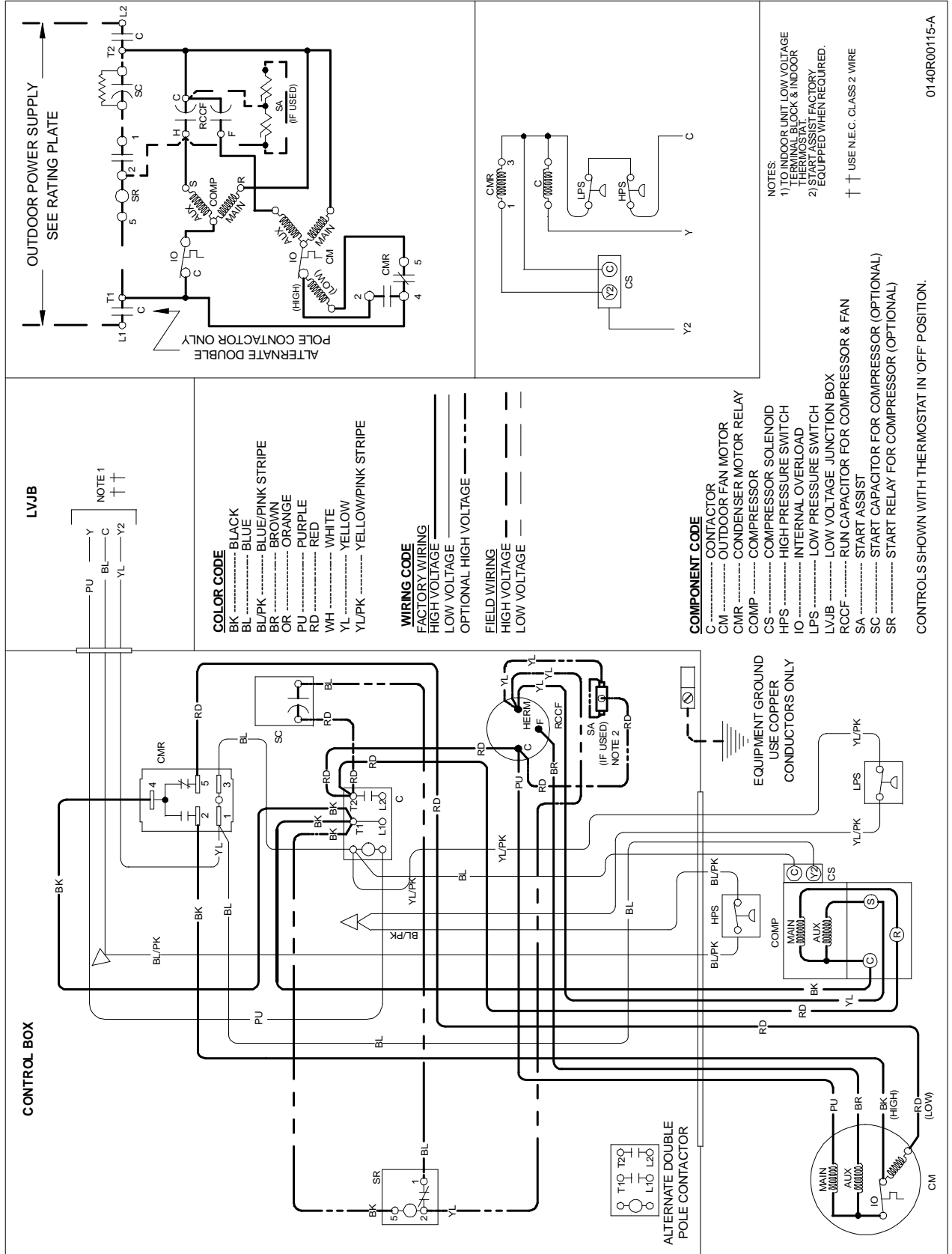

LVIJB

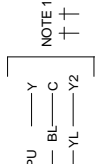

NOTE 1
 † †

COLOR CODE

- BK BLACK
- BL BLUE
- BL/PK BLUE/PINK STRIPE
- BR BROWN
- OR ORANGE
- PU PURPLE
- RD RED
- WH WHITE
- YL YELLOW
- YL/PK YELLOW/PINK STRIPE

WIRING CODE

- FACILITY WIRING
- HIGH VOLTAGE
- LOW VOLTAGE
- OPTIONAL HIGH VOLTAGE
- FIELD WIRING
- HIGH VOLTAGE
- LOW VOLTAGE

COMPONENT CODE

- C CONTACTOR
- CM OUTDOOR FAN MOTOR
- CMR CONDENSER MOTOR RELAY
- COMP COMPRESSOR
- CS COMPRESSOR SOLENOID
- HPS HIGH PRESSURE SWITCH
- IO INTERNAL OVERLOAD
- LPS LOW PRESSURE SWITCH
- LVIJB LOW VOLTAGE JUNCTION BOX
- RCCF RUN CAPACITOR FOR COMPRESSOR & FAN
- SA START ASSIST
- SC START CAPACITOR FOR COMPRESSOR (OPTIONAL)
- SR START RELAY FOR COMPRESSOR (OPTIONAL)

CONTROLS SHOWN WITH THERMOSTAT IN OFF POSITION.

NOTES:
 1) TO INDOOR UNIT LOW VOLTAGE THERMOSTAT
 2) START ASSIST FACTORY EQUIPPED WHEN REQUIRED.
 † † USE N.E.C. CLASS 2 WIRE

0140R00115-A

Wiring is subject to change. Always refer to the wiring diagram on the unit for the most up-to-date wiring.



WARNING
HIGH VOLTAGE!
DISCONNECT ALL POWER BEFORE SERVICING OR INSTALLING THIS UNIT. MULTIPLE POWER SOURCES MAY BE PRESENT. FAILURE TO DO SO MAY CAUSE PROPERTY DAMAGE, PERSONAL INJURY OR DEATH.

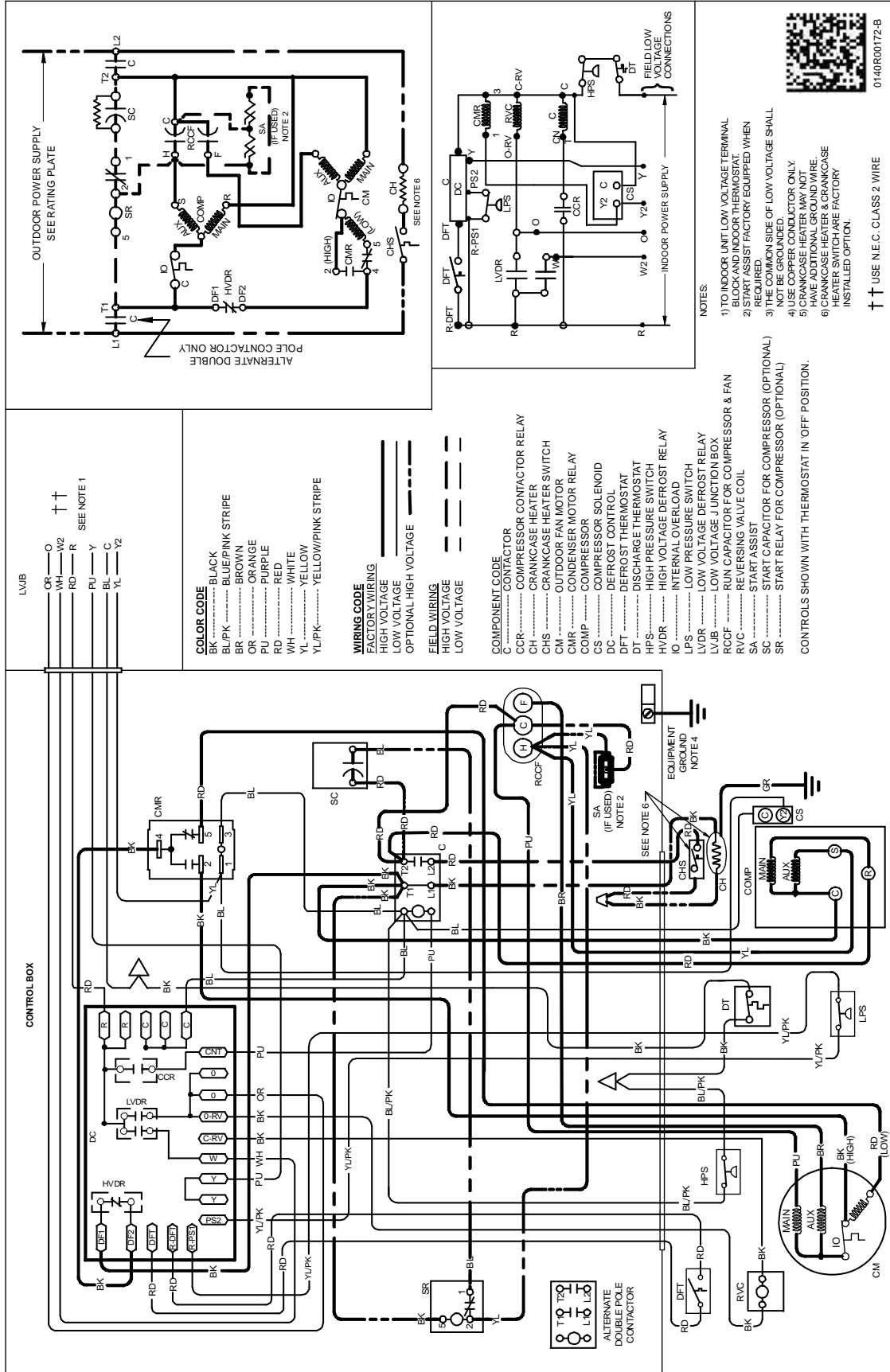

Wiring is subject to change. Always refer to the wiring diagram on the unit for the most up-to-date wiring.

WARNING

HIGH VOLTAGE!
DISCONNECT ALL POWER BEFORE SERVICING OR INSTALLING THIS UNIT. MULTIPLE POWER SOURCES MAY BE PRESENT. FAILURE TO DO SO MAY CAUSE PROPERTY DAMAGE, PERSONAL INJURY OR DEATH.

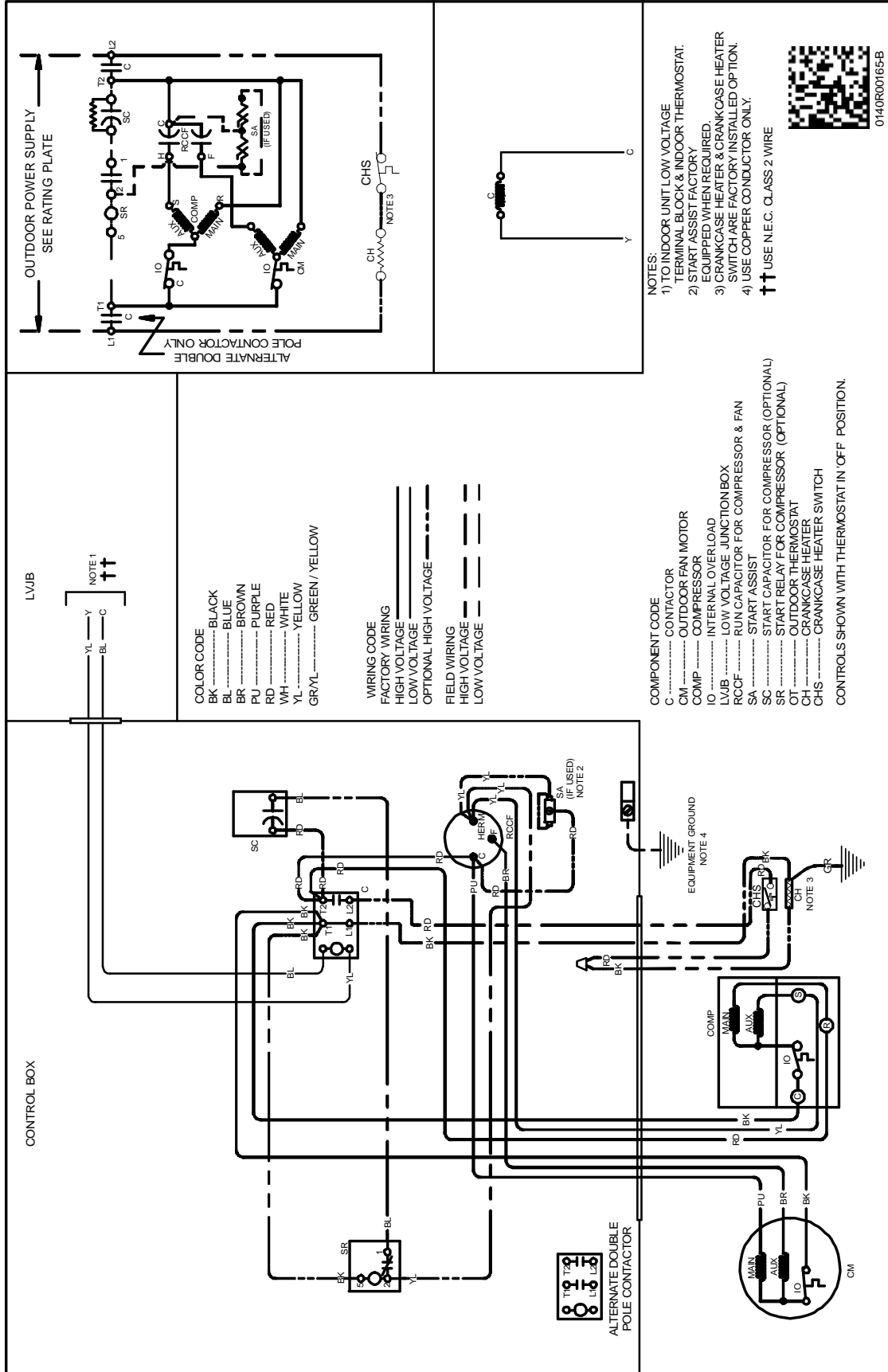

Wiring is subject to change. Always refer to the wiring diagram on the unit for the most up-to-date wiring.



WARNING
HIGH VOLTAGE!
 DISCONNECT ALL POWER BEFORE SERVICING OR INSTALLING THIS UNIT. MULTIPLE POWER SOURCES MAY BE PRESENT. FAILURE TO DO SO MAY CAUSE PROPERTY DAMAGE, PERSONAL INJURY OR DEATH.

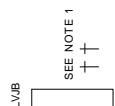
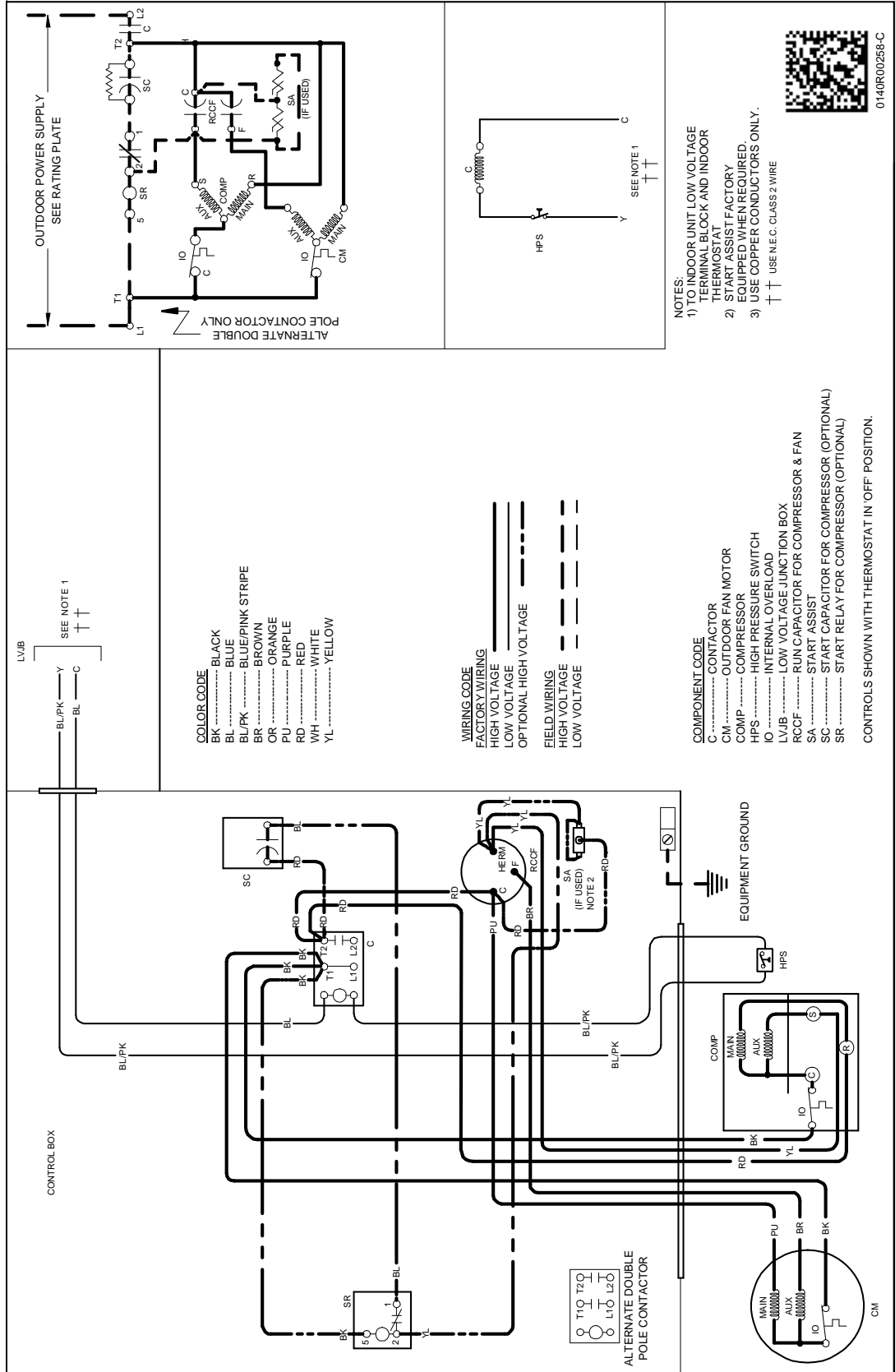

- COLOR CODE**
- BK BLACK
 - BL BLUE
 - BL/PK BLUE/PINK STRIPE
 - BR BROWN
 - CR ORANGE
 - PU PURPLE
 - RD RED
 - WH WHITE
 - YL YELLOW

- WIRING CODE**
- FACTORY WIRING
 - HIGH VOLTAGE
 - LOW VOLTAGE
 - OPTIONAL HIGH VOLTAGE
 - FIELD WIRING
 - HIGH VOLTAGE
 - LOW VOLTAGE

- COMPONENT CODE**
- C CONTACTOR
 - CM OUTDOOR FAN MOTOR
 - COMP COMPRESSOR
 - HPS HIGH PRESSURE SWITCH
 - IO INTERNAL OVERLOAD
 - L.V.B. LOW VOLTAGE JUNCTION BOX
 - RCCF RUN CAPACITOR FOR COMPRESSOR & FAN
 - SA START ASSIST
 - SC START RELAY FOR COMPRESSOR (OPTIONAL)
 - SR START RELAY FOR COMPRESSOR (OPTIONAL)

CONTROLS SHOWN WITH THERMOSTAT IN 'OFF' POSITION.

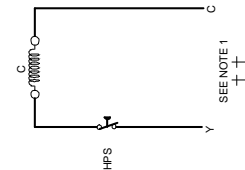
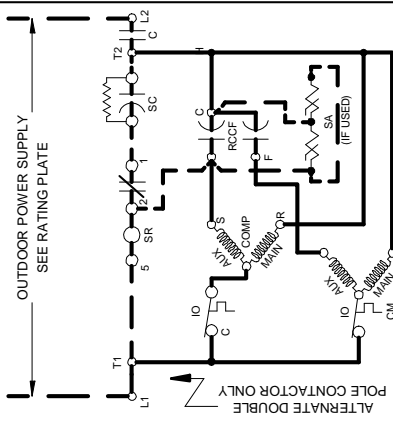

- NOTES:**
- 1) TO INDOOR UNIT LOW VOLTAGE TERMINAL BLOCK AND INDOOR THERMOSTAT
 - 2) START ASSIST FACTORY EQUIPPED WHEN REQUIRED.
 - 3) USE COPPER CONDUCTORS ONLY.
- ↑↑ USE N.E.C. CLASS 2 WIRE



0140R00265-C

Wiring is subject to change. Always refer to the wiring diagram on the unit for the most up-to-date wiring.

WIRING DIAGRAMS

VSZ130181A[C/D/E/F], VSZ130241B[B/C/D], VSZ130301A[D/E/F/G]
 VSZ130361B[B/C/D], VSZ130421A[C/D/E/F/G], VSZ130481A[C/D],
 VSZ130601AC



WARNING
HIGH VOLTAGE!
 DISCONNECT ALL POWER BEFORE SERVICING OR INSTALLING THIS UNIT. MULTIPLE POWER SOURCES MAY BE PRESENT. FAILURE TO DO SO MAY CAUSE PROPERTY DAMAGE, PERSONAL INJURY OR DEATH.

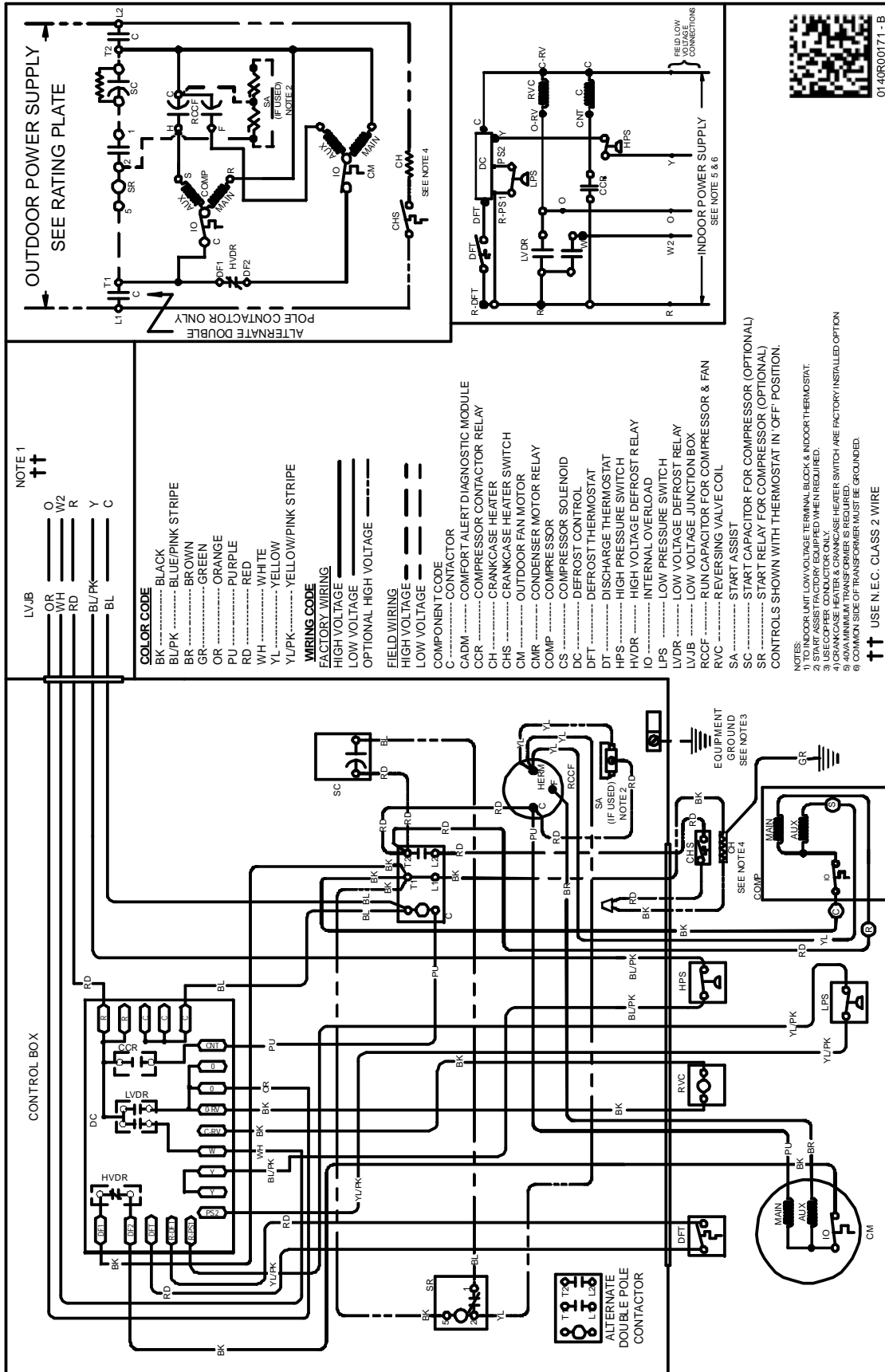

0140R00171-B

Wiring is subject to change. Always refer to the wiring diagram on the unit for the most up-to-date wiring.