

INSTALLATION MANUAL

Middle Static Pressure Duct Type

KDIR
SERIES

KLIMAIRE[®] ≈

Thank you very much for purchasing our air conditioner,
Before using your air conditioner , please read this manual carefully and keep it for future reference.

- If used as MULTI unit, please refer to the Installation & operation manuals packed with outdoor unit.

CONTENTS

PAGE

SAFETY PRECAUTIONS.....	1
INSTALLATION INFORMATION.....	2
ATTACHED FITTINGS.....	3
INSPECTING AND HANDLING THE UNIT.....	4
INDOOR UNIT INSTALLATION.....	4
OUTDOOR UNIT INSTALLATION.....	11
INSTALL THE CONNECTING PIPE.....	15
REFRIGERANT PIPE.....	16
REFRIGERANT PIPE CONNECTION	17
CONNECTIVE DIAGRAM.....	18
CONNECT THE DRAIN PIPE.....	18
FRESH AIR DUCT INSTALLATION.....	19
CONTROL.....	20
WIRING.....	20
TEST OPERATION.....	21

1. SAFETY PRECAUTIONS

- **Keep this manual where the operator can easily find them.**
- **Read this manual attentively before starting up the units.**
- **For safety reason the operator must read the following cautions carefully.**
- **Installation must be performed in accordance with the requirement of NEC and CEC by authorized personnel only. (Applicable to the North American area only)**

The safety precautions listed here are divided into two categories.



WARNING

If you do not follow these instructions exactly, the unit may cause property damage, personal injury or loss of life.



CAUTION

If you do not follow these instructions exactly, the unit may cause minor or moderate property damage, personal injury.

After completing the installation, make sure that the unit operates properly during the start-up operation. Please instruct the customers on how to operate the unit and keep it maintained. Also, inform customers that they should store this installation manual along with the owner's manual for future reference.



WARNING

Be sure only trained and qualified service personnel to install, repair or service the equipment.

Improper installation, repair, and maintenance may result in electric shocks, short-circuit, leaks, fire or other damage to the equipment.

Install according to this installation instructions strictly. If installation is defective, it will cause water leakage, electrical shock and fire.

When installing the unit in a small room, take measures against to keep refrigerant concentration from exceeding allowable safety limits in the event of refrigerant leakage. Contact the place of purchase for more information. Excessive refrigerant in a closed ambient can lead to oxygen deficiency.

Use the attached accessories parts and specified parts for installation. otherwise, it will cause the set to fall, water leakage, electrical shock and fire.

Install at a strong and firm location which is able to withstand the set's weight. If the strength is not enough or installation is not properly done, the set will drop to cause injury.

The appliance must be installed 2.3m / 7.5ft above floor.

The appliance shall not be installed in the laundry.

Before obtaining access to terminals, all supply circuits must be disconnected.

The appliance must be positioned so that the plug is accessible.

The enclosure of the appliance shall be marked by word, or by symbols, with the direction of the fluid flow.

For electrical work, follow the local national wiring standard, regulation and this installation instructions. An independent circuit and single outlet must be used. If electrical circuit capacity is not enough or defect in electrical work, it will cause electrical shock or fire.

Use the specified cable and connect tightly and clamp the cable so that no external force will be acted on the terminal. If connection or fixing is not perfect, it will cause heat-up or fire at the connection.

Wiring routing must be properly arranged so that control board cover is fixed properly. If control board cover is not fixed perfectly, it will cause heat-up at connection point of terminal, fire or electrical shock.

If the supply cord is damaged, it must be replaced by the manufacture or its service agent or a similarly qualified person in order to avoid a hazard.

An all-pole disconnection switch having a contact separation of at least 3mm/0.118in in all poles should be connected in fixed wiring.

When carrying out piping connection, take care not to let air substances go into refrigeration cycle. Otherwise, it will cause lower capacity, abnormal high pressure in the refrigeration cycle, explosion and injury.

Do not modify the length of the power supply cord or use of extension cord, and do not share the single outlet with other electrical appliances. Otherwise, it will cause fire or electrical shock.

Carry out the specified installation work after taking into account strong winds, typhoons or earthquakes. Improper installation work may result in the equipment falling and causing accidents.

If the refrigerant leaks during installation, ventilate the area immediately.

Toxic gas may be produced if the refrigerant comes into the place contacting with fire.

The temperature of refrigerant circuit will be high, please keep the interconnection cable away from the copper tube.

After completing the installation work, check that the refrigerant does not leak.

Toxic gas may be produced if the refrigerant leaks into the room and comes into contact with a source of fire, such as a fan heater, stove or cooker.

The appliance shall be installed in accordance with national wiring regulations.

Do not operate your air conditioner in a wet room such as a bathroom or laundry room.

An all-pole disconnection device which has at least 3mm clearances in all poles, and have a leakage current that may exceed 10mA, the residual current device (RCD) having a rated residual operating current not exceeding 30mA, and disconnection must be incorporated in the fixed wiring in accordance with the wiring rules.



CAUTION

Ground the air conditioner.

Do not connect the ground wire to gas or water pipes, lightning rod or a telephone ground wire. Inappropriate grounding may result in electric shocks.

Be sure to install an earth leakage breaker.

Failure to install an earth leakage breaker may result in electric shocks.

Connect the outdoor unit wires, then connect the indoor unit wires.

You are not allowed to connect the air conditioner with the power supply until the wiring and piping is done.

While following the instructions in this installation manual, install drain piping in order to ensure proper drainage and insulate piping in order to prevent condensation.

Improper drain piping may result in water leakage and property damage.

Install the indoor and outdoor units, power supply wiring and connecting wires should be at least 1 meter away from televisions or radios in order to prevent image interference or noise.

Depending on the radio waves, a distance of 1 meter may not be sufficient enough to eliminate the noise.

The appliance is not intended for use by young children or infirm persons without supervision.

Don't install the air conditioner in the following circumstance:

- There is petrolatum existing.
- There is salty air surrounding (near the coast).
- There is caustic gas (the sulfide, for example) existing in the air (near a hot spring).
- The Volt vibrates violently (in the factories).
- In buses or cabinets.
- In kitchen where it is full of oil gas.
- There is strong electromagnetic wave existing.
- There are inflammable materials or gas.
- There is acid or alkaline liquid evaporating.
- Other special conditions.

2. INSTALLATION INFORMATION

- To install properly, please read this "installation manual" at first.
 - The air conditioner must be installed by qualified persons.
 - When installing the indoor unit or its tubing, please follow this manual as strictly as possible.
 - If the air conditioner is installed on a metal part of the building, it must be electrically insulated according to the relevant standards to electrical appliances.
 - When all the installation work is finished, please turn on the power only after a thorough check.
 - Regret for no further announcement if there is any change of this manual caused by product improvement.
-











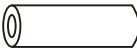

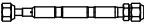

INSTALLATION ORDER

- Select the location;
- Install the indoor unit;
- Install the outdoor unit;
- Install the connecting pipe ;
- Connect the drain pipe;
- Wiring;
- Test operation.

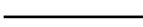
3. ATTACHED FITTINGS

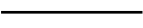
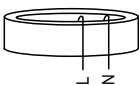
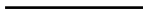
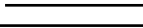
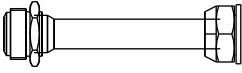
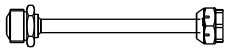
Please check whether the following fittings are of full scope. If there are some spare fittings , please restore them carefully.



Table 3-1

	NAME	SHAPE	QUANTITY
Tubing & Fittings	1. Soundproof / insulation sheath		2
	2. Binding tape		1
	3. Seal sponge		1
	4. Orifice		1 (on some models)
Drainpipe Fittings (for cooling & heating)	5. Drain joint		1
	6. Seal ring		1
Remote controller & Its Frame (Match with remote controller) (for some models)	7. Remote controller		1
	8. Frame		1
	9. Mounting screw(ST2.9x10-C-H)		2
	10. Alkaline dry batteries (AM4)		2
	11. Remote controller manual		1
Wire controller & Its Frame (Match with wire controller) (for some models)	12. Wire controller		1
	13. Wire controller owner's manual		1
	14. Wire controller installation manual		1
EMC & Its Fitting (for some models)	15. Magnetic ring (twist the electric wires L and N around the magnetic ring to five circles)		1
Others	16. Owner's manual		1
	17. Installation manual		1
	18. Transfer connector($\Phi 12.7$ - $\Phi 15.9$)/ ($\Phi 0.5$ in- $\Phi 0.63$ in) (Packed with the indoor unit) (NOTE: Pipe size differ from appliance to appliance. To meet different pipe size requirement, sometimes the pipe connections need the transfer connector to install on the outdoor unit .)		1 (on some models)
	19. Transfer connector($\Phi 6.35$ - $\Phi 9.52$)/ ($\Phi 0.25$ in- $\Phi 0.375$ in) (Packed with the indoor unit) (NOTE: Pipe size differ from appliance to appliance. To meet different pipe size requirement, sometimes the pipe connections need the transfer connector to install on the outdoor unit .)		1 (on some models)
	20. Transfer connector($\Phi 9.52$ - $\Phi 12.7$)/ ($\Phi 0.375$ in- $\Phi 0.5$ in) (Packed with the indoor unit, used for multi-type models only) (NOTE: Pipe size differ from appliance to appliance. To meet different pipe size requirement, sometimes the pipe connections need the transfer connector to install on the outdoor unit .)		1 (on some models)
	21. Connecting wire for display (2M)		1 (on some models)
	22. Cord protection rubber ring		1 (on some models)

4. INSPECTING AND HANDLING THE UNIT

At delivery, the package should be checked and any damage should be reported immediately to the service agent.

When handling the unit, take into account the following:

- 1  Fragile, handle the unit with care.
 Keep the unit upright in order to avoid compressor damage.
- 2 Choose on before hand the path along which the unit is to be brought in.
- 3 Move this unit as originally package as possible.
- 4 When lifting the unit , always use protectors to prevent belt damage and pay attention to the position of the unit's centre of gravity.

5. INDOOR UNIT INSTALLATION

5.1 Installation place

The indoor unit should be installed in a location that meets the following requirements:

- There is enough room for installation and maintenance.
- The ceiling is horizontal, and its structure can endure the weight of the indoor unit.
- The outlet and the inlet are not impeded, and the influence of external air is the least.
- The air flow can reach throughout the room.
- The connecting pipe and drainpipe could be extracted out easily.
- There is no direct radiation from heaters.

Maintenance roomage

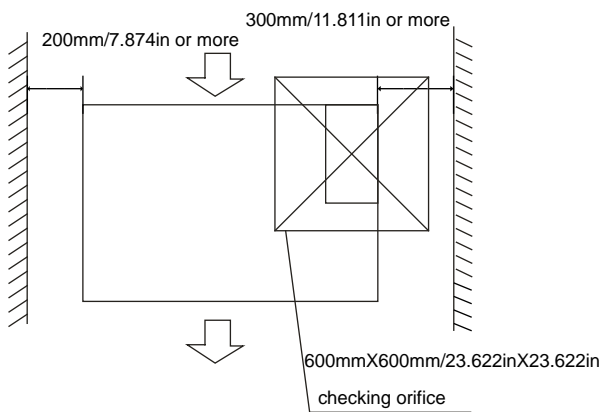

Fig.5-1



CAUTION

Keep indoor unit, outdoor unit, power supply wiring and transmission wiring at least 1 meter away from televisions and radios. This is to prevent image interference and noise in those electrical appliances. (Noise may be generated depending on the conditions under which the electric wave is generated, even if 1 meter is kept.)

5.2 Install the main body

1 Installing $\varnothing 10/\varnothing 0.394$ in hanging screw bolts. (4 bolts)

- Please refer to the following figures for positioning 4 screw bolts.
- Evaluate the ceiling construction and please install with $\varnothing 10 / \varnothing 0.394$ in hanging screw bolts.
- Consult the construction personnels for the specific procedures.
 - Do keep the ceiling flat. Consolidate the roof beam to avoid possible vibration.
- Carry out the pipe and line operation in the ceiling after finishing the installation of the main body. While choosing where to start the operation, determine the direction of the pipes to be drawn out. Especially in case there is a ceiling, position the refrigerant pipes, drain pipes, indoor & outdoor lines to the connection places before hanging up the machine.
- The installation of hanging screw bolts.
 - Cut off the roof beam.
 - Strengthen the place that has been cut off, and consolidate the roof beam.
- After the selection of installation location, position the refrigerant pipes, drain pipes, indoor & outdoor wires to the connection places before hanging up the machine.
- The installation of hanging screw bolts.



NOTE

Confirm the minimum drain tilt is 1/100 or more

5.2.1 Wooden construction

Put the square timber transversely over the roof beam, then install the hanging screw bolts. (Refer to Fig.5-2)

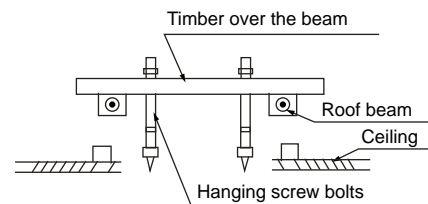

Fig.5-2

5.2.2 New concrete bricks

Inlaying or embedding the screw bolts. (Refer to Fig. 5-3)

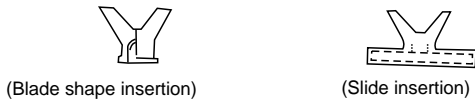

Fig.5-3

5.2.3 For Original concrete bricks

Use embedding screw bold, crock and stick harness. (Refer to Fig.5-4)

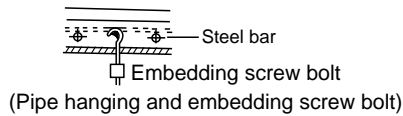

Fig.5-4

5.2.4 Steel roof beam structure

Install and use directly the supporting angle steel. (Refer to Fig.5-5)

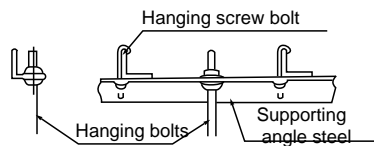

Fig.5-5

2 Overhanging the indoor unit

- (1) Overhang the indoor unit onto the hanging screw bolts with block.
- (2) Position the indoor unit in a flat level by using the level indicator, unless it may cause leakage.

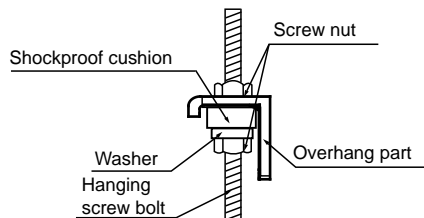

Fig.5-6

5.3 Duct and accessories installation

1. Install the filter(optional) according to air inlet size.
2. Install the canvas tie-in between the body and duct.

3. Air inlet and air outlet duct should be apart far enough to avoid air passage short-circuit.

4. Recommended duct connection

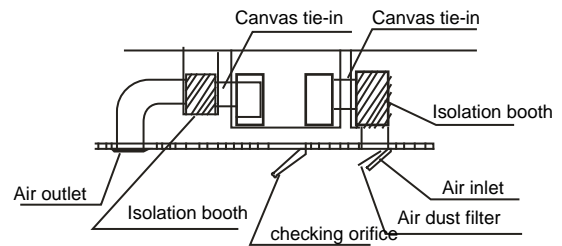

Fig.5-7

5. Please refer to the following static pressure to install

Table.5-1

MODEL (Btu/h)	Static Pressure (Pa)
12	30
18	70
24	70
30~36	80
42~60	100

Change the fan motor static pressure corresponding to external duct static pressure.



NOTE

1. Do not put the connecting duct weight on the indoor unit.
2. When connecting duct, use inflammable canvas tie-in to prevent vibrating.
3. Insulation foam should be wrapped outside the duct to avoid condensate and internal duct underlayer shall be added to reduce the noise for special requirement.

The positioning of ceiling hole, indoor unit and hanging screw bolts

Dimension and air outlet size

Unit: mm

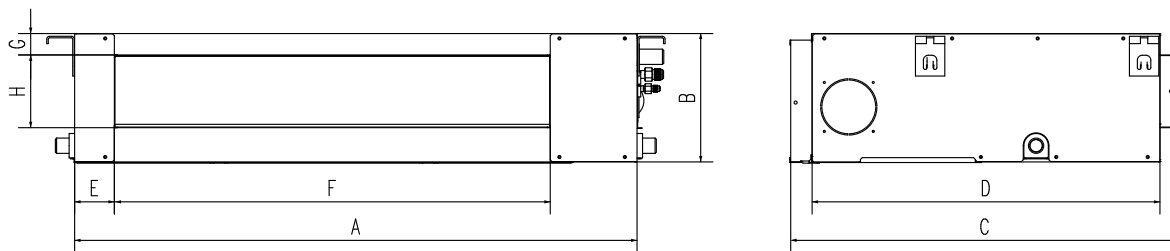

Air inlet size

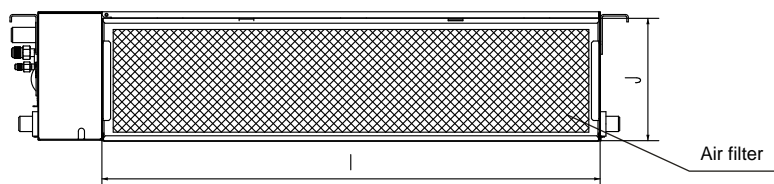

Position size of descensional ventilation opening

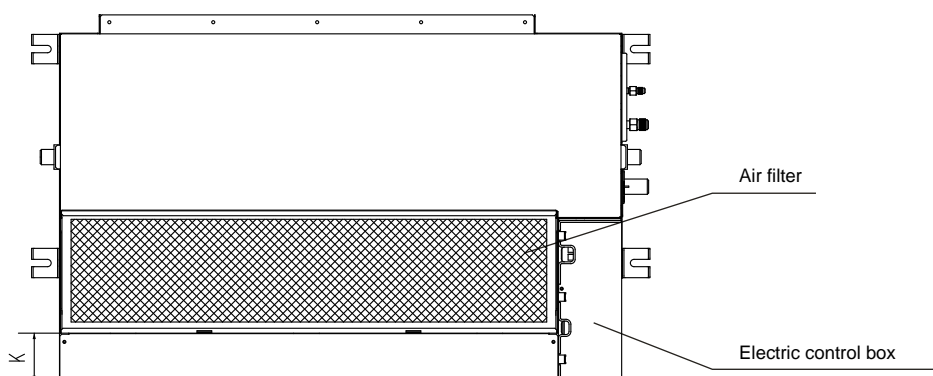

Size of mounted hook

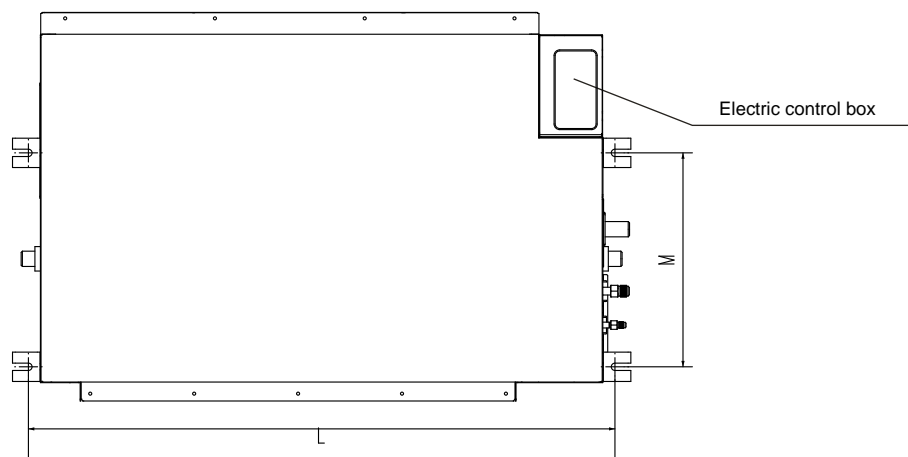

Fig.5-8

	Outline dimension				air outlet opening size				air return opening size			Size of mounted lug	
	A	B	C	D	E	F	G	H	I	J	K	L	M
12	700	210	635	570	65	493	35	119	595	200	80	740	350
12~18	920	210	635	570	65	713	35	119	815	200	80	960	350
24	920	270	635	570	65	713	35	179	815	260	20	960	350
36 (small model)	920	270	635	570	65	713	35	179	815	260	20	1180	490
30~36	1140	270	775	710	65	933	35	179	1035	260	45	1240	500
42~60	1200	300	865	800	80	968	40	204	1094	288	45	1240	500

(in=mm/25.4)

How to adjust the air inlet direction? (From rear side to under-side.)

1. Take off ventilation panel and flange, cut off the staples at side rail.

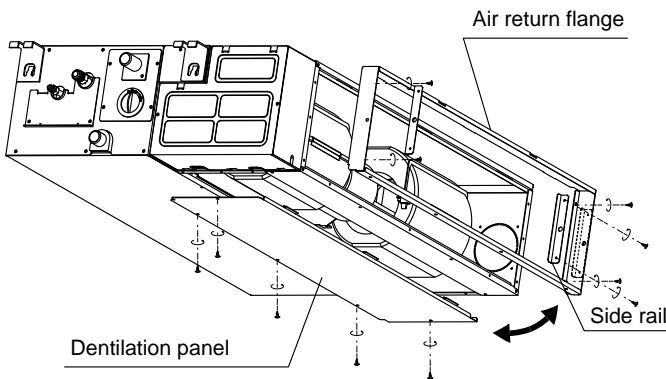

2. Stick the attached seal sponge as per the indicating place in the following fig, and then change the mounting positions of air return panel and air return flange .

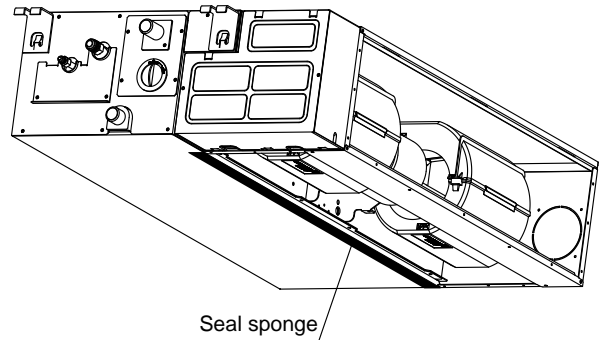

3. When install the filter mesh, please plug it into flange inclined from air return opening, and then push up.

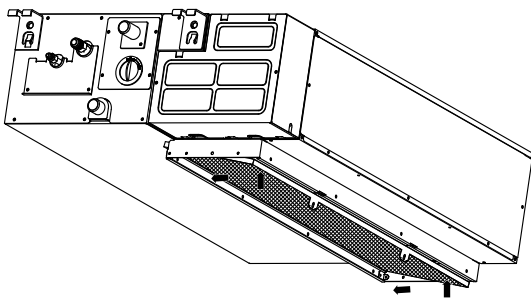

4. The installation has finish, upon filter mesh which fixing blocks have been insert to the flange positional holes.

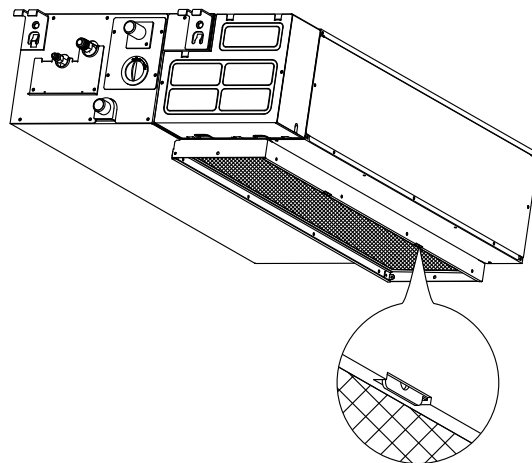

Fig.5-9



NOTE

All the figures in this manual are for explanation purpose only. They may be slightly different from the air conditioner you purchased. The actual unit shall prevail.

5.9 Fan performances

Static pressure curve(middle static pressure duct)

12K

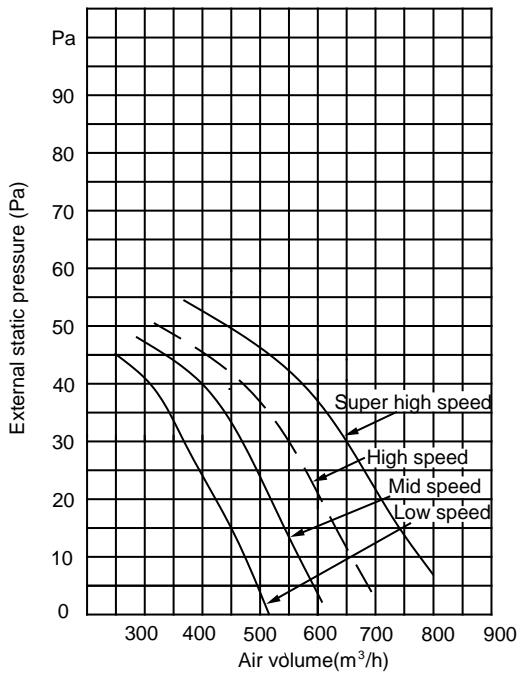

18K

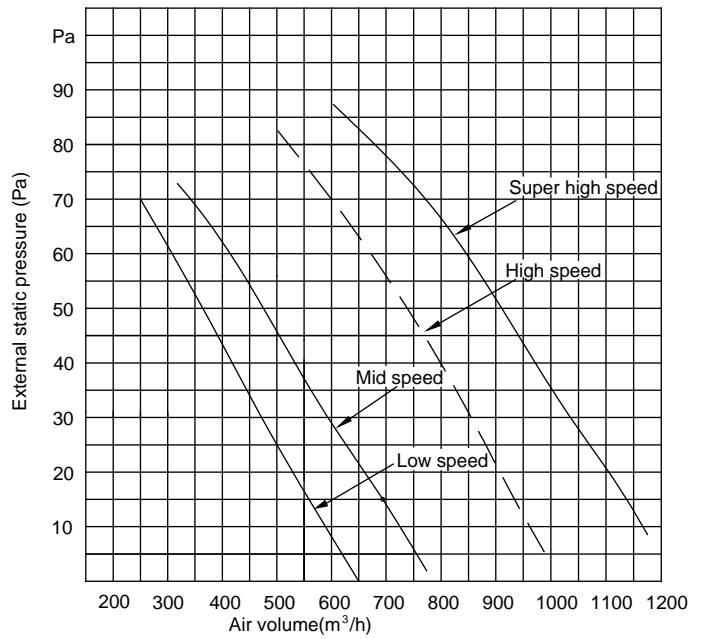

24K

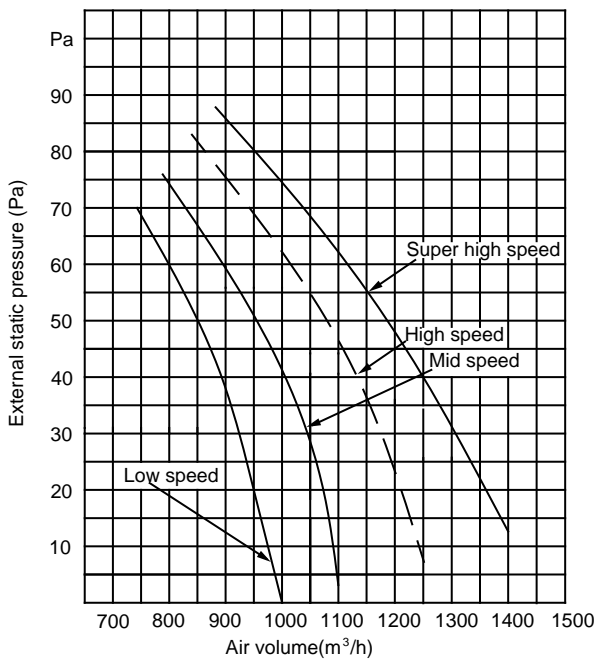

30K

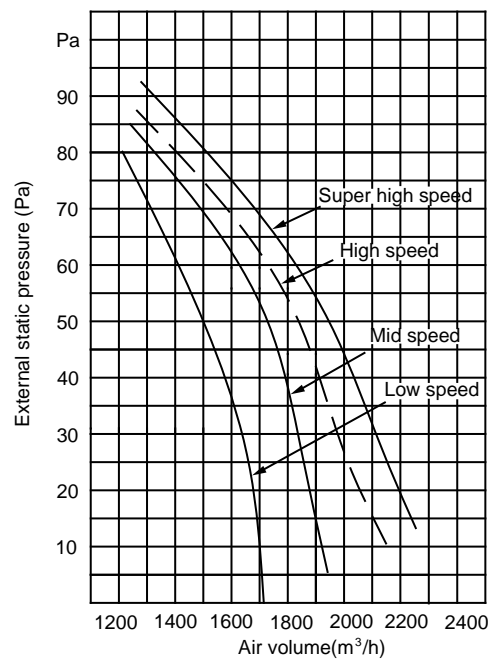

36K

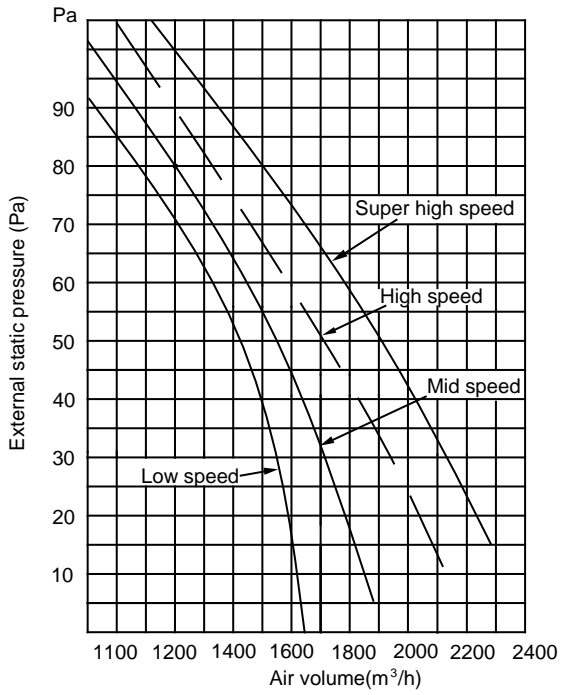

36K(small model)

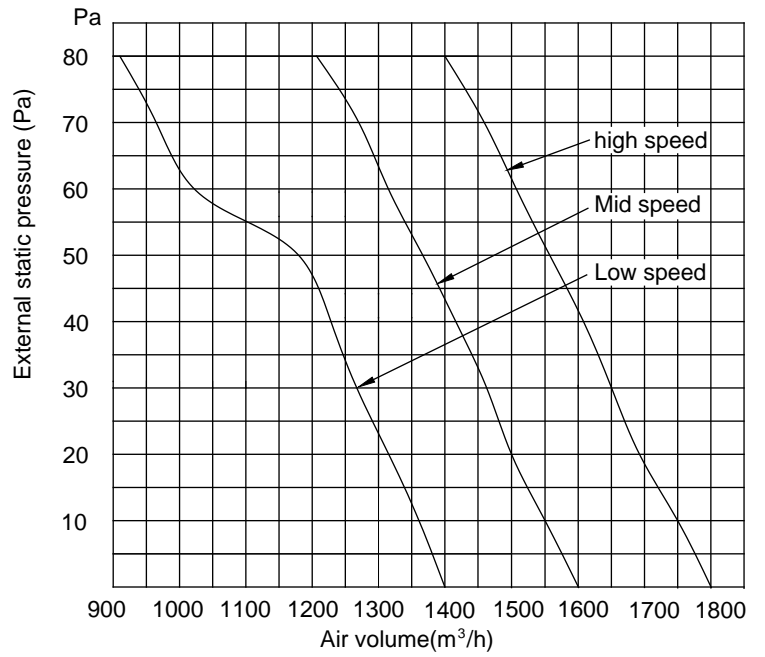

48K

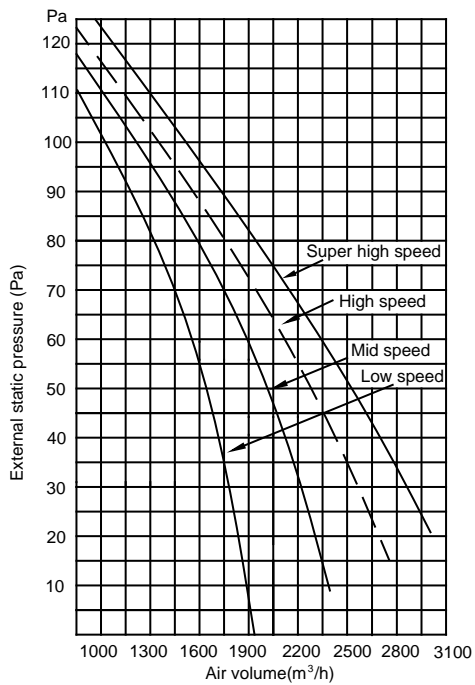

60K

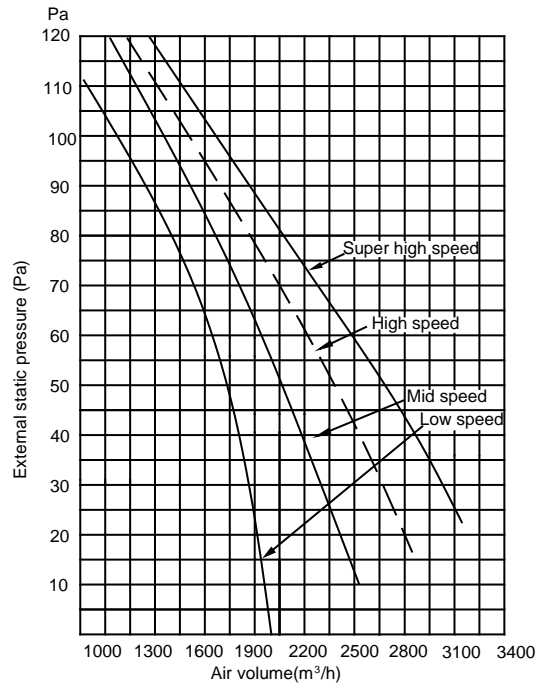

Static pressure curve(high static pressure duct)

18k

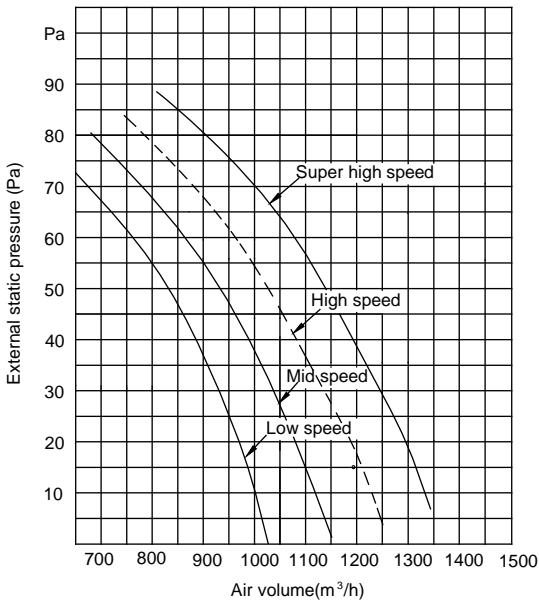

24K

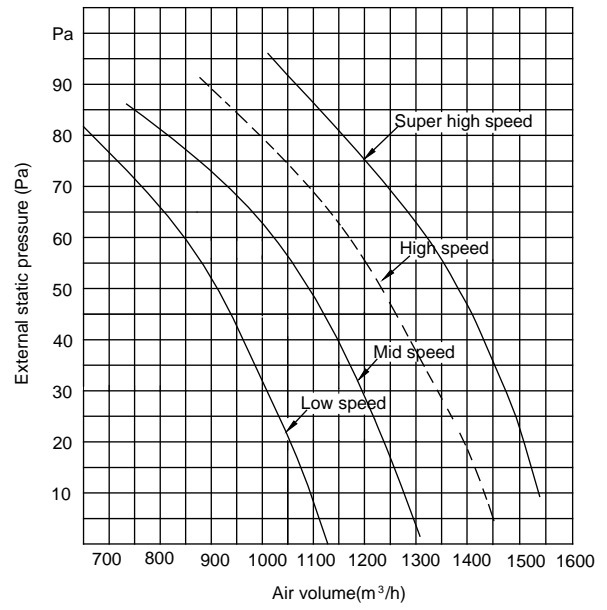

30K

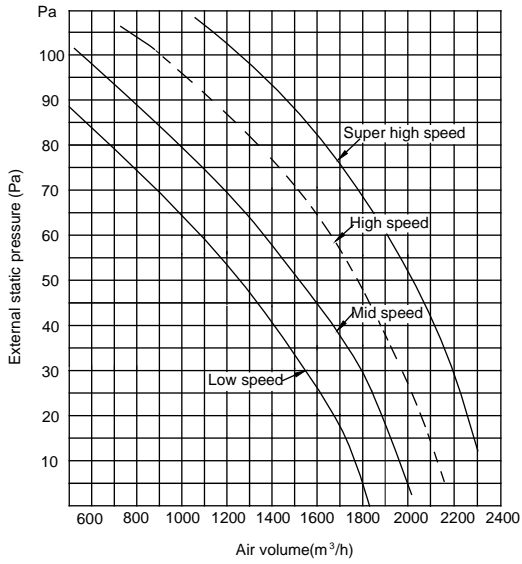

36K

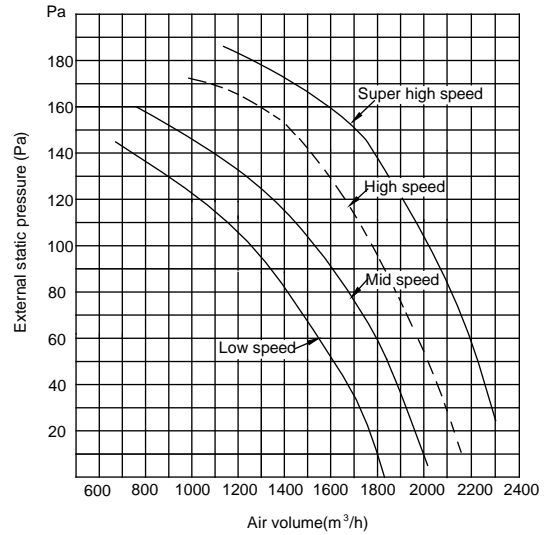

48K

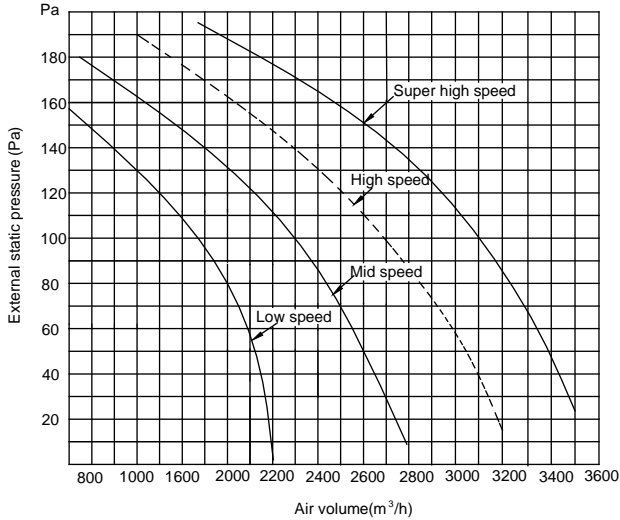

60K

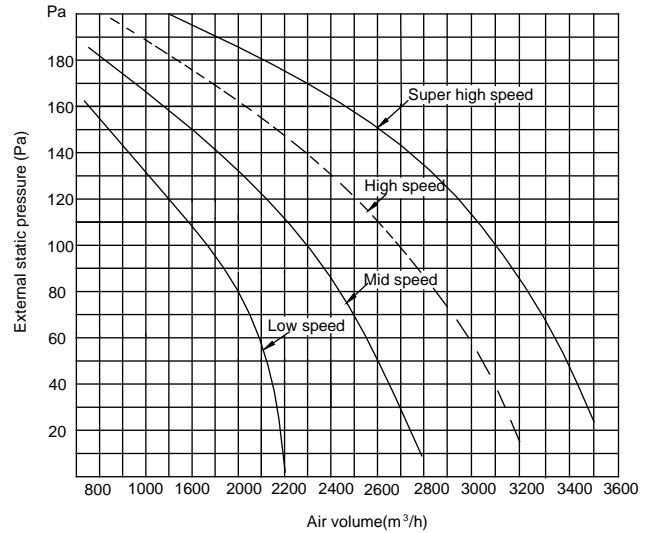

6. OUTDOOR UNIT INSTALLATION

6.1 Installation Place

■ The outdoor unit should be installed in the location that meets the following requirements:

- There is enough room for installation and maintenance.
- The air outlet and the air inlet are not impeded, and can not be reached by strong wind.
- It must be a dry and well ventilating place.
- The support is flat and horizontal and can stand the weight of the outdoor unit. And will no additional noise or vibration.
- Your neighborhood will not feel uncomfortable with the noise or expelled air.
- It is easy to install the connecting pipes or cables.
- Determine the air outlet direction where the discharged air is not blocked.
- There is no danger of fire due to leakage of inflammable gas.
- The piping length between the outdoor unit and the indoor unit may not exceed the allowable piping length.
- In the case that the installation place is exposed to strong wind such as a seaside, make sure the fan operating properly by putting the unit lengthwise along the wall or using a dust shield. (Refer to Fig.6-1)
- If possible, do not install the unit where it is exposed to direct sunlight.
- If necessary, install a blind that does not interfere with the air flow.
- During the heating mode, the water drained off the outdoor unit, The condensate should be well drained away by the drain hole to an appropriate place, so as not to interfere other people.
- Select the position where it will not be subject to snow drifts, accumulation of leaves or other seasonal debris. If unavoidable, please cover it with a shelter.
- Locate the outdoor unit as close to the indoor unit as possible.
- If possible, please remove the obstacles nearby to prevent the performance from being impeded by too little of air circulation.
- The minimum distance between the outdoor unit and obstacles described in the installation chart does not mean that the same is applicable to the situation of an airtight room. Leave open two of the three directions (M,N,P) (Refer to Fig.6-5)

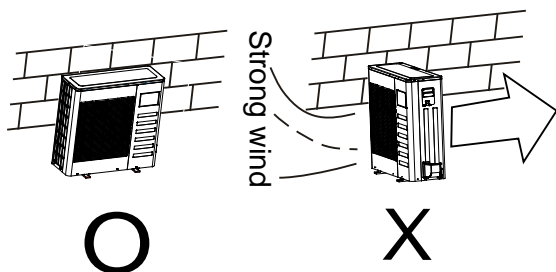

Fig.6-1

6.2 Figure of body size

1. Split type outdoor unit

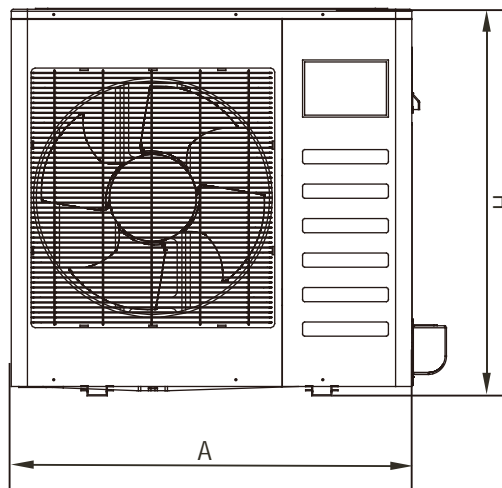

Fig.6-2

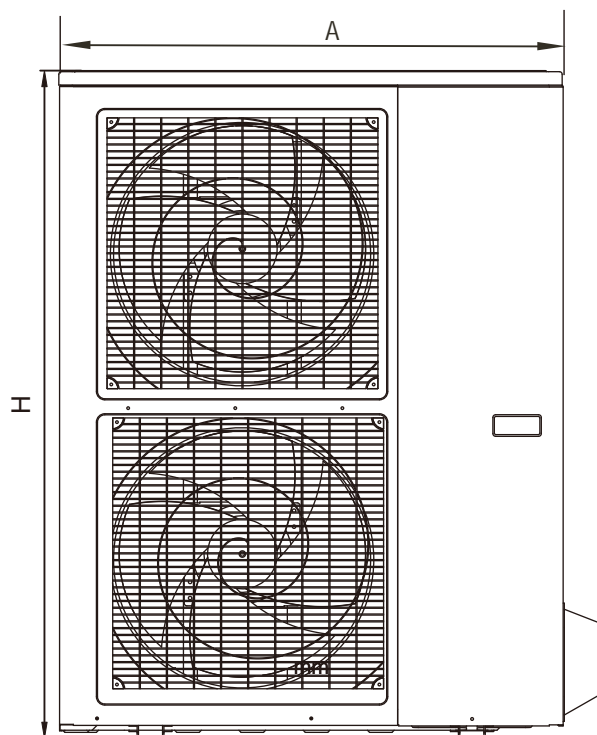

Fig.6-3

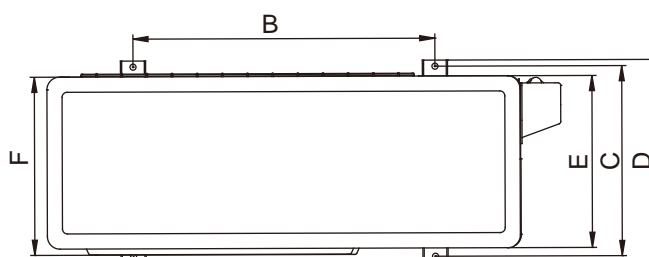

Fig.6-4



NOTE

All the figures in this manual are for explanation purpose only. They may be slightly different from the air conditioner you purchased. The actual unit shall prevail.

Table 6-1

mm

MODEL	A	B	C	D	E	F	H	REMARK
09-36	780	548	266	300	241	250	540	Fig.6-2
	770	487	298	322	260	300	555	Fig.6-2
	800	514	290	340	365	315	333	Fig.6-2
	845	540	350	376	335	340	700	Fig.6-2
	760	530	290	315	270	285	590	Fig.6-2
	845	560	335	360	312	320	700	Fig.6-2
	810	549	325	350	305	310	558	Fig.6-2
	945	640	405	448	385	395	810	Fig.6-2
	900	590	333	355	302	315	860	Fig.6-2
	990	624	366	396	340	345	965	Fig.6-2
	900	590	378	400	330	350	1170	Fig.6-3
42-60	938	634	404	448	368	392	1369	Fig.6-3
	946	673	403	455	405	420	810	Fig.6-2
	950	634	404	448	382	410	1333	Fig.6-3
	990	624	366	396	340	345	965	Fig.6-2
	938	634	404	448	368	392	1369	Fig.6-3
	900	590	378	400	330	350	1170	Fig.6-3

(in=mm/25.4)

2. Vertical discharge type outdoor unit

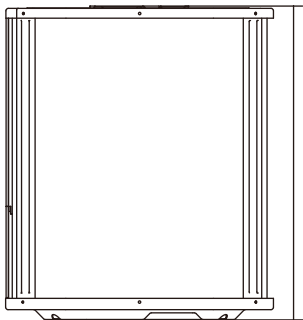

Fig.6-5

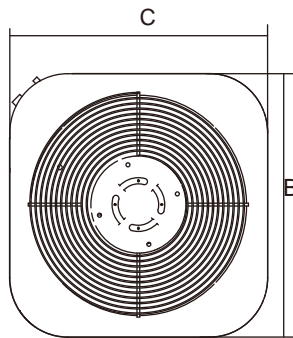

Fig.6-6

Table 6-2

unit: mm

MODEL	DIMENSIONS			REMARK
	A	B	C	
18	633/24.92in	554/21.81in	554/21.81in	Refer to Fig.6-5 Fig.6-6
24	633/24.92in	554/21.81in	554/21.81in	
36	759/29.88in	554/21.81in	554/21.81in	
36	633/24.92in	600/23.62in	600/23.62in	
48	759/29.88in	710/27.95in	710/27.95in	
60	843/33.19in	710/27.95in	710/27.95in	

3. Centrifugal fan type outdoor unit

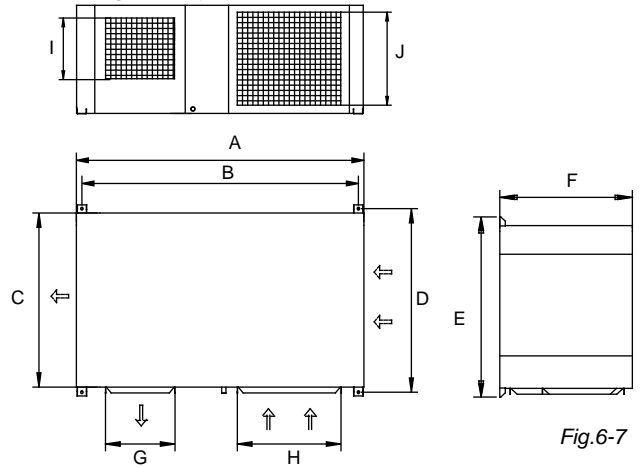

Fig.6-7

Table 6-3

unit: mm

MODEL	A	B	C	D	E	F	G	H	I	J
18	1174	1120	680	720	750	475	300	430	265	393
24	1174	1120	680	720	750	475	300	430	265	393
30	1381	1328	702	740	770	520	336	500	296	443
36	1381	1328	702	740	770	520	336	500	296	443
48	1394	1338	783	820	850	568	398	574	342	463
60	1394	1338	783	820	850	568	398	574	342	463

6.3 Space of installation and maintenance

1. Split type outdoor unit

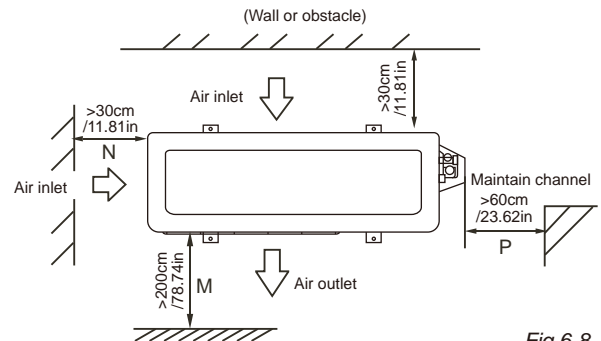

Fig.6-8

2. Vertical discharge type outdoor unit

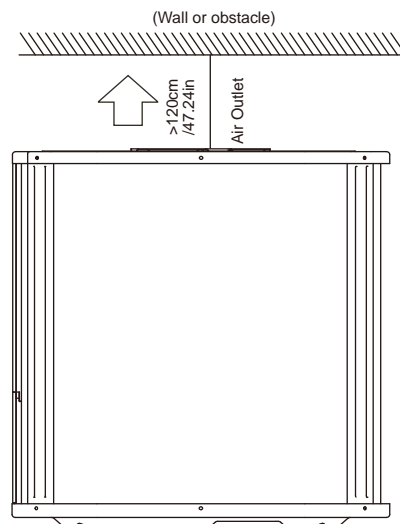

Fig.6-9

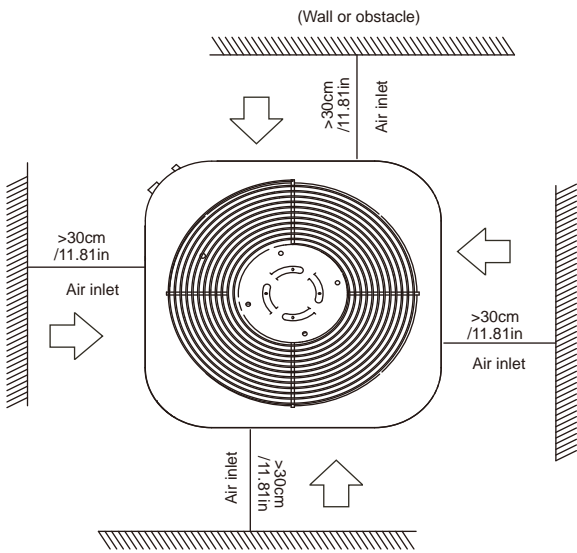

Fig.6-10

3. Centrifugal fan type outdoor unit

a) In case that suspending in the ceiling

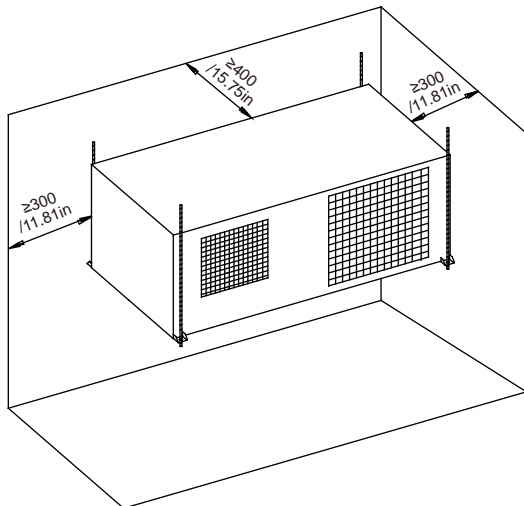

Fig.6-11

b) In case that installing on the floor

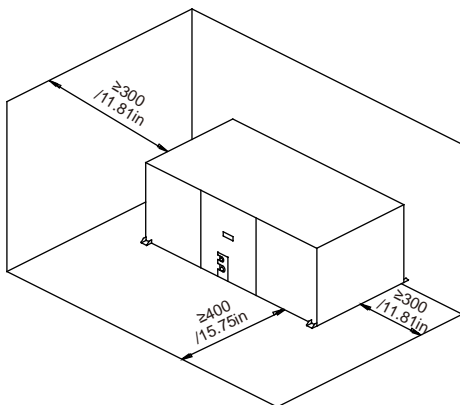

Fig.6-12



NOTE

All the figures in this manual are for explanation purpose only. They may be slightly different from the air conditioner you purchased. The actual unit shall prevail.

6.4 Available configuration for centrifugal fan type outdoor unit

Four different configuration are available for outdoor unit only changing the panels and fan position.



NOTE

Keep in mind that fan unit weight is approx 30kg/1058oz, the unit as well as relevant equipment covered with the vinyl cover during installation work.

■ Air inlet modification

To change air inlet is only necessary to interchange the indicated panels position. Both panels use screws to be fixed to unit chassis.

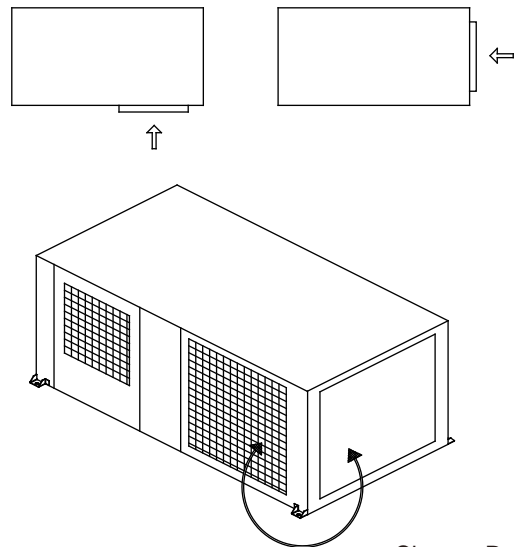

Change Panel
Fig6-13

To change air outlet is necessary to interchange panels too. Fan outlet panel is attached to fan structure, which must be mounted as follow.

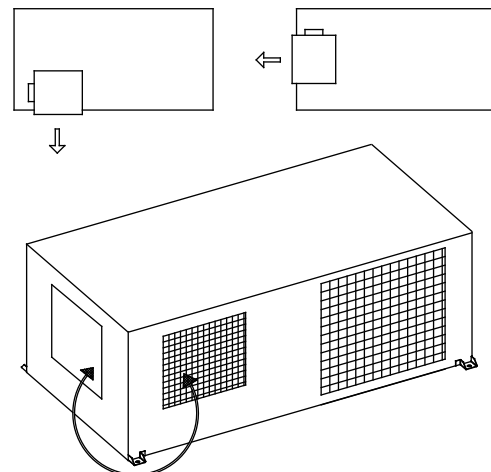

Fig.6-14

6.5 Moving and installation

- Since the gravity center of the unit is not at its physical center, so please be careful when lifting it with a sling.
- Never hold the inlet of the outdoor unit to prevent it from deforming.
- Do not touch the fan with hands or other objects.
- Do not lean it more than 45°, and do not lay it sidelong.
- Make concrete foundation according to the specifications of the outdoor units. (Refer to Fig.6-15)
- Fasten the feet of this unit with bolts firmly to prevent it from collapsing in case of earthquake or strong wind. (Refer to Fig.6-15)

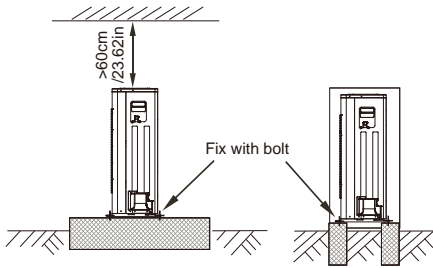

Fig.6-15

■ Concrete Foundation

1. Foundation could be on flat and is recommended be 100-300mm /3.94-11.81in higher than ground level.
2. Install a drainage around foundation for smooth drain
3. When installing the outdoor unit fix the unit by anchor bolts of M10
4. When installing the unit on a roof or a veranda, drain water sometimes turns to ice on the cold weather. Therefore, avoid draining in an area that people often use because it is slippery.

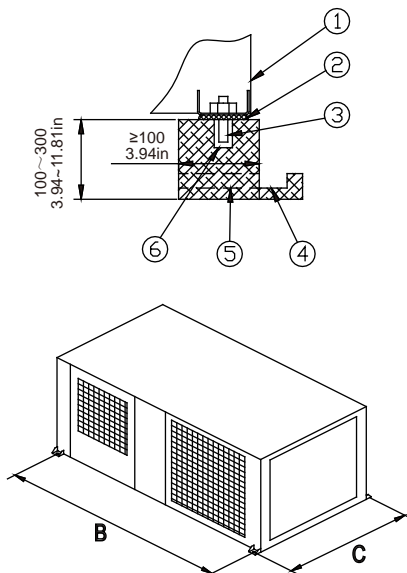

Fig.6-16

Table 6-4

No	Description
①	Outdoor Unit
②	Vibration-proof rubber
③	Anchor Bolt M10
④	Drainage (Wide 100/3.94in×Depth 150/5.9in)
⑤	Drainage
⑥	Mortar Hole (Φ100/3.94in×Depth 150/5.9in)

Table 6-5 unit: mm

MODEL	B	C
18~24	1120/44.1in	720/28.35in
30	1338/52.67in	820/32.28in
36	1338/52.67in	820/32.28in
48~60	1338/52.67in	820/32.28in

■ Suspended unit

1. Suspend the unit as the drawing indicates.
2. Ensure that ceiling can resist the Outdoor unit weight indicated in specification label plate.

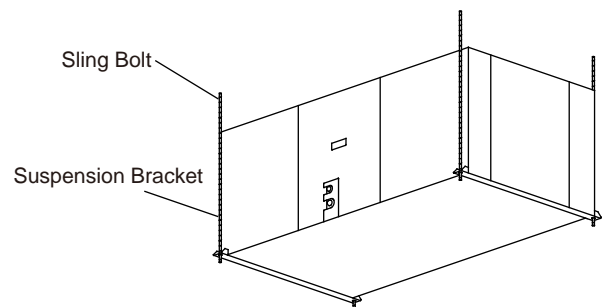

Fig.6-17

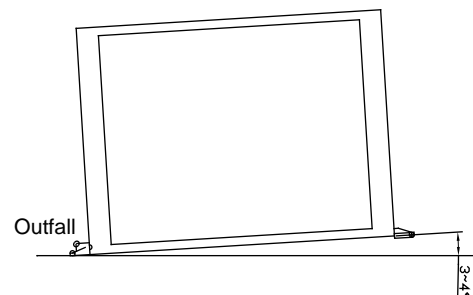

Fig.6-18

NOTE: Make sure 3-4 degree of angel is kept between the unit and the floor when the unit is installed in the low temperature and humid environment.

Make sure the ice on the chassis of the outdoor unit can be dealt with when the unit is installed in the low temperature and humid environment.

The outdoor unit should be installed in mounting rack 30cm /11.81in high. The environment temperature should be above 0°.

The machine must be installed indoor.

7. INSTALL THE CONNECTING PIPE

7.1 Preparation and Caution

Before installation make sure the height difference, the length of refrigerant pipe, and the number of the bends between the indoor unit and outdoor unit meet the following requirements:

Table 7-1

unit:m

The type of models	Model	The length of refrigerant pipe	The max height drop
50Hz T1 condition/R22 Split type air conditioner	12K	15/49.21ft	8/26.25ft
	18K-24K	30/98.42ft	10/32.8ft
	30K-42K	50/164.04ft	20/65.62ft
	48K-60K	50/164.04ft	25/82.02ft
50Hz Vertical discharge air conditioner /60Hz T1 condition/R22 Split type air conditioner and Vertical discharge air conditioner	12K	15/49.21ft	8/26.25ft
	18K-24K	30/98.42ft	10/32.8ft
	30K-60K	30/98.42ft	20/65.62ft
R410A inverter Split type air conditioner and and Centrifugal fan outdoor unit	12K	10/32.8ft	5/16.4ft
	18K-24K	25/82.02ft	12/39.37ft
	30K	25/82.02ft	15/49.21ft
	36K	30/98.42ft	20/65.62ft
	48K-60K	50/164.04ft	25/82.02ft
R410A Split type air conditioner and and Centrifugal fan outdoor unit	12K	15/49.21ft	8/26.25ft
	18K-30K	25/82.02ft	15/49.21ft
	36K	30/98.42ft	20/65.62ft
	48K-60K	50/164.04ft	25/82.02ft
50Hz/60Hz T3 condition (outdoor unit down)	18K-24K	25/82.02ft	10/32.8ft
	30K	30/98.42ft	15/49.21ft
	36K	30/98.42ft	20/65.62ft
	42K-60K	50/164.04ft	25/82.02ft
	18K-24K	25/82.02ft	15/49.21ft
50Hz/60Hz T3 condition (outdoor unit up)	30K	30/98.42ft	20/65.62ft
	36K	30/98.42ft	25/82.02ft
	42K	50/164.04ft	30/98.42ft
	48K-60K	50/164.04ft	35/114.83ft
	12K-18K	5/16.4ft	5/16.4ft

The outdoor unit is charged with rating refrigerant amount in the factory. Additional charge refers to the table below:

Table 7-2

liquid tube(mm)		R410A	R22
Ø6.35	orifice in the indoorunit	0.022kg/mx(L-5)	0.030kg/mx(L-5)
	orifice in the outdoorunit	0.011kg/mx(L-5)	0.015kg/mxL
Ø9.53	orifice in the indoorunit	0.060kg/mx(L-5)	0.065kg/mx(L-5)
	orifice in the outdoorunit	0.030kg/mx(L-5)	0.030kg/mxL
Ø12.7	orifice in the indoorunit	0.110kg/mx(L-5)	0.115kg/mx(L-5)
	orifice in the outdoorunit	0.060kg/mx(L-5)	0.060kg/mxL
Ø15.9	orifice in the indoorunit	0.170kg/mx(L-5)	0.190kg/mx(L-5)
	orifice in the outdoorunit	0.085kg/mx(L-5)	0.095kg/mxL
Ø19.0	orifice in the indoorunit	0.250kg/mx(L-5)	0.290kg/mx(L-5)
	orifice in the outdoorunit	0.125kg/mx(L-5)	0.145kg/mxL

- NOTE:the table above refer to the liquid tube.
- NOTE:The number of bends is up to the length of the max height drop.Usually for each 10m/32.8ft need a bend.



CAUTION

All field piping must be provided by a licensed refrigeration technician and must comply with the relevant local and national codes.

Prevent let air, dust, or other impurities enter in the pipe system during installation.

Insulation pipe shall be used to the gas piping and the liquid piping. Otherwise, the condensate may happen.

7.2 The Procedure of Connecting Pipes

1 Measure the required length of the connecting pipe, then make it by the following way.

- Connect the indoor unit first, then the outdoor unit.

- Bend the tubing in proper way. Do not twist the pipe.

Bend the pipe with thumb



min-radius 100mm/3.94in

Fig.7-1

- Put some refrigerant oil on the surfaces of the flare pipe and the joint nuts then wrench it for 3~4 rounds with hands before fasten the flare nuts.(Refer to chart 16)

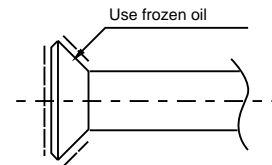

Fig.7-2

- Be sure to use two wrenches simultaneously when you connect or disconnect the pipes.

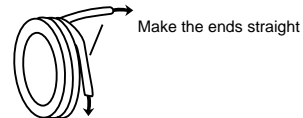

Fig.7-3

- The service valves of the outdoor unit should be completely closed(as original status).Every time to connect,first to loosen nuts, then connect the flare pipes within 5 minutes. If the nuts have been loosened for a long time, dusts and other impurities may enter the pipe system and may cause malfunction.So please expel the air out of the pipe with refrigerant before connection.
- Expel the air(refer to the "8.1")after connecting the refrigerant pipe with the indoor unit and the outdoor unit. Then fasten the nuts at the service valves.
- Bend the connecting pipe of small wall thickness.
 - Cut out a proper concave at the bending part of the insulating pipe.
 - Then expose the pipe(cover it with tapes after bending).
 - To prevent twist of deforming, please bend the pipe at a proper radius.



NOTE

The bending angle should not exceed 90 . °
Bending position is preferably in the middle of the bendable pipe.
Do not bend the pipe more than three times.

Be sure to use the same insulating materials when you buy the brass pipe. (More than 9mm/0.35in thick)

2. Place The Pipe

- Drill a hole in the wall (suitable just for the size of the wall sleeve), then set on the fittings such as the wall sleeve and its cover.
- Bind the connecting pipe and the cables together tightly with binding tapes.
- Pass the bound connecting pipe through the wall sleeve from outside. Make sure of the pipe allocation not to damage the copper tubes.

3 Connect the pipes.

4 Expel the air with a vacuum pump or refrigerant.

5 Open the service valves of the outdoor unit .

6 Check the refrigerant leakage. Check all the joints with the leak detector or soap water.

7 Cover the joints of the connecting pipe with the insulation foam, and bind them well with the tapes to prevent potential leakage.

8. REFRIGERANT PIPE(the unit with the twins function)

8.1 Length and drop height permitted of the refrigerant piping

Note: Reduced length of the branching tube is the 0.5m/1.64ft of the equivalent length of the pipe.

Table.8-1

		Permitted value		Piping
Pipe length	Total pipe length (Actual)	18K+18K	30m/98.42ft	L+L1+L2
		24K+24K/ 30K+30K	50m/164.04ft	
	(farthest from the line pipe branch)	15m/49.21ft		L1,L2
	(farthest from the line pipe branch)	10m/32.8ft		L1-L2
Drop height	Indoor unit-outdoor unit drop height	20m/65.8ft		H1
	Indoor unit to indoor unit drop height	0.5m/1.64ft		H2

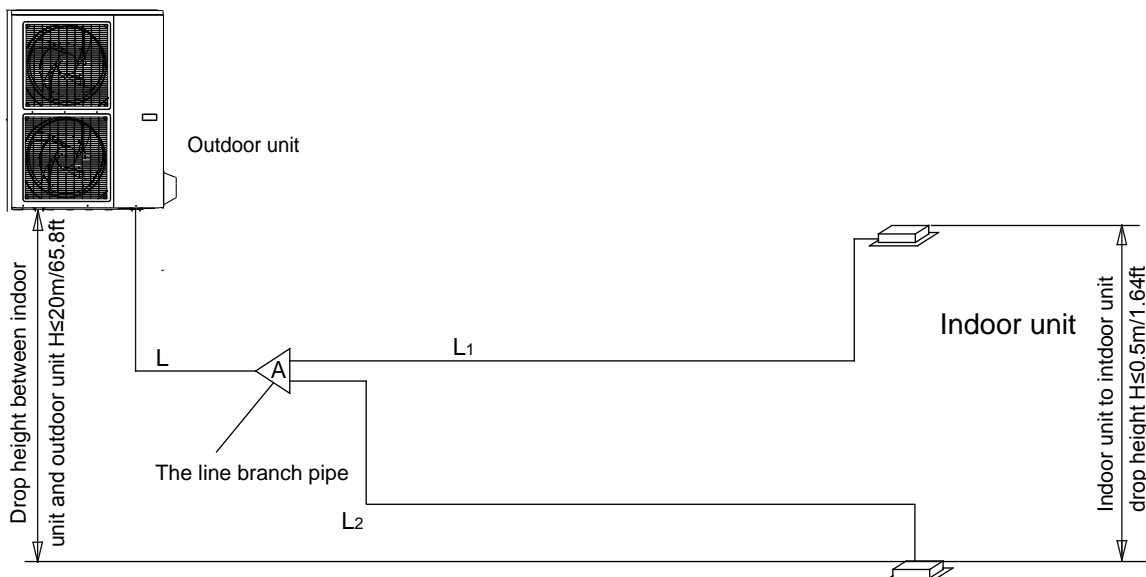

Fig.8-1

Note: All used branch pipe must be produced by Midea, otherwise it causes malfunction. The indoor units should be installed equivalently at the both side of the U type branch pipe.

8.2 Size of joint pipes for indoor unit

Table.8-2 Size of joint pipes for 410A indoor unit

Capacity of indoor unit (A)	Size of main pipe(mm)		
	Gas side	Liquid side	Available branching pipe
18K	Φ12.7/0.5in	Φ6.35/0.25in	CE-FQZHN-01C
24K	Φ15.9/0.626in	Φ9.5/0.375in	CE-FQZHN-01C
30K	Φ15.9/0.626in	Φ9.5/0.375in	CE-FQZHN-01C

8.3 Size of joint pipes for outdoor unit

Base on the following tables, select the diameters of the outdoor unit connective pipes. In case of the main accessory pipe large than the main pipe, take the large one for the selection.

Table.8-3 Size of joint pipes for 410A outdoor unit

Model	the size of main pipe(mm)		
	Gas side	Liquid side	The 1st branching pipe
36K	Φ15.9/0.626in	Φ9.5/0.375in	CE-FQZHN-01C
48K	Φ15.9/0.626in	Φ9.5/0.375in	CE-FQZHN-01C
60K	Φ15.9/0.626in	Φ9.5/0.375in	CE-FQZHN-01C

8.4 Vacuum with vacuum pump

- 1) Use the vacuum pump which vacuum level lower than -0.1MPa and the air discharge capacity above 40L/min.
- 2) The outdoor unit is not necessary to vacuum, don't open the outdoor unit gas and liquid pipe shut-off valves.
- 3) Make sure the vacuum pump could result as -0.1MPa or below after 2 hrs or above operation. If the pump operated 3 hrs or above could not achieve to -0.1MPa or below, please check whether water mix or gas leak inside of the pipe.

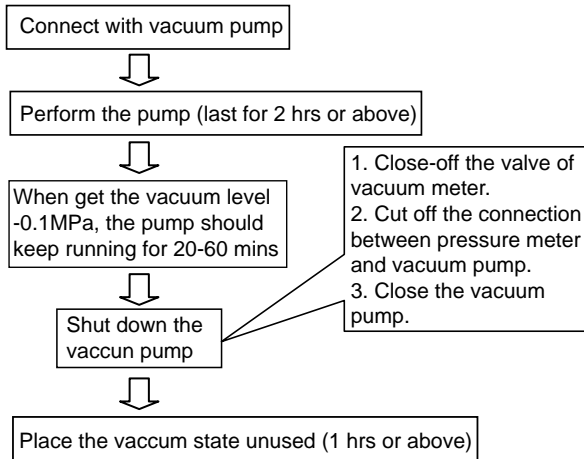

Fig.8-2



CAUTION

- Don't mix up the different refrigerants or abuse the tools and measurements which directly contact with refrigerants.
- Don't adopt refrigerant gas for air vacuuming.
- If vacuum level could not get to -0.1MPa, please check whether resulted by leakage and confirm the leakage site. If no leakage, please operate the vacuum pump again 1 or 2 hrs.

8.5 Refrigerant amount to be added

Calculate the added refrigerant according to the diameter and the length of the liquid side pipe of the outdoor/indoor unit connection. The refrigerant is R410A.

Table.8-4

Pipe size on liquid side	Refrigerant to be Added per meter
Φ6.35/0.25in	0.015kg/0.033lb
Φ9.52/0.375in	0.030kg/0.066lb

- 1) The branching pipe must be installed horizontally, error angle of it should not large than 10°. Otherwise, malfunction will be caused.

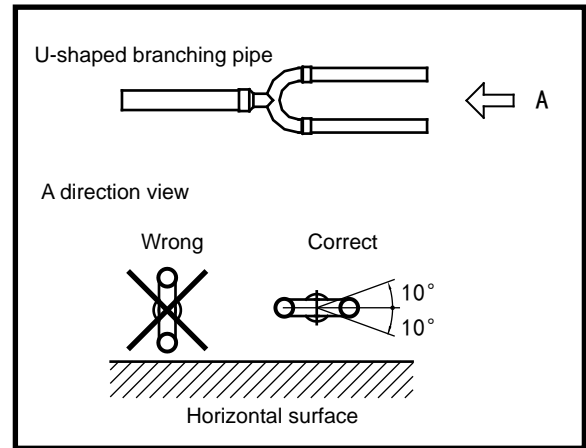

Fig.8-3

9. REFRIGERANT PIPE CONNECTION

9.1 Expel The Air

1 Flaring

- Cut a pipe with a pipe cutter. (Refer to Fig.9-1)

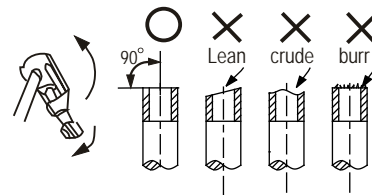

Fig.9-1

- Insert a flare nut into a pipe and flare the pipe.

2 Fasten the nut

- Put the connecting pipes at the proper position, wrench the nuts with hands then fasten it with two wrenches simultaneously. (Refer to Fig.9-2)

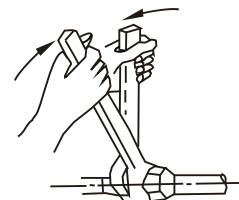

Fig.9-2



CAUTION

Too large torque will harm the bellmouthing and too small will cause leakage. Please determine the torque according to Table 9-1.

Table 9-1

Pipe gauge	Tightening torque	Flare dimensin A		Flare shape
		min (mm)	max	
Ø6.35/0.25in	14.2~17.2 N.m (144~176 kgf.cm)	8.3/0.327in	8.7/0.343in	
Ø9.52/0.375in	32.7~39.9 N.m (333~407 kgf.cm)	12.0/0.472in	12.4/0.488in	
Ø12.7/0.5in	49.5~60.3 N.m (504~616 kgf.cm)	15.4/0.606in	15.8/0.622in	
Ø15.9/0.626in	61.8~75.4 N.m (630~770 kgf.cm)	18.6/0.732in	19.0/0.748in	
Ø19.1/0.725in	97.2~118.6 N.m (990~1210 kgf.cm)	22.9/0.902in	23.3/0.917in	

3 Expel the air with a vacuum pump (Refer to Fig.9-3)

(Please refer to its manual for the way of using manifold valve)

- Loosen and remove the nuts of service valves A and B, and connect the charge hose of the manifold valve with the maintenance terminator of service valve A. (Be sure that service valves A and B are both closed)
- Connect the joint of the charge hose with the vacuum pump.
- Open the Lo-lever of the manifold valve completely.
- Turn on the vacuum pump. At the beginning of pumping, loosen the nut of service valve B a little to check whether the air comes in (the sound of the pump changes, and the indicator of compound meter turns below zero). Then fasten the nut.
- When the pumping has finished, close the Lo-lever of the manifold valve completely and turn off the vacuum pump. When you have pumped for over 15 minutes, please confirm that the indicator of multimeter is on $-1.0 \times 10^{-5} \text{Pa}$ (-76cmHg)
- Loosen and remove the nuts of service valves A and B to open service valve A and B completely, then fasten nuts.
- Disassemble the charge hose of service valve A, and fasten the nut.

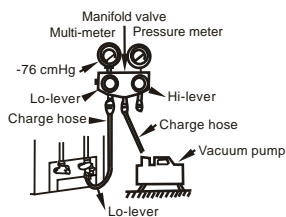

Fig.9-3



CAUTION

Both service valves should be open before test operation. Each air conditioner has two service valves of different sizes. (Refer to Fig.8-4)

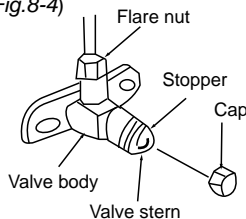

Fig.9-4

9.2 Check the Leakage

Check all the joints with the leak detector or soap water. (Refer Fig.9-5 as a reference illustration) in the chart

- A.....Lo-stop valve
- B.....Hi-stop valve
- C,D...Joints of the connecting pipe to the indoor unit.

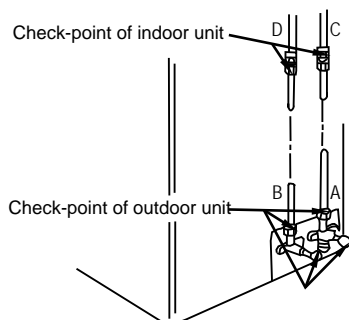

Fig.9-5

9.3 Insulation

- Be sure to completely insulate all the exposed parts of the flare pipes.
- Incomplete insulation may cause condensate.

10. CONNECTIVE DIAGRAM

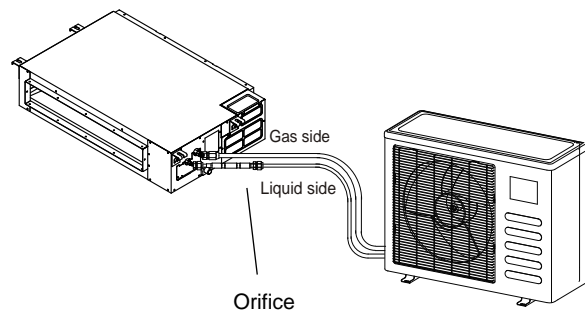

Fig. 10-1



NOTE

For ensuring throttled efficiency, Please mount the Orifice as horizontally as possible; and anti-shock rubber should be wrapped at external of the Orifice for denoise.

Mark the data plate with the Orifice installed.(for some models)

- Please purchase the fittings according to the requirements in the manual strictly.
- Refer the diagram when installing.

NOTE:the orifice should be horizontally installed.

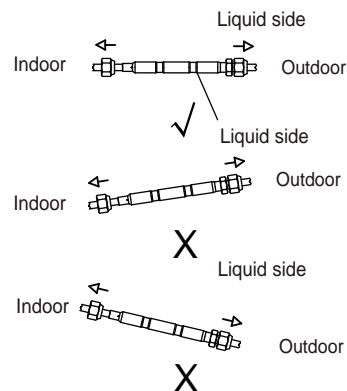

Fig. 10-2

11. CONNECT THE DRAIN PIPE

Install the drainpipe of the indoor unit

- Use a polyethylene tube as the drainpipe (out-dia.29-31mm /1.14-1.22in, in-dia.25mm/0.984in). It could be bought from the local market.
- When extending drainpipe,tighten the connector with water-proof tape to prevent it leakage.
- Please lean the drainpipe down toward outdoor (outlet-side) at a degree of over $1/50$ to avoid water flowing back. And please avoid any bulge.
- Do not drag the drainpipe violently. Meanwhile, one supportpoint should be set every 1~1.5m/3.28~4.92ft to prevent the drainpipe from yielding. Or tie the drainpipe with the connecting pipe to fix it.
- If the outlet of the drainpipe is higher than the body's pump joint, the pipe should be arranged as vertically as possible. And the lift distance must be less than 550mm/21.65in, otherwise the water can not be lifted completely and cause overflow.(Only available for the unit with pump.)
- The end of the drainpipe should be over 50mm/1.969in higher than the ground, and do not immerse it in water. If you discharge the water directly into sewage, be sure to make a U-form aquaseal by bending the pipe up to prevent the smelly gas entering the house through the drain pipe.

The drain pipe installation for the unit with pump.

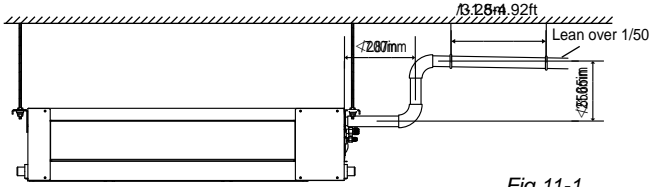

Fig.11-1

The drain pipe installation for the unit without pump.

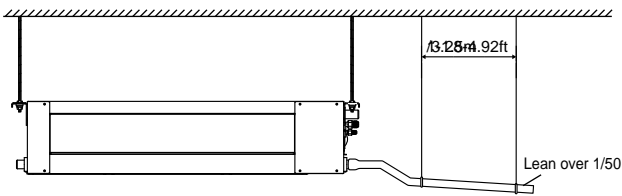
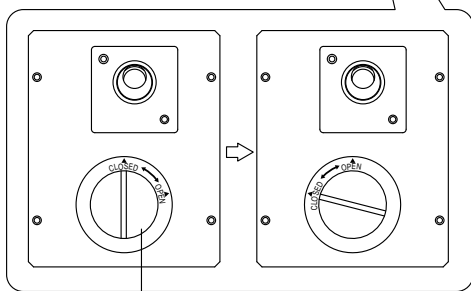
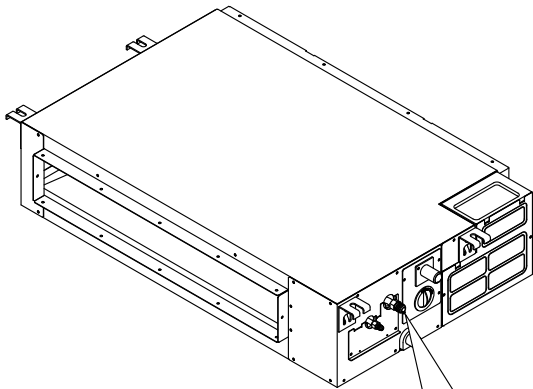

Fig.11-2

■ Drainage test

- Check whether the drainpipe is unhindered.
 - New built house should have this test done before paving the ceiling.
- The unit with pump.

- 1 Remove the test cover, and stow about 2000ml water to the water pan.



Test cap

Fig.11-3

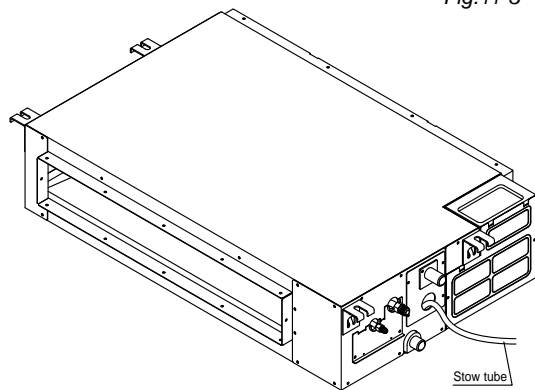
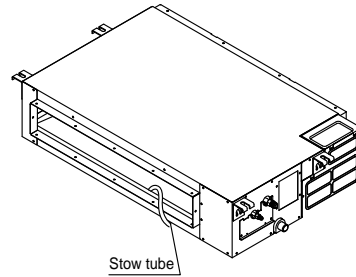

Fig.11-4

- 2 Operate the air conditioner in "COOLING" mode. The sound of the drain pump shall be heard. Check whether the water is discharged well (1 min lag is possible, according to the length of the drain pipe), and check whether the water leaks from the joints.
- 3 Power off the air conditioner and recover the cap.

■ The unit without pump.



Stow tube

Fig.11-5

- Stow 2000ml water to the water pan through the stow tube, check whether the drainpipe is unhindered.

■ Install the drain joint of the outdoor unit (For Heat Pump Models)

Fit the seal into the drain joint, then insert the drain joint into the base pan hole of outdoor, rotate 90° to securely assemble them. Connect the drain joint with an extension drain hose (Locally purchased) to avoid condensate draining off the outdoor unit during the heating mode.

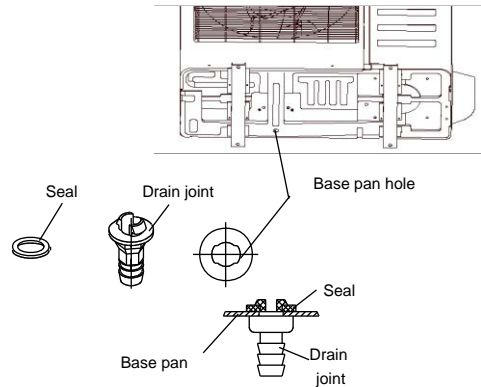

Fig.11-6



NOTE

All the figures in this manual are for explanation purpose only. They may be slightly different from the air conditioner you purchased. The actual unit shall prevail.

12. FRESH AIR DUCT INSTALLATION

Dimension :

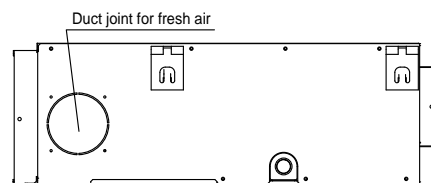

MODEL	
12-24	30-60
<p>Ø90mm/3.54in 80mm/3.15in</p>	<p>Ø125mm/4.92in Ø160mm/6.3in</p>

Fig.12-1

12.1 Motor and drain pump maintenance

(Take rear ventilated as example)

Motor maintain:

1. Take off the ventilated panel.
2. Take off the blower housing.
3. Take off the motor.

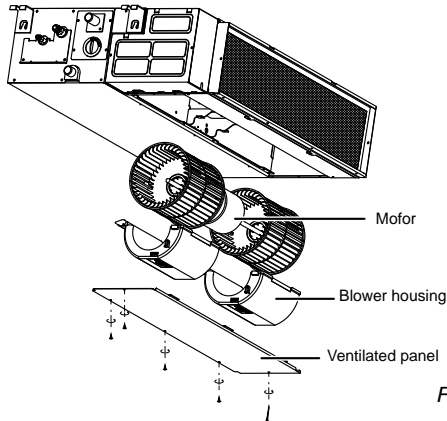

Fig.12-2

Pump maintainance:

1. Screw off four screws from drain pump.
2. Plug off pump power supply and water level switch cable.
3. Take off pump.

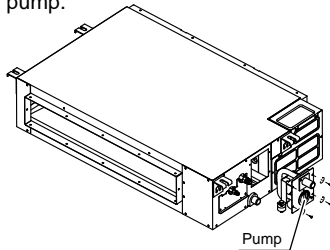

Fig.12-3

13. CONTROL(ONLY FOR INVERTER UNITS)

- The capacity of the system and the network address of the air-conditioner can be set by the switches on the indoor Main Control Board.
- Before setting, turn off the power. After setting, restart the unit.
- Setting is not allowed when the unit is power on.

13.1 Horsepower code setting

The capacity of the indoor unit has been set in the factory according to the below table.

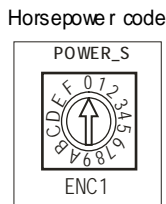

Table 13-1

ENC1	Toggle switch Code	Capacity(kw)
Note: The capacity has been set in the factory , anyone can't adjust it except the qualified person.	4	5.3
	5	5.6
	7	7.1
	8	10.5
	9	14.0
		16.0

13.2 Network address set

Every air-conditioner in network has only one network address to distinguish each other. Address code of air-conditioner in LAN is set by code switches S1 & S2 on the Main Control Board of the indoor unit, and the set range is 0-63.

Table 13-2

Toggle switch set		Network address code
S1	S2	
		00~15
		16~31
		32~47
		48~63

14. WIRING

The appliance shall be installed in accordance with national wiring regulations.

The air conditioner should use separate power supply with rated voltage.

The external power supply to the air conditioner should be grounded, which is linked to the ground wiring of the indoor and outdoor unit.

The wiring work should be done by qualified persons according to wiring diagram.

A circuit breaker and a residual current device (RCD) with above 10mA rating shall be installed in the power circuit according to the national rule.

Be sure to locate the power wiring and the signal wiring well to avoid cross-disturbance.

Do not turn on the power until you have confirmed proper wiring.

The power cord type is H07RN-F.



NOTE

Refer to EMC Directive 2004/108/EC

To prevent flicker impressions during the start of the compressor, following installation conditions do apply.

- 1 The power connection for the air conditioner has to be done at the main power distribution. The distribution has to be of a low impedance, normally the required impedance reaches at a 32 A fusing point.
- 2 No other equipment has to be connected with this power line.
- 3 For detailed installation acceptance please refer to your power supplier, if restrictions do apply for products like washing machines, air conditioners or electrical ovens.
- 4 For power details of the air conditioner refer to the rating nameplate of the product.
- 5 For any question contact your local dealer.

14.1 Connect the cable

- Disassemble the cover.(If there isn't a cover on the outdoor unit, disassemble the screw from the maintenance board, and pull it in the direction of the arrow to remove the protection board.) (Refer to Fig.14-1)
- Connect the cables to the terminals correspondingly.
- Re-install the cover or the protection board.

14.2 The Specification of Power

(Refer to Table14-1~14-8)

14.3 Wiring figure (Refer to Fig.14-2~Fig.14-5)

1.split type outdoor unit

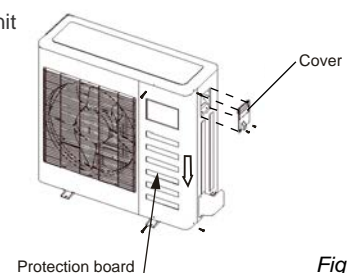

Fig.13-1

2. Centrifugal fan outdoor unit

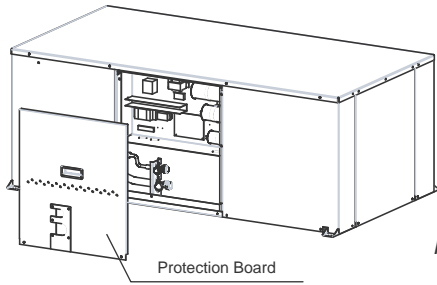

Fig. 14-2



NOTE

All the figures in this manual are for explanation purpose only. They may be slightly different from the air conditioner you purchased (depend on model). The actual unit shall prevail.

15. TEST OPERATION

- 1 The test operation must be carried out after the entire installation.
- 2 Please confirm the following points before the test operation:
 - The indoor unit and outdoor unit are installed properly.
 - Tubing and wiring are correctly completed.
 - The refrigerant pipe system is leakage-checked.
 - The drainage is unimpeded.
 - The heating insulation works well.
 - The ground wiring is connected correctly.
 - The length of the tubing and additional charge amount have been recorded.
 - The power voltage matches rated voltage of the air conditioner.
 - There is no obstacle at the outlet and inlet of the outdoor and indoor units.
 - The gas-side and liquid-side service valves are both completely open.
 - The air conditioner is pre-heated by turning on the power.
- 3 Test operation
 - Set the air conditioner in cooling mode with the remote controller, and check the following points. If there is any malfunction, please resolve it according to the chapter "Troubleshooting" in the "Owner's Manual".
 - 1) The indoor unit
 - a. Whether the buttons on the remote controller works well.
 - b. Whether the air flow louver moves normally.
 - c. Whether the room temperature is adjusted suitable.
 - d. Whether the indicator lights normally.
 - e. Whether the temporary switch on the unit works well.
 - f. Whether the drainage is normal.
 - g. Whether there is abnormal vibration or noise during operation.
 - h. Whether the air conditioner works well in heating mode (heat pump model).
 - 2) The outdoor unit
 - a. Whether there is abnormal vibration and noise during operation.
 - b. Whether the exhaust air, noise, or condensate influence your neighborhood.
 - c. Whether there is any refrigerant leakage during operation.



CAUTION

3 minutes delay is normal when restarting the unit for compressor protection.

The Specification of Power(indoor power supply)

■ Table 14-1

MODEL		18	24	30-36	42-48	60
POWER	PHASE	1Phase	1Phase	1Phase	1Phase	1Phase
	FREQUENCY AND VOLT	208-240V	208-240V	208-240V	208-240V	208-240V
CIRCUIT BREAKER/FUSE(A)		20/16	40/25	50/30	60/45	60/50

■ Table 14-2

MODEL		30-36	42-60	30-36	42-60
POWER	PHASE	3Phase	3Phase	3Phase	3Phase
	FREQUENCY AND VOLT	380-420V	380-420V	208-240V	208-240V
CIRCUIT BREAKER/FUSE(A)		25/20	25/20	40/25	45/35

The Specification of Power(outdoor power supply)

■ Table 14-3

MODEL		12-18	24	30-36	42-48	60
POWER	PHASE	1Phase	1Phase	1Phase	1Phase	1Phase
	FREQUENCY AND VOLT	208-240V	208-240V	208-240V	208-240V	208-240V
CIRCUIT BREAKER/FUSE(A)		20/16	40/30	60/40	70/55	70/60

■ Table 14-4

MODEL		30-36	42-60	30-36	42-60
POWER	PHASE	3Phase	3Phase	3Phase	3Phase
	FREQUENCY AND VOLT	380-420V	380-420V	208-240V	208-240V
CIRCUIT BREAKER/FUSE(A)		25/20	25/20	40/25	45/35

The Specification of Power(independence power supply)

■ Table 14-5

MODEL		18	24	30~36	42~48	60
POWER (indoor)	PHASE	1Phase	1Phase	1Phase	1Phase	1Phase
	FREQUENCY AND VOLT	208-240V	208-240V	208-240V	208-240V	208-240V
CIRCUIT BREAKER/FUSE(A)		20/16	20/16	20/16	20/16	20/16
POWER (outdoor)	PHASE	1Phase	1Phase	1Phase	1Phase	1Phase
	FREQUENCY AND VOLT	208-240V	208-240V	208-240V	208-240V	208-240V
CIRCUIT BREAKER/FUSE(A)		20/16	40/25	50/30	60/45	60/50

■ Table 14-6

MODEL		30~36	42~60	30~36	42~60
POWER (indoor)	PHASE	1Phase	1Phase	1Phase	1Phase
	FREQUENCY AND VOLT	208-240V	208-240V	208-240V	208-240V
CIRCUIT BREAKER/FUSE(A)		20/16	20/16	20/16	20/16
POWER (outdoor)	PHASE	3Phase	3Phase	3Phase	3Phase
	FREQUENCY AND VOLT	380-420V	380-420V	208-240V	208-240V
CIRCUIT BREAKER/FUSE(A)		25/20	25/20	40/25	45/35

The Specification of Power for the invert type air conditioner(independence power supply)

■ Table 14-7

MODEL		18	24	30~36	42~48	60
POWER (indoor)	PHASE	1Phase	1Phase	1Phase	1Phase	1Phase
	FREQUENCY AND VOLT	220-240V	220-240V	220-240V	220-240V	220-240V
CIRCUIT BREAKER/FUSE(A)		15/10	15/10	15/10	15/10	15/10
POWER (outdoor)	PHASE	1Phase	1Phase	1Phase	1Phase	1Phase
	FREQUENCY AND VOLT	208-240V	208-240V	208-240V	208-240V	208-240V
CIRCUIT BREAKER/FUSE(A)		30/20	30/20	40/30	40/35	50/40

■ Table 14-8

MODEL		30~36	42~60	30~36	42~60
POWER (indoor)	PHASE	1Phase	1Phase	1Phase	1Phase
	FREQUENCY AND VOLT	220-240V	220-240V	220-240V	220-240V
CIRCUIT BREAKER/FUSE(A)		15/10	15/10	15/10	15/10
POWER (outdoor)	PHASE	3Phase	3Phase	3Phase	3Phase
	FREQUENCY AND VOLT	380-420V	380-420V	208-240V	208-240V
CIRCUIT BREAKER/FUSE(A)		30/20	30/25	50/40	50/40



CAUTION

The power supply is included in the power supply above mentioned can be applied to the table.
Before obtaining access to terminals, all supply circuits must be disconnected.

■ Wiring figure

■ Fig.14-3

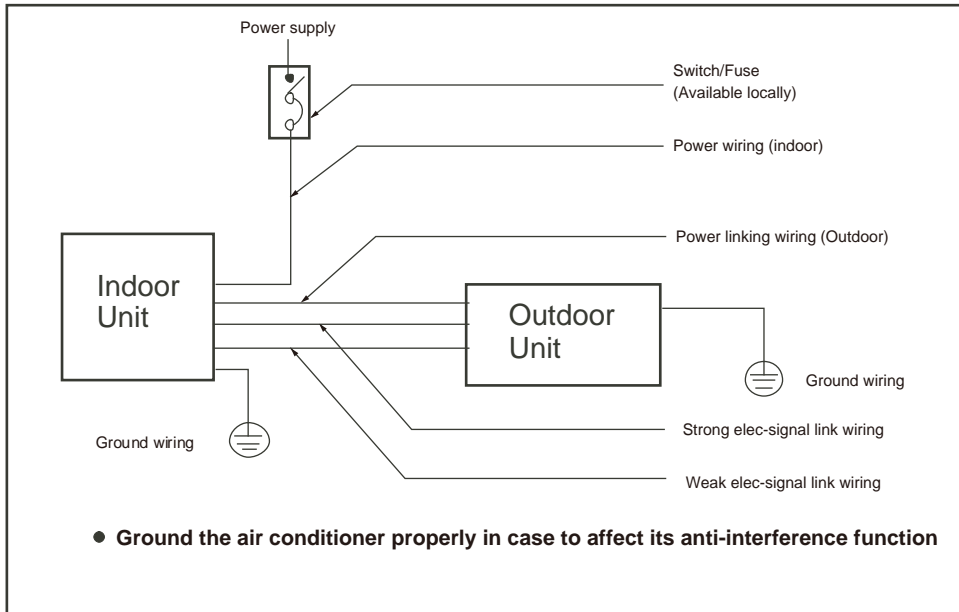

■ Fig.14-4

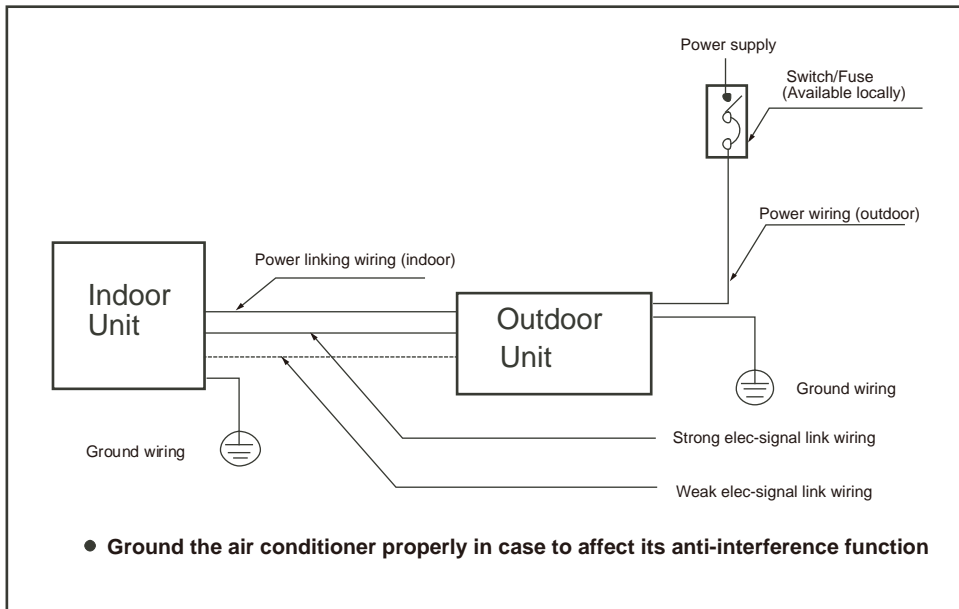

■ Fig.14-5

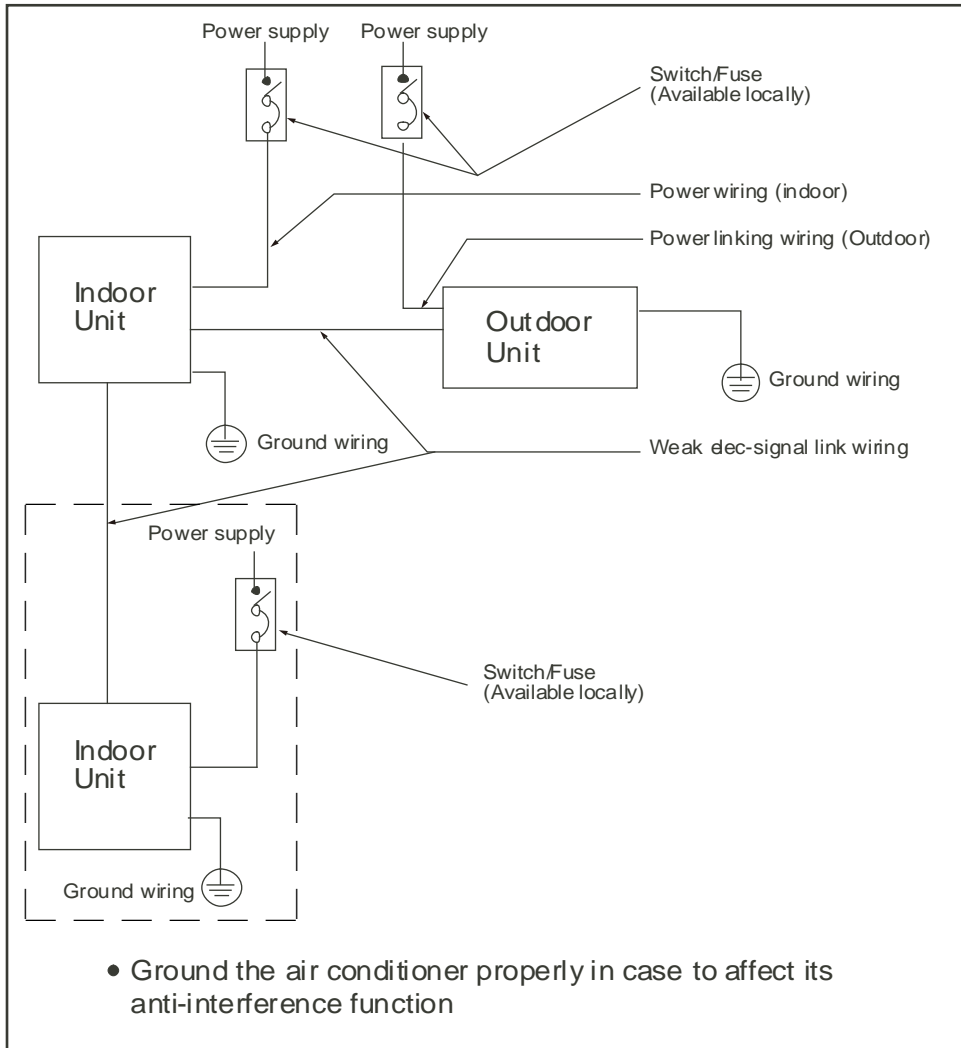

■ Fig.14-6

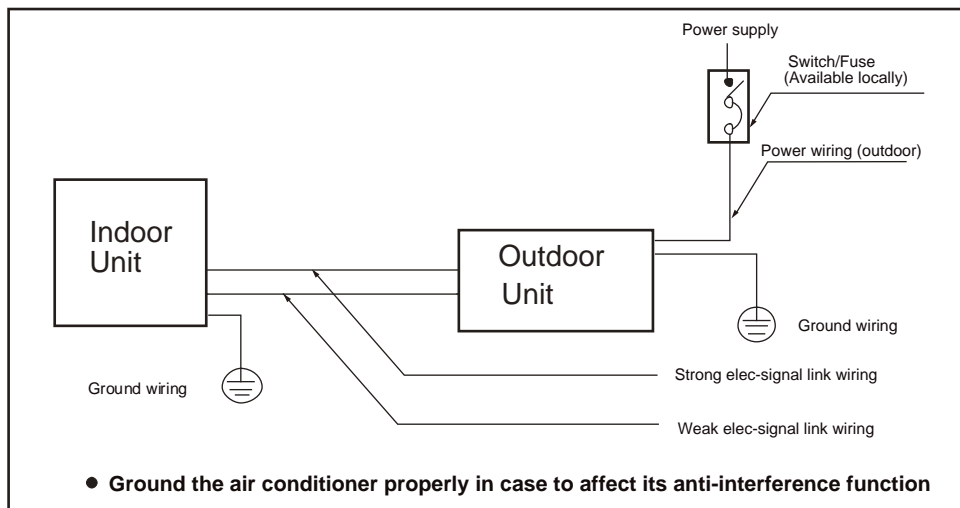

CAUTION

A disconnection device having an air gap contact separation in all active conductors should be incorporated in the fixed wiring according to the National Wiring Regulation.

When wiring, please choose the corresponding chart, or it may cause damage. The signs of the indoor terminal block in the some of following figures may be replaced by L N L1 N1.



The Klimaïre logo is a registered Trademark of Klimaïre Products inc.
Copyright 2016 Klimaïre Products inc.

2190 NW 89 Place, Doral, FL 33172 - USA

Tel: (305)594-4972 Fax (305) 499 4378

www.klimaïre.com sales@klimaïre.com