

EXPANSION VALVE KITS

INSTALLATION INSTRUCTIONS

©2004, 2006, 2009-2010, 2012 Goodman Manufacturing Company, L.P.
5151 San Felipe, Suite 500, Houston, TX 77056
www.goodmanmfg.com -or- www.amana-hac.com
P/N: IO-630F Date: October 2012

ATTENTION INSTALLING PERSONNEL

As a professional installer you have an obligation to know the product better than the customer. This includes all safety precautions and related items.

Prior to actual installation, thoroughly familiarize yourself with this Instruction Manual. Pay special attention to all safety warnings. Often during installation or repair it is possible to place yourself in a position which is more hazardous than when the unit is in operation.

Remember, it is **your** responsibility to install the product safely and to know it well enough to be able to instruct a customer in its safe use.

Safety is a matter of common sense...a matter of thinking before acting. Most dealers have a list of specific good safety practices...follow them.

The precautions listed in this Installation Manual are intended as supplemental to existing practices. However, if there is a direct conflict between existing practices and the content of this manual, the precautions listed here take precedence.

 **WARNING**

HIGH VOLTAGE !

DISCONNECT ALL POWER BEFORE SERVICING.

MULTIPLE POWER SOURCES MAY BE PRESENT. FAILURE TO DO SO MAY CAUSE PROPERTY DAMAGE, PERSONAL INJURY OR DEATH.



SHIPPING INSPECTION

Upon receiving the product, inspect it for damage from shipment. Shipping damage, and subsequent investigation is the responsibility of the carrier. Verify the model number, specifications, electrical characteristics, and accessories are correct prior to installation. The distributor or manufacturer will not accept claims from dealers for transportation damage or installation of incorrectly shipped units.

CODES & REGULATIONS

This product is designed and manufactured to comply with national codes. Installation in accordance with such codes and/or prevailing local codes/regulations is the responsibility of the installer. The manufacturer assumes no responsibility for equipment installed in violation of any codes or regulations.

PRE-INSTALLATION INSTRUCTIONS

IMPORTANT: Piston must be removed from the Flowrator Distributor Assembly for proper Expansion Valve operation.

Piston Removal:

1. Loosen the 13/16 nut **1 TURN ONLY** to allow high pressure tracer gas to escape. No gas indicates a possible leak.
2. After the gas has escaped, remove the nut and discard the black or brass cap.
3. Remove the check piston and seal and discard.
4. Use a tube cutter to remove the spin closure on the suction line.
5. Slide the 13/16 nut into place on the tailpiece supplied with the unit.
6. *For Applications requiring a Field-Installed Access Fitting (see Figure 1 on following page).*
 - a. Braze the appropriate equalizer stub to suction line field connection on coil. Slide grommet and insulation back before brazing. Plan fitting position for convenient connection to 1/4" flare nut on equalizer tube.
 - b. Braze suction line tubing (line set) to the stub.
 - c. Reinstall the suction line grommet and insulation.

For Applications NOT Requiring a Field-Installed Access Fitting (see Figure 2 on following page).

- a. Braze the suction line field connection on coil. Slide grommet and insulation back before brazing and feed the valve equalizer line through the grommet.
- b. Reinstall the suction line grommet and feed the equalizer line through the opening.

INSTALLATION INSTRUCTIONS

1. Connect expansion valve outlet with new seal supplied with kit to flowrator body. Make sure the seal is in place.

NOTE DIRECTION OF FLOW (Fluid is flowing towards the evaporator coil).



2. Slide the 13/16 nut into position. Braze tailpiece to the liquid tube (line set).
 3. AFTER THE TAILPIECE HAS COOLED, position the seal and hand tighten the nut.
 4. Torque the 13/16 nut to 10-30 ft/lb. or tighten 1/6 turn.
 5. Connect equalizer tube with 1/4 flare nut to suction line fitting on the equalizer stub (as shown in Figure 1) or coil suction manifold (as shown in Figure 2) and torque to 12-14 ft/lb.
 6. Secure expansion valve bulb to suction line with banding straps provided at the 10 o'clock or 2 o'clock position. If the suction line is a combination of copper and aluminum tubes, neither the copper strap nor the bulb should be touching any of the aluminum tubes. The copper strap should attach the bulb only to the copper section of the suction tube.
- IMPORTANT:** Insulate the bulb and adjacent area.
7. Check for leaks.
 8. Enclose expansion valve with the supplied expansion valve blanket.
 9. During the superheat adjustment on the TXV, the torque applied on the nut cannot exceed 25 in-lbs

FIGURE 1: Applications Requiring A Field Installed Access Fitting

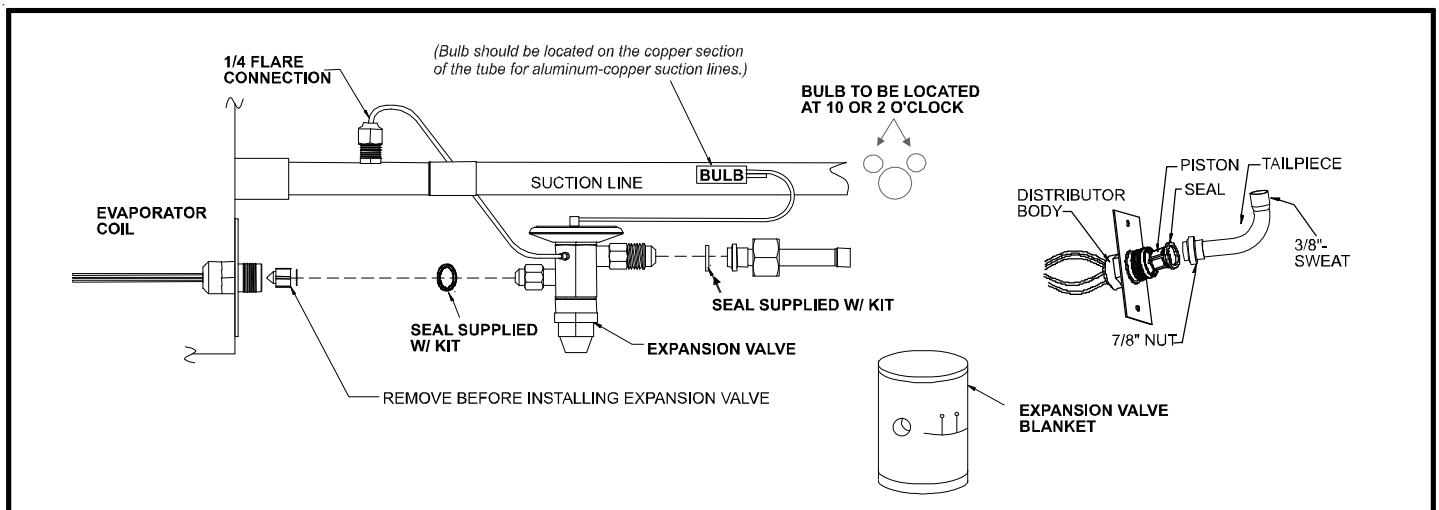
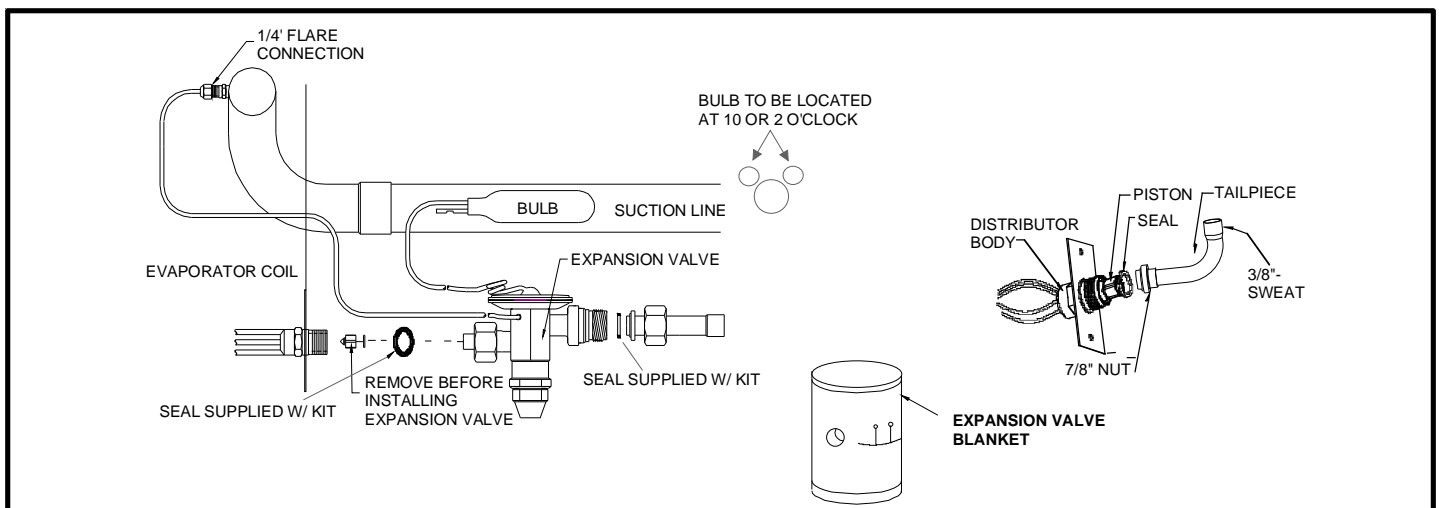

FIGURE 2: Applications NOT Requiring A Field Installed Access Fitting



EXPANSION VALVE TROUBLESHOOTING:

Before replacing an expansion valve, check the following items:

1. **Bulb location:** Must be tightly secured to the suction line upstream of the equalizer connection.
2. **Insulation:** Bulb must be properly insulated with the material supplied in the TXV kit.
3. **Equalizer:** Must be connected to the 1/4" SAE connection on the suction line.
4. **Charge:** Ensure the system is properly charged. There **MUST** be a minimum of 10°F Sub-Cooled liquid at the valve inlet.

If the system appears to be "starving" (low suction pressure but insufficient cooling):

1. Check the Superheat (SH) at the evaporator outlet. If SH is between 5°F - 12°F, the TXV is controlling properly.
 - Verify that there is proper airflow to the evaporator (fan is operating and filter is unrestricted).
2. If SH is above 12°F, the setting of the TXV may be too high.
 - Adjust the SH by turning counter-clockwise to decrease SH.
 - Wait 20 minutes for the system to balance and adjust again, as required.
 - If adjusting the valve has no effect on the SH, the valve may be stuck because of dirt or debris or it may have lost the Power Element charge.
 - i. After properly reclaiming the refrigerant, remove the TXV and check for dirt and debris. Clean, if possible, or replace the TXV and filter/drier.

If the system appears to be "flooding" (compressor frosting or moisture condensing at the suction connection):

1. Check the SH at the evaporator outlet. If SH is between 5°F - 12°F, the TXV is controlling properly.
2. If SH is less than 5°F, the SH adjustment may be too low.
 - a. Adjust the SH by turning the adjustment stem clockwise to increase the SH.
 - b. Wait 20 minutes for the system to balance and adjust again as required.
 - c. If adjusting the valve has no effect on the SH, the valve may be stuck open because of dirt or debris or moisture in the refrigerant.
 - i. After properly reclaiming the refrigerant, remove the TXV and check for dirt and debris. Clean, if possible, or replace the TXV and filter/drier. Add a moisture indicator to allow checking of moisture if this is believed to be a probable cause.

Troubleshooting Expansion Valves

Superheat Too Low -- TXV Feeds Too Much

Problem	Symptoms	Causes	Corrective Action
Valve Feeds Too Much	1) Liquid Slugging 2) Low Superheat 3) Suction Pressure Normal or High	Oversized Valve	Replace with correct size valve
		Incorrect Superheat Setting	Adjust the superheat to correct setting
		Moisture	Replace the filter driers; evacuate the system and replace the refrigerant
		Dirt or Foreign Material	Clean out the material or replace the valve
		Incorrect Charge Selection	Select proper charge based on refrigerant type
		Incorrect Bulb Location	Relocate the bulb to proper location
		Incorrect Equalizer Location	Relocate the equalizer to proper location
		Plugged Equalizer (Balanced Port Valve)	Remove any restriction in the equalizer tube

Superheat Is Too High -- TXV Doesn't Feed or Doesn't Feed Enough

Problem	Symptoms	Causes	Corrective Action
Valve Doesn't Feed or Doesn't Feed Enough	1) Evaporator Temperature Too High 2) High Superheat 3) Low Suction Pressure	Short of Refrigerant	Add correct amount of refrigerant
		High Superheat	Change superheat setting
		Flash Gas In Liquid Line	Remove source of restriction
		Low or Lost Bulb Charge	Replace power element or valve
		Moisture	Replace driers or evacuate the system and replace refrigerant
		Plugged Equalizer (Conventional Valve)	Remove restriction in equalizer tube
		Insufficient Pressure Drop or Valve Too Small	Replace existing valve with properly sized valve
		Dirt or Foreign Material	Clean out material or replace valve
		Incorrect Charge Selection	Select correct charge
		Incorrect Bulb Location	Move bulb to correct location
		Incorrect Equalizer Location	Move equalizer to correct location
		Charge Migration (MOP Only, Vapor Charges)	Move valve to a warmer location or apply heat tape to powerhead
		Wax	Use charcoal drier
		Wrong equalizer type valve	Use extremely equalized valve
		Rod Leakage (Balanced Port Valve)	Replace valve
		Heat Damaged Powerhead	Replace powerhead or valve

Superheat Is Erratic Or Hunts

Problem	Symptoms	Causes	Corrective Action
Erratic pressures and poor performance	TXV alternately opens and closes, causing large fluctuations in superheat.	Bulb Location Incorrect	Reposition Bulb
		Valve Too Large	Replace with correctly sized valve
		Incorrect Superheat Setting	Adjust superheat to correct setting

No Superheat At Start Up Only

Problem	Symptoms	Causes	Corrective Action
Valve Feeds Too Much At Start Up	1) Liquid Slugging 2) Zero Superheat 3) Suction Pressure Too High	Refrigerant Drainage/Migration	Use pump down control; install trap at the top of the evaporator
		Compressor or Suction Line in a Cold Location	Install crankcase heater; install suction solenoid
		Partially Restricted or Plugged External Equalizer (Balanced Port Valve)	Remove restriction in equalizer tube

Superheat Appears Normal - System Performs Poorly

Problem	Symptoms	Causes	Corrective Action
Valve Doesn't Feed Properly	1) Poor System Performance 2) Low or Normal Superheat 3) Low Suction Pressure	Unequal Circuit Loading	Make modification to balance load
		Low Load	Correct conditions causing low load
		Mismatched Coil/Compressor	Correct match
		Incorrect Distributor	Install correct distributor
		Evaporator Oil-Logged	Increase gas velocity through coil