



NEW PRODUCT ANNOUNCEMENT

NEW! NR662-OD



BTU Input Range: 15,000 - 140,000
 Max Flow Rate: 6.6 gpm
 Dimensions: 20.5" x 13.8" x 6.7"
 Exhaust Type: OD
 Warranty: 12 years Heat Exchanger
 5 years Parts
 1 year Pre-Approved Reasonable Labor

- BTU Input Range 15,000 - 140,000
- Flow Rate 0.5 - 6.6 gpm
- **New scale detection software**
- 3/4" Gas Line Connection
- New Display Window
- Compact Design
- Tech Data Sheet Included

**Available:
Jan 1st, 2014**

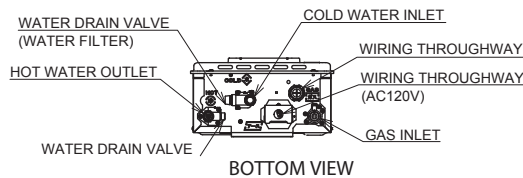
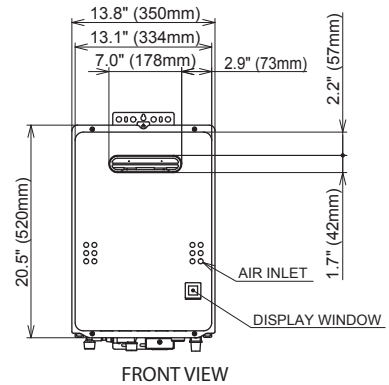
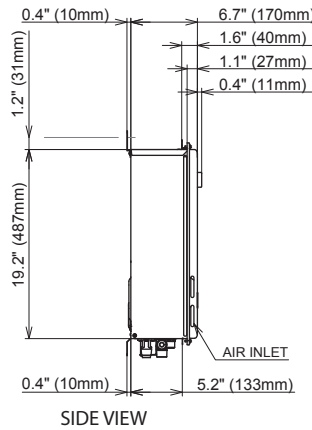

HEIGHT OF EACH FITTING FROM BOTTOM OF CASE

	NR662-OD
HOT WATER OUTLET	1.8" (45mm)
COLD WATER INLET	1.9" (49mm)
GAS INLET	2.0" (50mm)

ACCESSORIES:

- Isolator Valves (#IK-WV-200-1-xx-LF)
- Pipe Cover (#PC-1S)
- Recess Box (#RB-510)